



# Electrical installation handbook

Volume 1

## Protection and control devices



4<sup>th</sup> edition  
March 2006

First edition 2003  
Second edition 2004  
Third edition 2005  
Fourth edition 2006

*Published by ABB SACE  
via Baioni, 35 - 24123 Bergamo (Italy)*

All rights reserved

---

# Index

<b>Introduction</b> .....	2
<b>1 Standards</b> .....	3
1.1 General aspects .....	3
1.2 IEC Standards for electrical installation .....	15
<b>2 Protection and control devices</b> .....	22
2.1 Circuit-breaker nameplates .....	25
2.2 Main definitions .....	28
2.3 Types of releases .....	28
<b>3 General characteristics</b> .....	40
3.1 Electrical characteristics of circuit breakers .....	51
3.2 Trip curves .....	130
3.3 Limitation curves .....	169
3.4 Specific let-through energy curves .....	204
3.5 Temperature derating .....	225
3.6 Altitude derating .....	226
3.7 Electrical characteristics of switch disconnectors .....	232
<b>4 Protection coordination</b> .....	241
4.1 Protection coordination .....	266
4.2 Discrimination tables .....	270
4.3 Back-up tables .....	274
4.4 Coordination tables between circuit breakers and switch disconnectors .....	285
<b>5 Special applications</b> .....	302
5.1 Direct current networks .....	302
5.2 Networks at particular frequencies; 400 Hz and 16 2/3 Hz .....	314
5.3 1000 Vdc and 1000 Vac networks .....	314
5.4 Automatic Transfer Switches .....	314
<b>6 Switchboards</b> .....	323
6.1 Electrical switchboards .....	331
6.2 MNS switchboards .....	332
6.3 ArTu distribution switchboards .....	332
<b>Annex A: Protection against short-circuit effects inside     low-voltage switchboards</b> .....	335
<b>Annex B: Temperature rise evaluation     according to IEC 60890</b> .....	344
<b>Annex C: Application examples:     Advanced protection functions     with PR123/P and PR333/P releases</b> .....	360

---

## Introduction

### Scope and objectives

The scope of this electrical installation handbook is to provide the designer and user of electrical plants with a quick reference, immediate-use working tool. This is not intended to be a theoretical document, nor a technical catalogue, but, in addition to the latter, aims to be of help in the correct definition of equipment, in numerous practical installation situations.

The dimensioning of an electrical plant requires knowledge of different factors relating to, for example, installation utilities, the electrical conductors and other components; this knowledge leads the design engineer to consult numerous documents and technical catalogues. This electrical installation handbook, however, aims to supply, in a single document, tables for the quick definition of the main parameters of the components of an electrical plant and for the selection of the protection devices for a wide range of installations. Some application examples are included to aid comprehension of the selection tables.

### Electrical installation handbook users

The electrical installation handbook is a tool which is suitable for all those who are interested in electrical plants: useful for installers and maintenance technicians through brief yet important electrotechnical references, and for sales engineers through quick reference selection tables.

### Validity of the electrical installation handbook

Some tables show approximate values due to the generalization of the selection process, for example those regarding the constructional characteristics of electrical machinery. In every case, where possible, correction factors are given for actual conditions which may differ from the assumed ones. The tables are always drawn up conservatively, in favour of safety; for more accurate calculations, the use of DOCWin software is recommended for the dimensioning of electrical installations.

---

## 1 Standards

### 1.1 General aspects

In each technical field, and in particular in the electrical sector, a condition sufficient (even if not necessary) for the realization of plants according to the **“status of the art”** and a requirement essential to properly meet the demands of customers and of the community, is the respect of all the relevant laws and technical standards.

Therefore, a precise knowledge of the standards is the fundamental premise for a correct approach to the problems of the electrical plants which shall be designed in order to guarantee that **“acceptable safety level”** which is never absolute.

#### *Juridical Standards*

These are all the standards from which derive rules of behavior for the juridical persons who are under the sovereignty of that State.

#### *Technical Standards*

These standards are the whole of the prescriptions on the basis of which machines, apparatus, materials and the installations should be designed, manufactured and tested so that efficiency and function safety are ensured.

The technical standards, published by national and international bodies, are circumstantially drawn up and can have legal force when this is attributed by a legislative measure.

	Application fields		
	Electrotechnics and Electronics	Telecommunications	Mechanics, Ergonomics and Safety
International Body	IEC	ITU	ISO
European Body	CENELEC	ETSI	CEN

This technical collection takes into consideration only the bodies dealing with electrical and electronic technologies.

### IEC International Electrotechnical Commission

The *International Electrotechnical Commission* (IEC) was officially founded in 1906, with the aim of securing the international co-operation as regards standardization and certification in electrical and electronic technologies. This association is formed by the International Committees of over 40 countries all over the world.

The IEC publishes international standards, technical guides and reports which are the bases or, in any case, a reference of utmost importance for any national and European standardization activity.

IEC Standards are generally issued in two languages: English and French.

In 1991 the IEC has ratified co-operation agreements with CENELEC (European standardization body), for a common planning of new standardization activities and for parallel voting on standard drafts.

## 1 Standards

### CENELEC European Committee for Electrotechnical Standardization

The *European Committee for Electrotechnical Standardization* (CENELEC) was set up in 1973. Presently it comprises 29 countries (Austria, Belgium, Cyprus, Czech Republic, Denmark, Estonia, Finland, France, Germany, Greece, Hungary, Iceland, Ireland, Italy, Latvia, Lithuania, Luxembourg, Malta, Netherlands, Norway, Portugal, Poland, Romania, Slovakia, Slovenia, Spain, Sweden, Switzerland, United Kingdom) and cooperates with 8 affiliates (Albania, Bosnia and Herzegovina, Bulgaria, Croatia, Former Yugoslav Republic of Macedonia, Serbia and Montenegro, Turkey, Ukraine) which have first maintained the national documents side by side with the CENELEC ones and then replaced them with the Harmonized Documents (HD).

There is a difference between EN Standards and Harmonization Documents (HD): while the first ones have to be accepted at any level and without additions or modifications in the different countries, the second ones can be amended to meet particular national requirements.

EN Standards are generally issued in three languages: English, French and German.

From 1991 CENELEC cooperates with the IEC to accelerate the standards preparation process of International Standards.

CENELEC deals with specific subjects, for which standardization is urgently required.

When the study of a specific subject has already been started by the IEC, the European standardization body (CENELEC) can decide to accept or, whenever necessary, to amend the works already approved by the International standardization body.

### EC DIRECTIVES FOR ELECTRICAL EQUIPMENT

Among its institutional roles, the European Community has the task of promulgating directives which must be adopted by the different member states and then transposed into national law.

Once adopted, these directives come into juridical force and become a reference for manufacturers, installers, and dealers who must fulfill the duties prescribed by law.

Directives are based on the following principles:

- harmonization is limited to essential requirements;
- only the products which comply with the essential requirements specified by the directives can be marketed and put into service;
- the harmonized standards, whose reference numbers are published in the Official Journal of the European Communities and which are transposed into the national standards, are considered in compliance with the essential requirements;
- the applicability of the harmonized standards or of other technical specifications is facultative and manufacturers are free to choose other technical solutions which ensure compliance with the essential requirements;
- a manufacturer can choose among the different conformity evaluation procedure provided by the applicable directive.

The scope of each directive is to make manufacturers take all the necessary steps and measures so that the product does not affect the safety and health of persons, animals and property.

## 1 Standards

### “Low Voltage” Directive 73/23/CEE – 93/68/CEE

The Low Voltage Directive refers to any electrical equipment designed for use at a rated voltage from 50 to 1000 V for alternating current and from 75 to 1500 V for direct current.

In particular, it is applicable to any apparatus used for production, conversion, transmission, distribution and use of electrical power, such as machines, transformers, devices, measuring instruments, protection devices and wiring materials.

The following categories are outside the scope of this Directive:

- electrical equipment for use in an explosive atmosphere;
- electrical equipment for radiology and medical purposes;
- electrical parts for goods and passenger lifts;
- electrical energy meters;
- plugs and socket outlets for domestic use;
- electric fence controllers;
- radio-electrical interference;
- specialized electrical equipment, for use on ships, aircraft or railways, which complies with the safety provisions drawn up by international bodies in which the Member States participate.

### Directive EMC 89/336/EEC (“Electromagnetic Compatibility”)

The Directive on electromagnetic compatibility regards all the electrical and electronic apparatus as well as systems and installations containing electrical and/or electronic components. In particular, the apparatus covered by this Directive are divided into the following categories according to their characteristics:

- domestic radio and TV receivers;
- industrial manufacturing equipment;
- mobile radio equipment;
- mobile radio and commercial radio telephone equipment;
- medical and scientific apparatus;
- information technology equipment (ITE);
- domestic appliances and household electronic equipment;
- aeronautical and marine radio apparatus;
- educational electronic equipment;
- telecommunications networks and apparatus;
- radio and television broadcast transmitters;
- lights and fluorescent lamps.

The apparatus shall be so constructed that:

- a) the electromagnetic disturbance it generates does not exceed a level allowing radio and telecommunications equipment and other apparatus to operate as intended;
- b) the apparatus has an adequate level of intrinsic immunity to electromagnetic disturbance to enable it to operate as intended.

An apparatus is declared in conformity to the provisions at points a) and b) when the apparatus complies with the harmonized standards relevant to its product family or, in case there aren't any, with the general standards.

# 1 Standards

## CE conformity marking

The CE conformity marking shall indicate conformity to all the obligations imposed on the manufacturer, as regards his products, by virtue of the European Community directives providing for the affixing of the CE marking.



When the CE marking is affixed on a product, it represents a declaration of the manufacturer or of his authorized representative that the product in question conforms to all the applicable provisions including the conformity assessment procedures. This prevents the Member States from limiting the marketing and putting into service of products bearing the CE marking, unless this measure is justified by the proved non-conformity of the product.

Flow diagram for the conformity assessment procedures established by the Directive 73/23/EEC on electrical equipment designed for use within particular voltage range:

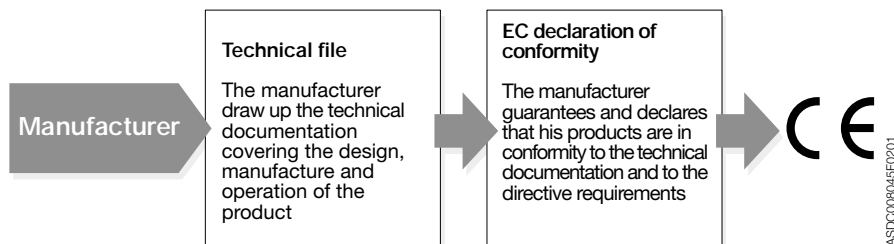

## Naval type approval

The environmental conditions which characterize the use of circuit breakers for on-board installations can be different from the service conditions in standard industrial environments; as a matter of fact, marine applications can require installation under particular conditions, such as:

- environments characterized by high temperature and humidity, including salt-mist atmosphere (damp-heat, salt-mist environment);
- on board environments (engine room) where the apparatus operate in the presence of vibrations characterized by considerable amplitude and duration.

In order to ensure the proper function in such environments, the shipping registers require that the apparatus has to be tested according to specific type approval tests, the most significant of which are vibration, dynamic inclination, humidity and dry-heat tests.

# 1 Standards

ABB SACE circuit-breakers (Isomax-Tmax-Emax) are approved by the following shipping registers:

• <b>RINA</b>	Registro Italiano Navale	Italian shipping register
• <b>DNV</b>	Det Norske Veritas	Norwegian shipping register
• <b>BV</b>	Bureau Veritas	French shipping register
• <b>GL</b>	Germanischer Lloyd	German shipping register
• <b>LRS</b>	Lloyd's Register of Shipping	British shipping register
• <b>ABS</b>	American Bureau of Shipping	American shipping register









It is always advisable to ask ABB SACE as regards the typologies and the performances of the certified circuit-breakers or to consult the section certificates in the website <http://bol.it.abb.com>.

## Marks of conformity to the relevant national and international Standards









The international and national marks of conformity are reported in the following table, for information only:

COUNTRY	Symbol	Mark designation	Applicability/Organization
EUROPE		-	Mark of compliance with the harmonized European standards listed in the ENEC Agreement.
AUSTRALIA		AS Mark	Electrical and non-electrical products. It guarantees compliance with SAA (Standard Association of Australia).
AUSTRALIA		S.A.A. Mark	Standards Association of Australia (S.A.A.). The Electricity Authority of New South Wales Sydney Australia
AUSTRIA		Austrian Test Mark	Installation equipment and materials









## 1 Standards

COUNTRY	Symbol	Mark designation	Applicability/Organization
AUSTRIA		ÖVE Identification Thread	Cables
BELGIUM		CEBEC Mark	Installation materials and electrical appliances
BELGIUM		CEBEC Mark	Conduits and ducts, conductors and flexible cords
BELGIUM		Certification of Conformity	Installation material and electrical appliances (in case there are no equivalent national standards or criteria)
CANADA		CSA Mark	Electrical and non-electrical products. This mark guarantees compliance with CSA (Canadian Standard Association)
CHINA		CCEE Mark	Great Wall Mark Commission for Certification of Electrical Equipment
Czech Republic		EZU' Mark	Electrotechnical Testing Institute
Slovakia Republic		EVPU' Mark	Electrotechnical Research and Design Institute

## 1 Standards

COUNTRY	Symbol	Mark designation	Applicability/Organization
CROATIA		KONKAR	Electrical Engineering Institute
DENMARK		DEMKO Approval Mark	Low voltage materials. This mark guarantees the compliance of the product with the requirements (safety) of the "Heavy Current Regulations"
FINLAND		Safety Mark of the Elektriska Inspektoratet	Low voltage material. This mark guarantees the compliance of the product with the requirements (safety) of the "Heavy Current Regulations"
FRANCE		ESC Mark	Household appliances
FRANCE		NF Mark	Conductors and cables – Conduits and ducting – Installation materials
FRANCE		NF Identification Thread	Cables
FRANCE		NF Mark	Portable motor-operated tools
FRANCE		NF Mark	Household appliances

## 1 Standards







COUNTRY	Symbol	Mark designation	Applicability/Organization
GERMANY		VDE Mark	For appliances and technical equipment, installation accessories such as plugs, sockets, fuses, wires and cables, as well as other components (capacitors, earthing systems, lamp holders and electronic devices)
GERMANY		VDE Identification Thread	Cables and cords
GERMANY		VDE Cable Mark	For cables, insulated cords, installation conduits and ducts
GERMANY		VDE-GS Mark for technical equipment	Safety mark for technical equipment to be affixed after the product has been tested and certified by the VDE Test Laboratory in Offenbach; the conformity mark is the mark VDE, which is granted both to be used alone as well as in combination with the mark GS
HUNGARY		MEEI	Hungarian Institute for Testing and Certification of Electrical Equipment
JAPAN		JIS Mark	Mark which guarantees compliance with the relevant Japanese Industrial Standard(s).
IRELAND		IIRS Mark	Electrical equipment
IRELAND		IIRS Mark	Electrical equipment

## 1 Standards



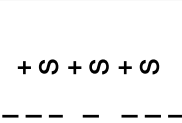





COUNTRY	Symbol	Mark designation	Applicability/Organization
ITALY		IMQ Mark	Mark to be affixed on electrical material for non-skilled users; it certifies compliance with the European Standard(s).
NORWAY		Norwegian Approval Mark	Mandatory safety approval for low voltage material and equipment
NETHERLANDS		KEMA-KEUR	General for all equipment
POLAND		KWE	Electrical products
RUSSIA		Certification of Conformity	Electrical and non-electrical products. It guarantees compliance with national standard (Gosstandard of Russia)
SINGAPORE		SISR	Electrical and non-electrical products
SLOVENIA		SIQ	Slovenian Institute of Quality and Metrology
SPAIN		AEE	Electrical products. The mark is under the control of the Asociación Electrotécnica Española (Spanish Electrotechnical Association)



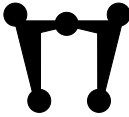

## 1 Standards

COUNTRY	Symbol	Mark designation	Applicability/Organization
SPAIN		AENOR	Asociación Española de Normalización y Certificación. (Spanish Standardization and Certification Association)
SWEDEN		SEMKO Mark	Mandatory safety approval for low voltage material and equipment.
SWITZERLAND		Safety Mark	Swiss low voltage material subject to mandatory approval (safety).
SWITZERLAND		–	Cables subject to mandatory approval
SWITZERLAND		SEV Safety Mark	Low voltage material subject to mandatory approval
UNITED KINGDOM		ASTA Mark	Mark which guarantees compliance with the relevant "British Standards"
UNITED KINGDOM		BASEC Mark	Mark which guarantees compliance with the "British Standards" for conductors, cables and ancillary products.
UNITED KINGDOM		BASEC Identification Thread	Cables

## 1 Standards

COUNTRY	Symbol	Mark designation	Applicability/Organization
UNITED KINGDOM		BEAB Safety Mark	Compliance with the "British Standards" for household appliances
UNITED KINGDOM		BSI Safety Mark	Compliance with the "British Standards"
UNITED KINGDOM		BEAB Kitemark	Compliance with the relevant "British Standards" regarding safety and performances
U.S.A.		UNDERWRITERS LABORATORIES Mark	Electrical and non-electrical products
U.S.A.		UNDERWRITERS LABORATORIES Mark	Electrical and non-electrical products
U.S.A.		UL Recognition	Electrical and non-electrical products
CEN		CEN Mark	Mark issued by the European Committee for Standardization (CEN); it guarantees compliance with the European Standards.
CENELEC		Mark	Cables

## 1 Standards

COUNTRY	Symbol	Mark designation	Applicability/Organization
CENELEC		Harmonization Mark	Certification mark providing assurance that the harmonized cable complies with the relevant harmonized CENELEC Standards – identification thread
EC		Ex EUROPEA Mark	Mark assuring the compliance with the relevant European Standards of the products to be used in environments with explosion hazards
CEEel		CEEel Mark	Mark which is applicable to some household appliances (shavers, electric clocks, etc).

### EC - Declaration of Conformity

The EC Declaration of Conformity is the statement of the manufacturer, who declares under his own responsibility that all the equipment, procedures or services refer and comply with specific standards (directives) or other normative documents.

The EC Declaration of Conformity should contain the following information:

- name and address of the manufacturer or by its European representative;
- description of the product;
- reference to the harmonized standards and directives involved;
- any reference to the technical specifications of conformity;
- the two last digits of the year of affixing of the CE marking;
- identification of the signer.

A copy of the EC Declaration of Conformity shall be kept by the manufacturer or by his representative together with the technical documentation.

## 1 Standards

### 1.2 IEC Standards for electrical installation

STANDARD	YEAR	TITLE
IEC 60027-1	1992	Letter symbols to be used in electrical technology - Part 1: General
IEC 60034-1	2004	Rotating electrical machines - Part 1: Rating and performance
IEC 60617-DB-12M	2001	Graphical symbols for diagrams - 12-month subscription to online database comprising parts 2 to 11 of IEC 60617
IEC 61082-1	1991	Preparation of documents used in electrotechnology - Part 1: General requirements
IEC 61082-2	1993	Preparation of documents used in electrotechnology - Part 2: Function-oriented diagrams
IEC 61082-3	1993	Preparation of documents used in electrotechnology - Part 3: Connection diagrams, tables and lists
IEC 61082-4	1996	Preparation of documents used in electrotechnology - Part 4: Location and installation documents
IEC 60038	2002	IEC standard voltages
IEC 60664-1	2002	Insulation coordination for equipment within low-voltage systems - Part 1: Principles, requirements and tests
IEC 60909-0	2001	Short-circuit currents in three-phase a.c. systems - Part 0: Calculation of currents
IEC 60865-1	1993	Short-circuit currents - Calculation of effects - Part 1: Definitions and calculation methods
IEC 60781	1989	Application guide for calculation of short-circuit currents in low-voltage radial systems
IEC 60076-1	2000	Power transformers - Part 1: General
IEC 60076-2	1993	Power transformers - Part 2: Temperature rise
IEC 60076-3	2000	Power transformers - Part 3: Insulation levels, dielectric tests and external clearances in air
IEC 60076-5	2006	Power transformers - Part 5: Ability to withstand short circuit
IEC/TR 60616	1978	Terminal and tapping markings for power transformers
IEC 60076-11	2004	Power transformers - Part 11: Dry-type transformers
IEC 60445	1999	Basic and safety principles for man-machine interface, marking and identification - Identification of equipment terminals and of terminations of certain designated conductors, including general rules for an alphanumeric system

## 1 Standards

STANDARD	YEAR	TITLE
IEC 60073	2002	Basic and safety principles for man-machine interface, marking and identification – Coding for indicators and actuators
IEC 60446	1999	Basic and safety principles for man-machine interface, marking and identification - Identification of conductors by colours or numerals
IEC 60447	2004	Basic and safety principles for man-machine interface, marking and identification - Actuating principles
IEC 60947-1	2004	Low-voltage switchgear and controlgear - Part 1: General rules
IEC 60947-2	2003	Low-voltage switchgear and controlgear - Part 2: Circuit-breakers
IEC 60947-3	2005	Low-voltage switchgear and controlgear - Part 3: Switches, disconnectors, switch-disconnectors and fuse-combination units
IEC 60947-4-1	2002	Low-voltage switchgear and controlgear - Part 4-1: Contactors and motor-starters – Electromechanical contactors and motor-starters
IEC 60947-4-2	2002	Low-voltage switchgear and controlgear - Part 4-2: Contactors and motor-starters – AC semiconductor motor controllers and starters
IEC 60947-4-3	1999	Low-voltage switchgear and controlgear - Part 4-3: Contactors and motor-starters – AC semiconductor controllers and contactors for non-motor loads
IEC 60947-5-1	2003	Low-voltage switchgear and controlgear - Part 5-1: Control circuit devices and switching elements - Electromechanical control circuit devices
IEC 60947-5-2	2004	Low-voltage switchgear and controlgear - Part 5-2: Control circuit devices and switching elements – Proximity switches
IEC 60947-5-3	2005	Low-voltage switchgear and controlgear - Part 5-3: Control circuit devices and switching elements – Requirements for proximity devices with defined behaviour under fault conditions
IEC 60947-5-4	2002	Low-voltage switchgear and controlgear - Part 5: Control circuit devices and switching elements – Section 4: Method of assessing the performance of low energy contacts. Special tests
IEC 60947-5-5	2005	Low-voltage switchgear and controlgear - Part 5-5: Control circuit devices and switching elements - Electrical emergency stop device with mechanical latching function

## 1 Standards

STANDARD	YEAR	TITLE
IEC 60947-5-6	1999	Low-voltage switchgear and controlgear - Part 5-6: Control circuit devices and switching elements – DC interface for proximity sensors and switching amplifiers (NAMUR)
IEC 60947-6-1	2005	Low-voltage switchgear and controlgear - Part 6-1: Multiple function equipment – Automatic transfer switching equipment
IEC 60947-6-2	2002	Low-voltage switchgear and controlgear - Part 6-2: Multiple function equipment - Control and protective switching devices (or equipment) (CPS)
IEC 60947-7-1	2002	Low-voltage switchgear and controlgear - Part 7: Ancillary equipment - Section 1: Terminal blocks for copper conductors
IEC 60947-7-2	2002	Low-voltage switchgear and controlgear - Part 7: Ancillary equipment - Section 2: Protective conductor terminal blocks for copper conductors
IEC 60439-1	2004	Low-voltage switchgear and controlgear assemblies - Part 1: Type-tested and partially type-tested assemblies
IEC 60439-2	2005	Low-voltage switchgear and controlgear assemblies - Part 2: Particular requirements for busbar trunking systems (busways)
IEC 60439-3	2001	Low-voltage switchgear and controlgear assemblies - Part 3: Particular requirements for low-voltage switchgear and controlgear assemblies intended to be installed in places where unskilled persons have access for their use - Distribution boards
IEC 60439-4	2004	Low-voltage switchgear and controlgear assemblies - Part 4: Particular requirements for assemblies for construction sites (ACS)
IEC 60439-5	1998	Low-voltage switchgear and controlgear assemblies - Part 5: Particular requirements for assemblies intended to be installed outdoors in public places - Cable distribution cabinets (CDCs) for power distribution in networks
IEC 61095	2000	Electromechanical contactors for household and similar purposes

## 1 Standards

STANDARD	YEAR	TITLE
IEC/TR 60890	1987	A method of temperature-rise assessment by extrapolation for partially type-tested assemblies (PTTA) of low-voltage switchgear and controlgear
IEC/TR 61117	1992	A method for assessing the short-circuit withstand strength of partially type-tested assemblies (PTTA)
IEC 60092-303	1980	Electrical installations in ships. Part 303: Equipment - Transformers for power and lighting
IEC 60092-301	1980	Electrical installations in ships. Part 301: Equipment - Generators and motors
IEC 60092-101	2002	Electrical installations in ships - Part 101: Definitions and general requirements
IEC 60092-401	1980	Electrical installations in ships. Part 401: Installation and test of completed installation
IEC 60092-201	1994	Electrical installations in ships - Part 201: System design - General
IEC 60092-202	1994	Electrical installations in ships - Part 202: System design - Protection
IEC 60092-302	1997	Electrical installations in ships - Part 302: Low-voltage switchgear and controlgear assemblies
IEC 60092-350	2001	Electrical installations in ships - Part 350: Shipboard power cables - General construction and test requirements
IEC 60092-352	2005	Electrical installations in ships - Part 352: Choice and installation of electrical cables
IEC 60364-5-52	2001	Electrical installations of buildings - Part 5-52: Selection and erection of electrical equipment – Wiring systems
IEC 60227		Polyvinyl chloride insulated cables of rated voltages up to and including 450/750 V
	1998	Part 1: General requirements
	2003	Part 2: Test methods
	1997	Part 3: Non-sheathed cables for fixed wiring
	1997	Part 4: Sheathed cables for fixed wiring
	2003	Part 5: Flexible cables (cords)
	2001	Part 6: Lift cables and cables for flexible connections
	2003	Part 7: Flexible cables screened and unscreened with two or more conductors
IEC 60228	2004	Conductors of insulated cables
IEC 60245		Rubber insulated cables - Rated voltages up to and including 450/750 V
	2003	Part 1: General requirements
	1998	Part 2: Test methods
	1994	Part 3: Heat resistant silicone insulated cables
	1994	Part 4: Cords and flexible cables

## 1 Standards

STANDARD	YEAR	TITLE
	2004	Part 4: Cord and flexible cables
	1994	Part 5: Lift cables
	1994	Part 6: Arc welding electrode cables
	1994	Part 7: Heat resistant ethylene-vinyl acetate rubber insulated cables
	2004	Part 8: Cords for applications requiring high flexibility
IEC 60309-2	2005	Plugs, socket-outlets and couplers for industrial purposes - Part 2: Dimensional interchangeability requirements for pin and contact-tube accessories
IEC 61008-1	2002	Residual current operated circuit-breakers without integral overcurrent protection for household and similar uses (RCCBs) - Part 1: General rules
IEC 61008-2-1	1990	Residual current operated circuit-breakers without integral overcurrent protection for household and similar uses (RCCBs). Part 2-1: Applicability of the general rules to RCCB's functionally independent of line voltage
IEC 61008-2-2	1990	Residual current operated circuit-breakers without integral overcurrent protection for household and similar uses (RCCB's). Part 2-2: Applicability of the general rules to RCCB's functionally dependent on line voltage
IEC 61009-1	2003	Residual current operated circuit-breakers with integral overcurrent protection for household and similar uses (RCBOs) - Part 1: General rules
IEC 61009-2-1	1991	Residual current operated circuit-breakers with integral overcurrent protection for household and similar uses (RCBO's) Part 2-1: Applicability of the general rules to RCBO's functionally independent of line voltage
IEC 61009-2-2	1991	Residual current operated circuit-breakers with integral overcurrent protection for household and similar uses (RCBO's) - Part 2-2: Applicability of the general rules to RCBO's functionally dependent on line voltage
IEC 60670-1	2002	Boxes and enclosures for electrical accessories for household and similar fixed electrical installations - Part 1: General requirements
IEC 60669-2-1	2002	Switches for household and similar fixed electrical installations - Part 2-1: Particular requirements – Electronic switches
IEC 60669-2-2	2002	Switches for household and similar fixed electrical installations - Part 2: Particular requirements – Section 2: Remote-control switches (RCS)
IEC 60669-2-3	1997	Switches for household and similar fixed electrical installations - Part 2-3: Particular requirements – Time-delay switches (TDS)

## 1 Standards

STANDARD	YEAR	TITLE
IEC 60079-10	2002	Electrical apparatus for explosive gas atmospheres - Part 10: Classification of hazardous areas
IEC 60079-14	2002	Electrical apparatus for explosive gas atmospheres - Part 14: Electrical installations in hazardous areas (other than mines)
IEC 60079-17	2002	Electrical apparatus for explosive gas atmospheres - Part 17: Inspection and maintenance of electrical installations in hazardous areas (other than mines)
IEC 60269-1	2005	Low-voltage fuses - Part 1: General requirements
IEC 60269-2	1986	Low-voltage fuses. Part 2: Supplementary requirements for fuses for use by authorized persons (fuses mainly for industrial application)
IEC 60269-3-1	2004	Low-voltage fuses - Part 3-1: Supplementary requirements for fuses for use by unskilled persons (fuses mainly for household and similar applications) - Sections I to IV: Examples of types of standardized fuses
IEC 60127-1/10		Miniature fuses -
	2003	Part 1: Definitions for miniature fuses and general requirements for miniature fuse-links
	2003	Part 2: Cartridge fuse-links
	1988	Part 3: Sub-miniature fuse-links
	2005	Part 4: Universal Modular Fuse-Links (UMF) Through-hole and surface mount types
	1988	Part 5: Guidelines for quality assessment of miniature fuse-links
	1994	Part 6: Fuse-holders for miniature cartridge fuse-links
	2001	Part 10: User guide for miniature fuses
IEC 60730-2-7	1990	Automatic electrical controls for household and similar use. Part 2-7: Particular requirements for timers and time switches
IEC 60364-1	2005	Low-voltage electrical installations Part 1: Fundamental principles, assessment of general characteristics, definitions
IEC 60364-4-41	2005	Low-voltage electrical installations Part 4-41: Protection for safety - Protection against electric shock
IEC 60364-4-42	2001	Electrical installations of buildings Part 4-42: Protection for safety - Protection against thermal effects
IEC 60364-4-43	2001	Electrical installations of buildings Part 4-43: Protection for safety - Protection against overcurrent

## 1 Standards

STANDARD	YEAR	TITLE
IEC 60364-4-44	2003	Electrical installations of buildings Part 4-44: Protection for safety - Protection against voltage disturbances and electromagnetic disturbances
IEC 60364-5-51	2005	Electrical installations of buildings Part 5-51: Selection and erection of electrical equipment Common rules
IEC 60364-5-52	2001	Electrical installations of buildings Part 5-52: Selection and erection of electrical equipment Wiring systems
IEC 60364-5-53	2002	Electrical installations of buildings Part 5-53: Selection and erection of electrical equipment Isolation, switching and control
IEC 60364-5-54	2002	Electrical installations of buildings Part 5-54: Selection and erection of electrical equipment Earthing arrangements, protective conductors and protective bonding conductors
IEC 60364-5-55	2002	Electrical installations of buildings Part 5-55: Selection and erection of electrical equipment Other equipment
IEC 60364-6-61	2001	Electrical installations of buildings Part 6-61: Verification - Initial verification
IEC 60364-7	1984...2005	Electrical installations of buildings Part 7: Requirements for special installations or locations
IEC 60529	2001	Degrees of protection provided by enclosures (IP Code)
IEC 61032	1997	Protection of persons and equipment by enclosures - Probes for verification
IEC/TR 61000-1-1	1992	Electromagnetic compatibility (EMC) Part 1: General - Section 1: application and interpretation of fundamental definitions and terms
IEC/TR 61000-1-2	2001	Electromagnetic compatibility (EMC) Part 1-2: General - Methodology for the achievement of the functional safety of electrical and electronic equipment with regard to electromagnetic phenomena
IEC/TR 61000-1-3	2002	Electromagnetic compatibility (EMC) Part 1-3: General - The effects of high-altitude EMP (HEMP) on civil equipment and systems

## 2 Protection and control devices

### 2.1 Circuit-breaker nameplates

Moulded-case circuit-breaker: Tmax

CIRCUIT-BREAKER TYPE							
Series <b>T</b>	Size <b>1</b> <b>2</b> <b>3</b> <b>4</b> <b>5</b> <b>6</b> <b>7</b>	Rated ultimate short-circuit breaking capacity at 415 Vac <b>B</b> = 16 kA <b>C</b> = 25 kA <b>N</b> = 36 kA <b>S</b> = 50 kA <b>H</b> = 70 kA <b>L</b> = 85 kA (for T2) <b>L</b> = 120 kA (for T4-T5-T7) <b>L</b> = 100 kA (for T6) <b>V</b> = 150 kA (for T7) <b>V</b> = 200 kA				Rated uninterrupted current <b>160 A</b> <b>250 A</b> <b>320 A</b> <b>400 A</b> <b>630 A</b> <b>800 A</b> <b>1000 A</b> <b>1250 A</b> <b>1600 A</b>	

Tmax	T2L	160	Iu=160A Ue=690V Ui=800V Uimp=8kV				IEC 60947-2	
Ue (V)	230	400/415	440	500	690	250	500	Made in Italy by ABB SACE
Icu (kA)	150	85	75	50	10	85	85	CE
Ics (%Icu)	75	75	75	75	75	75	75	
Cat A	~ 50-60Hz			2 P --- 3 P in series				

Rated ultimate short-circuit breaking capacity (**Icu**) and rated service short-circuit breaking capacity (**Ics**) at different voltage values.

According to the international Standard IEC 60947-2, the circuit breakers can be divided into Category **A**, i.e. without a specified short-time withstand current rating, or Category **B**, i.e. with a specified short-time withstand current rating.

**CE** marking affixed on ABB circuit-breakers to indicate compliance with the following CE directives: "Low Voltage Directive" (LVD) no. 73/23 EEC "Electromagnetic Compatibility Directive" (EMC) no. 89/336 EEC.

Rated impulse withstand voltage **Uimp**: i.e. the peak value of impulse voltage which the circuit-breaker can withstand under specified test conditions.

Compliance with the international Standard **IEC 60947-2**: "Low-Voltage switchgear and controlgear-Circuit-breakers".

Rated insulation voltage **Ui**; i.e. the maximum r.m.s. value of voltage which the circuit-breaker is capable of withstanding at the supply frequency under specified test conditions.

Rated operational voltage **Ue**

Rated uninterrupted current **Iu**

ASDC008046F0201

Moulded-case circuit-breaker: Isomax

CIRCUIT-BREAKER TYPE							
Series <b>S</b>	Size <b>7</b>	Rated ultimate short-circuit breaking capacity at 415 Vac <b>S</b> = 50 kA <b>H</b> = 65 kA <b>L</b> = 100 kA					

SACE S7L	Iu=1250A Ue=690V IEC 947-2 CEI EN 60947-2					IEC 60947-2	
Ue (V)	230	400/415	440	500	690	Ics = 50% Icu	
Icu 50-60 Hz (kA)	200	100	80	70	35	Cat B	

Rated ultimate short-circuit breaking capacity (**Icu**) at different voltage values.

Compliance with national and international product Standards.

Rated impulse withstand voltage **Uimp**: i.e. the peak value of impulse voltage which the circuit-breaker can withstand under specified test conditions.

Compliance with the international Standard **IEC 60947-2**: "Low-Voltage switchgear and controlgear-Circuit-breakers".

Rated insulation voltage **Ui**; i.e. the maximum r.m.s. value of voltage which the circuit-breaker is capable of withstanding at the supply frequency under specified test conditions.

Rated operational voltage **Ue**

Rated uninterrupted current **Iu**

According to the international Standard **IEC 60947-2**: "Low-Voltage switchgear and controlgear-Circuit-breakers".

According to the international Standard IEC 60947-2, the circuit-breakers can be divided into Category **A**, i.e. without a specified short-time withstand current rating, or Category **B**, i.e. with a specified short-time withstand current rating.

**CE** marking affixed on ABB circuit-breakers to indicate compliance with the following CE directives: "Low Voltage Directive" (LVD) no. 73/23 EEC "Electromagnetic Compatibility Directive" (EMC) no. 89/336 EEC.

ASDC008047F0201

## 2 Protection and control devices

### Air circuit-breaker: Emax

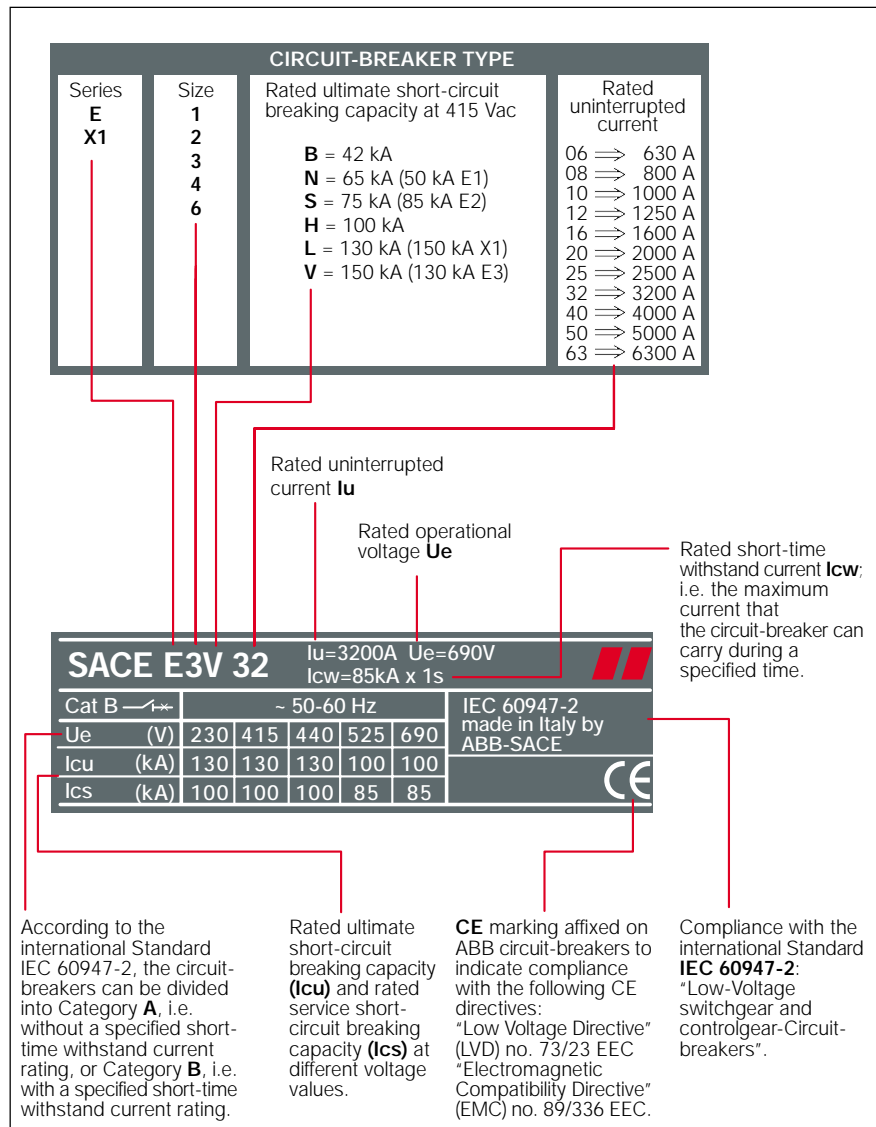

## 2 Protection and control devices

### 2.2 Main definitions

The main definitions regarding LV switchgear and controlgear are included in the international Standards IEC 60947-1, IEC 60947-2 and IEC 60947-3.

#### Main characteristics

##### *Circuit-breaker*

A mechanical switching device, capable of making, carrying and breaking currents under normal circuit conditions and also making, carrying for a specified time and breaking currents under specified abnormal circuit conditions such as those of short-circuit.

##### *Current-limiting circuit-breaker*

A circuit-breaker with a break-time short enough to prevent the short-circuit current reaching its otherwise attainable peak value.

##### *Plug-in circuit-breaker*

A circuit-breaker which, in addition to its interrupting contacts, has a set of contacts which enable the circuit-breaker to be removed.

##### *Withdrawable circuit-breaker*

A circuit-breaker which, in addition to its interrupting contacts, has a set of isolating contacts which enable the circuit-breaker to be disconnected from the main circuit, in the withdrawn position, to achieve an isolating distance in accordance with specified requirements.

##### *Moulded-case circuit-breaker*

A circuit-breaker having a supporting housing of moulded insulating material forming an integral part of the circuit-breaker.

##### *Disconnecter*

A mechanical switching device which, in the open position, complies with the requirements specified for the isolating function.

##### *Release*

A device, mechanically connected to a mechanical switching device, which releases the holding means and permits the opening or the closing of the switching device.

#### Fault types and currents

##### *Overload*

Operating conditions in an electrically undamaged circuit which cause an over-current.

##### *Short-circuit*

The accidental or intentional connection, by a relatively low resistance or impedance, of two or more points in a circuit which are normally at different voltages.

##### *Residual current ( $I_{\Delta}$ )*

It is the vectorial sum of the currents flowing in the main circuit of the circuit-breaker.



## 2 Protection and control devices

### Rated performances

#### Voltages and frequencies

##### **Rated operational voltage ( $U_e$ )**

A rated operational voltage of an equipment is a value of voltage which, combined with a rated operational current, determines the application of the equipment and to which the relevant tests and the utilization categories are referred to.

##### **Rated insulation voltage ( $U_i$ )**

The rated insulation voltage of an equipment is the value of voltage to which dielectric tests voltage and creepage distances are referred. In no case the maximum value of the rated operational voltage shall exceed that of the rated insulation voltage.

##### **Rated impulse withstand voltage ( $U_{imp}$ )**

The peak value of an impulse voltage of prescribed form and polarity which the equipment is capable of withstanding without failure under specified conditions of test and to which the values of the clearances are referred.

##### **Rated frequency**

The supply frequency for which an equipment is designed and to which the other characteristic values correspond.

#### Currents

##### **Rated uninterrupted current ( $I_u$ )**

The rated uninterrupted current of an equipment is a value of current, stated by the manufacturer, which the equipment can carry in uninterrupted duty.

##### **Rated residual operating current ( $I_{\Delta n}$ )**

It is the r.m.s. value of a sinusoidal residual operating current assigned to the CBR by the manufacturer, at which the CBR shall operate under specified conditions.

### Performances under short-circuit conditions

##### **Rated making capacity**

The rated making capacity of an equipment is a value of current, stated by the manufacturer, which the equipment can satisfactorily make under specified making conditions.

##### **Rated breaking capacity**

The rated breaking of an equipment is a value of current, stated by the manufacturer, which the equipment can satisfactorily break, under specified breaking conditions.

## 2 Protection and control devices

##### **Rated ultimate short-circuit breaking capacity ( $I_{cu}$ )**

The rated ultimate short-circuit breaking capacity of a circuit-breaker is the maximum short-circuit current value which the circuit-breaker can break twice (in accordance with the sequence O – t – CO), at the corresponding rated operational voltage. After the opening and closing sequence the circuit-breaker is not required to carry its rated current.

##### **Rated service short-circuit breaking capacity ( $I_{cs}$ )**

The rated service short-circuit breaking capacity of a circuit-breaker is the maximum short-circuit current value which the circuit-breaker can break three times in accordance with a sequence of opening and closing operations (O - t - CO - t - CO) at a defined rated operational voltage ( $U_e$ ) and at a defined power factor. After this sequence the circuit-breaker is required to carry its rated current.

##### **Rated short-time withstand current ( $I_{cw}$ )**

The rated short-time withstand current is the current that the circuit-breaker in the closed position can carry during a specified short time under prescribed conditions of use and behaviour; the circuit-breaker shall be able to carry this current during the associated short-time delay in order to ensure discrimination between the circuit-breakers in series.

##### **Rated short-circuit making capacity ( $I_{cm}$ )**

The rated short-circuit making capacity of an equipment is the value of short-circuit making capacity assigned to that equipment by the manufacturer for the rated operational voltage, at rated frequency, and at a specified power-factor for ac.

### Utilization categories

The utilization category of a circuit-breaker shall be stated with reference to whether or not it is specifically intended for selectivity by means of an intentional time delay with respect to other circuit-breakers in series on the load side, under short-circuit conditions (Table 4 IEC 60947-2).

**Category A** - Circuit-breakers not specifically intended for selectivity under short-circuit conditions with respect to other short-circuit protective devices in series on the load side, i.e. without a short-time withstand current rating.

**Category B** - Circuit-breakers specifically intended for selectivity under short-circuit conditions with respect to other short-circuit protective devices in series on the load side, i.e. with and intentional short-time delay provided for selectivity under short-circuit conditions. Such circuit-breakers have a short-time withstand current rating.





## 2 Protection and control devices

For example, a circuit-breaker type T2, with rated current  $I_n$  equal to 2.5 A, is available in two versions:

- thermomagnetic with adjustable thermal current  $I_1$  from 1.8 up to 2.5 A and fixed magnetic current  $I_3$  equal to 25 A;
- fixed magnetic only releases (MF) with  $I_3$  equal to 33 A.

### 2.3.2 ELECTRONIC RELEASES

These releases are connected with current transformers (three or four according to the number of conductors to be protected), which are positioned inside the circuit-breaker and have the double functions of supplying the power necessary to the proper functioning of the release (self-supply) and of detecting the value of the current flowing inside the live conductors; therefore they are compatible with alternating current networks only.

The signal coming from the transformers and from the Rogowsky coils is processed by the electronic component (microprocessor) which compares it with the set thresholds. When the signal exceeds the thresholds, the trip of the circuit-breaker is operated through an opening solenoid which directly acts on the circuit-breaker operating mechanism.

In case of auxiliary power supply in addition to self-supply from the current transformers, the voltage shall be 24 Vdc  $\pm$  20%.

Rated Current In [A]		10	25	63	100	160	200	250	320	400	630	800	1000	1250	1600
L function	PR221	4-10	10-25	25-63	40-100	64-160		100-250	128-320	160-400	252-630	320-800	400-1000		
	PR222				40-100	64-160		100-250	128-320	160-400	252-630	320-800	400-1000		
	PR223				18-100	28.8-160		45-250	57.6-320	72-400	113.4-630	144-800	180-1000		
	PR231								160-400	252-630	320-800	400-1000	500-1250	640-1600	
	PR232								160-400	252-630	320-800	400-1000	500-1250	640-1600	
	PR331								160-400	252-630	320-800	400-1000	500-1250	640-1600	
	PR332								160-400	252-630	320-800	400-1000	500-1250	640-1600	
	PR211/PR212											400-1000	500-1250	640-1600	
	PR222/MP				40-100	64-160	80-200		128-320	160-400	252-630				
	PR212/MP												400-1000		
S function	PR221	10-100	25-250	63-630	100-1000	160-1600		250-2500	320-3200	400-4000	630-6300	800-8000	1000-10000		
	PR222				60-1000	96-1600		150-2500	192-3200	240-4000	378-6300	480-8000	600-10000		
	PR223				60-1000	96-1600		150-2500	192-3200	240-4000	378-6300	480-8000	600-10000		
	PR231								400-4000	630-6300	800-8000	1000-10000	1250-12500	1600-16000	
	PR232								240-4000	378-6300	480-8000	600-10000	750-12500	960-16000	
	PR331								240-4000	378-6300	480-8000	600-10000	750-12500	960-16000	
	PR332								240-4000	378-6300	480-8000	600-10000	750-12500	960-16000	
	PR211/PR212											1000-10000	1250-12500	1600-16000	
I function	PR221	10-100	25-250	63-630	100-1000	160-1600		250-2500	320-3200	400-4000	630-6300	800-8000	1000-10000		
	PR222				150-1200	240-1920		375-3000	480-3840	600-4800	945-7560	1200-9600	1500-12000		
	PR223				150-1200	240-1920		375-3000	480-3840	600-4800	945-7560	1200-9600	1500-12000		
	PR231								400-4800	630-7560	800-9600	1000-12000	1250-15000	1600-19200	
	PR232								600-4800	945-7560	1200-9600	1500-12000	1875-15000	2400-19200	
	PR331								600-6000	945-9450	1200-12000	1500-15000	1875-15000	2400-19200	
	PR332								600-6000	945-9450	1200-12000	1500-15000	1875-15000	2400-19200	
	PR211/PR212												2875-15000	2400-19200	
	PR222/MP				600-1300	960-2080	1200-2600		1920-4160	2400-5200	3780-8190		6000-13000		
	PR212/MP												6000-13000		

## 2 Protection and control devices

Besides the standard protection functions, releases provide:

- measurements of currents (PR222, PR232, PR331, PR121);
- measurement of currents, voltage, frequency, power, energy, power factor (PR223, PR332, PR122) and moreover for PR333 and PR123, the measurement of harmonic distortions is available;
- serial communication with remote control for a complete management of the plant (PR212, PR222, PR223, PR232, PR331, PR332, PR333, PR121, PR122, PR123).

### CURRENT TRANSFORMER SIZE

Rated current In [A] →	10	25	63	100	160	250	320	400	630	800	1000	1250	1600
Circuit-breaker	I <sub>n</sub> [A]												
T2	160												
T4	250												
	320												
T5	400												
	630												
T6	630												
	800												
	1000												
T7	800												
	1000												
	1250												
	1600												
S7	1250												
	1600												

## 2 Protection and control devices

### CURRENT TRANSFORMER SIZE

#### Rating plugs

Type of circuit-breaker	Rated current I <sub>n</sub>	In [A]	400	630	800	1000	1250	1600	2000	2500	3200	4000	5000	6300
X1B - X1N	630													
	800													
	1000													
	1250													
X1L	1600													
	630													
	800													
	1000													
E1B	1250													
	1600													
	800													
	1000-1250													
E1N	1600													
	800													
	1000-1250													
	1600													
E2B	2000													
	1000-1250													
	1600													
	2000													
E2N	800													
	1000-1250													
	1600													
	2000													
E2S	800													
	1000-1250													
	1600													
	2000													
E2L	1250													
	1600													
	2500													
	3200													
E3N	1000-1250													
	1600													
	2000													
	2500													
E3S	3200													
	800													
	1000-1250													
	1600													
E3H	2000													
	2500													
	3200													
	800													
E3V	1000-1250													
	1250													
	1600													
	2000													
E3L	2500													
	4000													
	3200													
	4000													
E4S, E4S/f	3200													
	4000													
	E4H, E4H/f	4000												
	3200													
E4V	4000													
	4000													
	E6H, E6H/f	5000												
	6300													
E6V	3200													
	4000													
	5000													
	6300													

Rated current In [A] →		400	630	800	1000	1250	1600	2000	2500	3200	4000	5000	6300	
<b>L</b>	Function	PR121/PR122/PR123 PR331/PR332/PR333	160+400	252+630	320+800	400+1000	500+1250	640+1600	800+2000	1000+2500	1280+3200	1600+4000	2000+5000	2520+6300
	<b>S</b>	Function	PR121	400+4000	630+6300	800+8000	1000+10000	1250+12500	1600+16000	2000+20000	2500+25000	3200+32000	4000+40000	5000+50000
<b>I</b>	Function	PR122/PR123 PR331/PR332/PR333	240+4000	378+6300	480+8000	600+10000	750+12500	960+16000	1200+20000	1500+25000	1920+32000	2400+40000	3000+50000	3780+63000
	Function	PR121/PR122/PR123 PR331/PR332/PR333	600+6000	945+9450	1200+12000	1500+15000	1875+18750	2400+24000	3000+30000	3750+37500	4800+48000	6000+60000	7500+75000	9450+94500

## 2 Protection and control devices

### 2.3.2.1 PROTECTION FUNCTIONS OF ELECTRONIC RELEASES

The protection functions available for the electronic releases are:

#### L - Overload protection with inverse long time delay

Function of protection against overloads with inverse long time delay and constant specific let-through energy; it cannot be excluded.

#### L - Overload protection in compliance with Std. IEC 60255-3

Function of protection against overloads with inverse long time delay and trip curves complying with IEC 60255-3; applicable in the coordination with fuses and with medium voltage protections.

#### S - Short-circuit protection with adjustable delay

Function of protection against short-circuit currents with adjustable delay; thanks to the adjustable delay, this protection is particularly useful when it is necessary to obtain selective coordination between different devices.

#### S<sub>2</sub> - Double S

This function allows two thresholds of protection function S to be set independently and activated simultaneously, selectivity can also be achieved under highly critical conditions.

#### D - Directional short-circuit protection with adjustable delay

The directional protection, which is similar to function S<sub>1</sub>, can intervene in a different way according to the direction of the short-circuit current; particularly suitable in meshed networks or with multiple supply lines in parallel.

#### I - Short-circuit protection with instantaneous trip

Function for the instantaneous protection against short-circuit.

#### EFDP - Early Fault Detection and Prevention

Thanks to this function, the release is able to isolate a fault in shorter times than the zone selectivities currently available on the market.

#### Rc - Residual current protection

This function is particularly suitable where low-sensitivity residual current protection is required and for high-sensitivity applications to protect people against indirect contact.

#### G - Earth fault protection with adjustable delay

Function protecting the plant against earth faults.

#### U - Phase unbalance protection

Protection function which intervenes when an excessive unbalance between the currents of the single phases protected by the circuit-breaker is detected.

## 2 Protection and control devices

### OT - Self-protection against overtemperature

Protection function controlling the opening of the circuit-breaker when the temperature inside the release can jeopardize its functioning.

### UV - Undervoltage protection

Protection function which intervenes when the phase voltage drops below the preset threshold.

### OV - Overvoltage protection

Protection function which intervenes when the phase voltage exceeds the preset threshold.

### RV - Residual voltage protection

Protection which identifies anomalous voltages on the neutral conductor.

### RP - Reverse power protection

Protection which intervenes when the direction of the active power is opposite to normal operation.

### UF - Under frequency protection

This frequency protection detects the reduction of network frequency above the adjustable threshold, generating an alarm or opening the circuit.

### OF - Overfrequency protection

This frequency protection detects the increase of network frequency above the adjustable threshold, generating an alarm or opening the circuit.

### M - Thermal memory

Thanks to this function, it is possible to take into account the heating of a component so that the tripping is the quicker the less time has elapsed since the last one.

### R - Protection against rotor blockage

Function intervening as soon as conditions are detected, which could lead to the block of the rotor of the protected motor during operation.

### linst - Very fast instantaneous protection against short-circuit

This particular protection function has the aim of maintaining the integrity of the circuit-breaker and of the plant in case of high currents requiring delays lower than those guaranteed by the protection against instantaneous short-circuit. This protection must be set exclusively by ABB SACE and cannot be excluded.

### Dual setting

With this function it is possible to program two different sets of parameters (LSIG) and, through an external command, to switch from one set to the other.

### K - Load control

Thanks to this function, it is possible to engage/disengage individual loads on the load side before the overload protection L trips.

## 2 Protection and control devices

The following table summarizes the types of electronic release and the functions they implement:

		PR211	PR212	PR221	PR222	PR223	PR231	PR232	PR331	PR332	PR333	PR121	PR122	PR123	Releases	
		Protection functions														
■	■	■	■	■	■	■	■	■	■	■	■	■	■	■	L (t=k/I <sup>2</sup> )	Protection against overload
■	■	■	■	■	■	■	■	■	■	■	■	■	■	■	S1 (t=k)	Protection against short-circuit with time delay
■	■	■	■	■	■	■	■	■	■	■	■	■	■	■	S1 (t=k/I <sup>2</sup> )	Protection against short-circuit with time delay
														■	S2 (t=k)	Protection against short-circuit with time delay
														■	D (t=k)	Protection against directional short-circuit
■	■	■	■	■	■	■	■	■	■	■	■	■	■	■	I (t=k)	Protection against instantaneous short-circuit
														■	G (t=k)	Protection against earth fault with adjustable delay
■	■	■	■	■	■	■	■	■	■	■	■	■	■	■	G (t=k/I <sup>2</sup> )	Protection against earth fault with adjustable delay
														■	Gext (t=k)	Protection against earth fault with adjustable delay
														■	Gext (t=k/I <sup>2</sup> )	Protection against earth fault with adjustable delay
														■	Gext (Idn)	Protection against earth fault with adjustable delay
														○	Rc (t=k)	Residual current protection
														■	U (t=k)	Protection against phase unbalance
														■	OT	Protection against temperature out of range
														○	UV (t=k)	Protection against undervoltage
														○	OV (t=k)	Protection against overvoltage
														○	RV (t=k)	Protection against residual voltage
														○	RP (t=k)	Protection against reverse active power
														○	UF	Protection against underfrequency
														○	OF	Protection against overfrequency
														■	linst	Instantaneous self-protection
														■	EF	Early Fault Detection and Prevention

○ Only with PR120/V for Emax and PR330/V for X1

## 2 Protection and control devices

### 2.3.3 RESIDUAL CURRENT DEVICES

The residual current releases are associated with the circuit-breaker in order to obtain two main functions in a single device:

- protection against overloads and short-circuits;
- protection against indirect contacts (presence of voltage on exposed conductive parts due to loss of insulation).

Besides, they can guarantee an additional protection against the risk of fire deriving from the evolution of small fault or leakage currents which are not detected by the standard protections against overload.

Residual current devices having a rated residual current not exceeding 30 mA are also used as a means for additional protection against direct contact in case of failure of the relevant protective means.

Their logic is based on the detection of the vectorial sum of the line currents through an internal or external toroid.

This sum is zero under service conditions or equal to the earth fault current ( $I_{\Delta}$ ) in case of earth fault.

When the release detects a residual current different from zero, it opens the circuit-breaker through an opening solenoid.

As we can see in the picture the protection conductor or the equipotential conductor have to be installed outside the eventual external toroid.

#### Generic distribution system (IT, TT, TN)

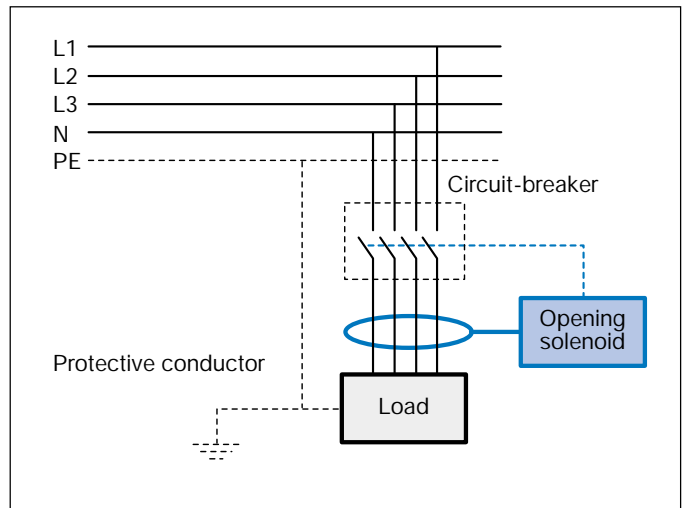

The operating principle of the residual current release makes it suitable for the distribution systems TT, IT (even if paying particular attention to the latter) and TN-S, but not in the systems TN-C. In fact, in these systems, the neutral is used also as protective conductor and therefore the detection of the residual current would not be possible if the neutral passes through the toroid, since the vectorial sum of the currents would always be equal to zero.

## 2 Protection and control devices

One of the main characteristics of a residual current release is its minimum rated residual current  $I_{\Delta n}$ . This represents the sensitivity of the release.

According to their sensitivity to the fault current, the residual current circuit-breakers are classified as:

- type AC: a residual current device for which tripping is ensured in case of residual sinusoidal alternating current, in the absence of a dc component whether suddenly applied or slowly rising;
- type A: a residual current device for which tripping is ensured for residual sinusoidal alternating currents in the presence of specified residual pulsating direct currents, whether suddenly applied or slowly rising.
- type B residual current device for which tripping is ensured for residual sinusoidal alternating currents in presence of specified residual pulsating direct currents whether suddenly applied or slowly rising, for residual direct currents may result from rectifying circuits.

	Form of residual current	Correct functioning of residual current devices Type		
		AC	A	B
Sinusoidal ac	suddenly applied			
	slowly rising	+	+	+
Pulsating dc	suddenly applied with or without $\uparrow$ 0,006A		+	+
	slowly rising			
Smooth dc				+

ASDC080003F0201

In presence of electrical apparatuses with electronic components (computers, photocopiers, fax etc.) the earth fault current might assume a non sinusoidal shape but a type of a pulsating unidirectional dc shape. In these cases it is necessary to use a residual current release classified as type A.

In presence of rectifying circuits (i.e. single phase connection with capacitive load causing smooth direct current, three pulse star connection or six pulse bridge connection, two pulse connection line-to-line) the earth fault current might assume a unidirectional dc shape.

## 2 Protection and control devices

In this case it is necessary to use a residual current release classified as type B. The following table shows the main characteristics of ABB SACE residual current devices; they can be mounted both on circuit-breakers as well as on switch disconnectors (in case of fault currents to earth lower than the apparatus breaking capacity), are type A devices and they do not need auxiliary supply since they are self-supplied.

	RC221		RC222	
	T1-T2-T3 T1D-T3D	T1-T2-T3 T1D-T3D	T4 T4D	T5 T5D
Suitable for circuit-breaker type				
Primary service voltage [V]	85-500	85-500	85-500	85-500
Rated service current [A]	250	250	250	400
Rated residual current trip $I_{\Delta n}$ [A]	0.03-0.1-0.3- 0.5-1-3	0.03-0.05-0.1- 0.3-0.5-1 3-5-10	0.03-0.05-0.1- 0.3-0.5-1 3-5-10	0.03-0.05-0.1- 0.3-0.5-1 3-5-10
Time limit for non-trip (at $2x I_{\Delta n}$ ) [s]	Instantaneous	Inst.-0.1-0.2- 0.3-0.5-1-2-3	Inst.-0.1-0.2- 0.3-0.5-1-2-3	Inst.-0.1-0.2- 0.3-0.5-1-2-3
Tolerance over trip times [%]		± 20	± 20	± 20

Note: for detailed information, please consult the relevant technical catalogues.

Emax air circuit-breakers can be equipped with a toroid fitted on the back of the circuit-breaker so as to ensure protection against earth faults. In particular, the electronic release types able to perform this function are:

- PR122/P LSIRc-PR332/P LSIRc with homopolar toroid
- PR122/P LSIG-PR332/P LSIG with "Measuring module" and homopolar toroid
- PR123/P LSIG-PR333/P LSIG with homopolar toroid

which can all be provided for the following types of circuit-breakers: X1-E2 and E3, both three and four pole version, and E4 (three pole version).

Along with the family of residual current releases illustrated previously, ABB SACE is developing the RC223 (B type) residual current release, which can only be combined with the Tmax T4 four-pole circuit-breaker in the fixed or plug-in version. It is characterized by the same types of reference as the RC222 (S and AE type) release, but can also boast conformity with type B operation, which guarantees sensitivity to residual fault currents with alternating, alternating pulsating and direct current components.

Apart from the signals and settings typical of the RC222 residual current release, the RC223 also allows selection of the maximum threshold of sensitivity to the residual fault frequency (3 steps: 400 – 700 – 1000 Hz). It is therefore possible to adapt the residual current device to the different requirements of the industrial plant according to the prospective fault frequencies generated on the load side of the release.

## 2 Protection and control devices

ABB SACE moulded-case circuit-breakers series Isomax<sup>1</sup> and Tmax and air circuit-breakers series Emax<sup>1</sup> can be combined with the switchboard residual current relay type RCO, type A, with separate toroid (to be installed externally on the line conductors).

<sup>1</sup> up to 2000 A rated currents

			RCO
Power supply voltage	ac	[V]	80 ÷ 500
	dc	[V]	48÷125
Trip threshold adjustments $I_{\Delta n}$			
1 <sup>st</sup> range of adjustments		[A]	0.03 – 0.05 - 0.1 - 0.3 – 0.5
2 <sup>nd</sup> range of adjustments		[A]	1 – 3 – 5 – 10 - 30
Trip time adjustment		[s]	0 - 0.1 - 0.2 - 0.3 - 0.5 - 0.7 - 1 - 2 - 3 - 5
Tolerance over Trip times		[%]	± 20

Note: for detailed information, please consult the relevant technical catalogues.

The versions with adjustable trip times allow to obtain a residual current protection system coordinated from a discrimination point of view, from the main switchboard up to the ultimate load.



### 3 General characteristics

#### SACE Isomax moulded-case circuit-breakers

Rated uninterrupted current, <b>I<sub>u</sub></b>	[A]
Poles	No.
Rated operational voltage, <b>U<sub>e</sub></b>	(ac) 50-60Hz [V] (dc) [V]
Rated impulse withstand voltage, <b>U<sub>imp</sub></b>	[kV]
Rated insulation voltage, <b>U<sub>i</sub></b>	[V]
Test voltage at industrial frequency for 1 min.	[V]
Rated ultimate short-circuit breaking capacity, <b>I<sub>cu</sub></b>	
(ac) 50-60 Hz 220/230 V	[kA]
<b>(ac) 50-60 Hz 380/415 V</b>	<b>[kA]</b>
(ac) 50-60 Hz 440 V	[kA]
(ac) 50-60 Hz 500 V	[kA]
(ac) 50-60 Hz 690 V	[kA]
(dc) 250 V - 2 poles in series	[kA]
(dc) 500 V - 2 poles in series	[kA]
(dc) 500 V - 3 poles in series	[kA]
(dc) 750 V - 3 poles in series	[kA]
Rated short-circuit service breaking capacity, <b>I<sub>cs</sub></b>	[%I <sub>cu</sub> ]
Rated short-circuit making capacity (415 V) <b>I<sub>cm</sub></b>	[kA]
Opening time (415V at I <sub>cu</sub> )	[ms]
Rated short-time withstand current for 1 s, <b>I<sub>cw</sub></b>	[kA]
Utilization category (EN 60947-2)	
Isolation behaviour	
IEC 60947-2, EN 60947-2	
Releases: thermomagnetic	T adjustable, M adjustable TMA
	T adjustable, M fixed 2,5 In TMG
with microprocessor	PR211/P (I-LI) PR212/P (LSI-LSIG)
Interchangeability	
Versions	
Terminals	fixed
	plug-in withdrawable (1)
Mechanical life	[No. operations / operations per hours]
Electrical life (at 415 V)	[No. operations / operations per hours]
Basic dimensions, fixed	3/4 poles
	L [mm]
	D [mm]
	H [mm]
Weights	fixed 3/4 poles [kg]
	plug-in 3/4 poles [kg]
	withdrawable 3/4 poles [kg]

(1) The withdrawable version circuit-breakers must be fitted with the front flange for the lever operating mechanism or with its alternative accessories, such as the rotary handle or the motor operator

KEY TO VERSIONS  
F = Fixed  
P = Plug-in  
W = Withdrawable

### 3 General characteristics

S7		
1250 - 1600		
3-4		
690		
-		
8		
800		
3000		
<b>S</b>	<b>H</b>	<b>L</b>
85	100	200
<b>50</b>	<b>65</b>	<b>100</b>
40	55	80
35	45	70
20	25	35
-	-	-
-	-	-
-	-	-
-	-	-
100%	75%	50%
105	143	220
22	22	22
15 (1250A) - 20 (1600A)		
B		
■		
■		
-		
-		
■	■	■
■	■	■
-		
F - W		
F - EF - ES -		
FC CuAl (1250A)		
HR - VR		
-		
EF - HR - VR		
10000/120		
7000(1250A)-		
5000(1600A)/20		
210/280		
138.5		
406		
17 / 22		
-		
21.8 / 29.2		

KEY TO TERMINALS  
F = Front  
EF = Extended front  
ES = Extended spreaded front



### 3 General characteristics

#### Tmax moulded-case circuit-breakers for motor protection

	Tmax T2				Tmax T3	
Rated uninterrupted current, <b>Iu</b>	160				250	
Rated service current, <b>In</b>	1...100				100...200	
Poles	3				3	
Rated service current, <b>Iue</b>	(AC) 50-60 Hz (DC) 500				690 500	
Rated impulse withstand voltage, <b>Uimp</b>	8				8	
Rated insulation voltage, <b>Ui</b>	800				800	
Test voltage at industrial frequency for 1 min.	3000				3000	
Rated ultimate short-circuit breaking capacity, <b>Icu</b>	<b>N</b>	<b>S</b>	<b>H</b>	<b>L</b>	<b>N</b>	<b>S</b>
(AC) 50-60 Hz 220/230 V	65	85	100	120	50	85
(AC) 50-60 Hz 380/415 V	36	50	70	85	36	50
(AC) 50-60 Hz 440 V	30	45	55	75	25	40
(AC) 50-60 Hz 500 V	25	30	36	50	20	30
(AC) 50-60 Hz 690 V	6	7	8	10	5	8
Rated service short-circuit breaking capacity, <b>Ics</b>						
(AC) 50-60 Hz 220/230 V	100%	100%	100%	100%	75%	50%
(AC) 50-60 Hz 380/415 V	100%	100%	100%	75% (70 kA)	75%	50% (27 kA)
(AC) 50-60 Hz 440 V	100%	100%	100%	75%	75%	50%
(AC) 50-60 Hz 500 V	100%	100%	100%	75%	75%	50%
(AC) 50-60 Hz 690 V	100%	100%	100%	75%	75%	50%
Rated short-circuit making capacity, <b>Icm</b>						
(AC) 50-60 Hz 220/230 V	143	187	220	264	105	187
(AC) 50-60 Hz 380/415 V	75.6	105	154	187	75.6	105
(AC) 50-60 Hz 440 V	63	94.5	121	165	52.5	84
(AC) 50-60 Hz 500 V	52.5	63	75.6	105	40	63
(AC) 50-60 Hz 690 V	9.2	11.9	13.6	17	7.7	13.6
Opening time (415 V)	3	3	3	3	7	6
Utilisation category (IEC 60947-2)	A				A	
Isolation behaviour	■				■	
Reference Standard	IEC 60947-2				IEC 60947-2	
Protection against short-circuit	■ (MF up to In 12.5 A)				■	
Magnetic only trip unit	MA				■	
Electronic trip unit	PR221DS-I PR231/P-I				■ ■	
Integrated protection (IEC 60947-4-1)	■				■	
Electronic trip unit	PR222MP				■	
Interchangeability	■				■	
Versions	F - P				F - P	
Terminals	fixed	F - FC Cu - FC CuAl - EF - ES - R - FC CuAl			F - FC Cu - FC CuAl - EF - ES - R - FC CuAl	F - FC Cu - FC CuAl - EF - ES - R - FC CuAl
plug-in		F - FC Cu - FC CuAl - EF - ES - R - FC CuAl			F - FC Cu - FC CuAl - EF - ES - R - FC CuAl	F - FC Cu - FC CuAl - EF - ES - R - FC CuAl
withdrawable		-			-	-
Fixing on DIN rail		DIN EN 50022			DIN EN 50022	-
Mechanical life	[No. operations]	25000			25000	20000
	[No. Hourly operations]	240			240	120
Electrical life @ 415 V AC	[No. operations]	8000			8000	7000
	[No. Hourly operations]	120			120	60
Basic fixed version dimensions	W [mm]	90			105	140
	D [mm]	70			103.5	103.5
	H [mm]	130			150	205
Weight	fixed	1.1			1.5	2.35
	plug-in	-			-	3.6
	withdrawable	1.5			2.7	3.85

TERMINAL CAPTION  
 F = Front  
 EF = Front extended  
 ES = Front extended spread  
 FC Cu = Front for copper cables  
 R = Rear orientated  
 FC CuAl = Front for CuAl cables  
 MC = Multicable  
 HR = Rear flat horizontal  
 VR = Rear flat vertical  
 HR/VR = Rear flat orientated

<sup>(1)</sup> 75% for T5 630  
<sup>(2)</sup> 50% for T5 630  
<sup>(3)</sup> Icw = 5 kA  
<sup>(4)</sup> Icw = 10 kA  
<sup>(5)</sup> Icw = 20 kA (S, H, L version) - 15 A (V version)  
**Notes:** in the plug-in version of T2, T3, T5 630 and in the withdrawable version of T5 630 the maximum rated current available is derated by 10% at 40 °C

### 3 General characteristics

	Tmax T4					Tmax T5					Tmax T6				Tmax T7			
Rated uninterrupted current, <b>Iu</b>	250, 320					400, 630					630, 800				800/1000/1250			
Rated service current, <b>In</b>	10...320					320, 400, 630					630				-			
Poles	3					3					3				3			
Rated service current, <b>Iue</b>	(AC) 690 (DC) 750					690 750					690 750				690 -			
Rated impulse withstand voltage, <b>Uimp</b>	8					8					8				8			
Rated insulation voltage, <b>Ui</b>	1000					1000					1000				1000			
Test voltage at industrial frequency for 1 min.	3500					3500					3500				3500			
Rated ultimate short-circuit breaking capacity, <b>Icu</b>	<b>N</b>	<b>S</b>	<b>H</b>	<b>L</b>	<b>V</b>	<b>N</b>	<b>S</b>	<b>H</b>	<b>L</b>	<b>V</b>	<b>N</b>	<b>S</b>	<b>H</b>	<b>L</b>	<b>S</b>	<b>H</b>	<b>L</b>	<b>V</b>
(AC) 50-60 Hz 220/230 V	70	85	100	200	200	70	85	100	200	200	70	85	100	200	85	100	200	200
(AC) 50-60 Hz 380/415 V	36	50	70	120	200	36	50	70	120	200	36	50	70	100	50	70	120	150
(AC) 50-60 Hz 440 V	30	40	65	100	180	30	40	65	100	180	30	45	50	80	50	65	100	130
(AC) 50-60 Hz 500 V	25	30	50	85	150	25	30	50	85	150	25	35	50	65	40	50	85	100
(AC) 50-60 Hz 690 V	20	25	40	70	80	20	25	40	70	80	20	22	25	30	30	42	50	60
Rated service short-circuit breaking capacity, <b>Ics</b>																		
(AC) 50-60 Hz 220/230 V	100%	100%	100%	100%	100%	100%	100%	100%	100%	100%	100%	100%	100%	75%	100%	100%	100%	100%
(AC) 50-60 Hz 380/415 V	100%	100%	100%	100%	100%	100%	100%	100%	100%	100%	100%	100%	100%	75%	100%	100%	100%	100%
(AC) 50-60 Hz 440 V	100%	100%	100%	100%	100%	100%	100%	100%	100%	100%	100%	100%	100%	75%	100%	100%	100%	100%
(AC) 50-60 Hz 500 V	100%	100%	100%	100%	100%	100%	100%	100%	100%	100%	100%	100%	100%	75%	100%	100%	75%	100%
(AC) 50-60 Hz 690 V	100%	100%	100%	100%	100%	100%	100%	100%	100%	100%	75%	75%	75%	75%	100%	75%	75%	75%
Rated short-circuit making capacity, <b>Icm</b>																		
(AC) 50-60 Hz 220/230 V	154	187	220	440	660	154	187	220	440	660	154	187	220	440	187	220	440	440
(AC) 50-60 Hz 380/415 V	75.6	105	154	264	440	75.6	105	154	264	440	75.6	105	154	220	105	154	264	330
(AC) 50-60 Hz 440 V	63	84	143	220	396	63	84	143	220	396	63	94.5	105	176	105	143	220	286
(AC) 50-60 Hz 500 V	52.5	63	105	187	330	52.5	63	105	187	330	52.5	73.5	105	143	84	105	187	220
(AC) 50-60 Hz 690 V	40	52.5	84	154	176	40	52.5	84	154	176	40	48.4	55	66	63	88.2	105	132
Opening time (415 V)															15	10	8	8
Utilisation category (IEC 60947-2)	A					B (400 A) <sup>(3)</sup> - A (630 A)					B <sup>(3)</sup>				B <sup>(3)</sup>			
Isolation behaviour	■					■					■				■			
Reference Standard	IEC 60947-2/IEC 60947-4					IEC 60947-2/IEC 60947-4					IEC 60947-2/IEC 60947-4				IEC 60947-2			
Protection against short-circuit	■					■					■				■			
Magnetic only trip unit	-					-					-				-			
Electronic trip unit	■					■					■				■			
Integrated protection (IEC 60947-4-1)	■					■					■				■			
Electronic trip unit	■					■					■				■			
Interchangeability	■					■					■				■			
Versions	F - P - W					F - P - W					F - W				F-W			
Terminals	fixed	F - FC Cu - FC CuAl - EF - ES - R - MC				F - FC Cu - FC CuAl - EF - ES - R - MC	F - FC Cu - FC CuAl - EF - ES - R				F - FC CuAl - EF - ES - R - RC	F-EF-ES-FC CuAl-HR/VR						
plug-in		EF - ES - R - FC Cu - FC CuAl				EF - ES - R - FC Cu - FC CuAl	EF - ES - R - FC Cu - FC CuAl				-	-						
withdrawable		EF - ES - R - FC Cu - FC CuAl				EF - ES - R - FC Cu - FC CuAl	EF - ES - R - FC Cu - FC CuAl				EF - HR - VR	F-HR/VR						
Fixing on DIN rail		-				-	-				-	-						
Mechanical life	[No. operations]	20000				25000	20000				20000	10000						
	[No. Hourly operations]	240				240	120				120	60						
Electrical life @ 415 V AC	[No. operations]	8000				8000	7000				5000	2000 (S+H versions) - 3000 (V version)						
	[No. Hourly operations]	120				120	60				60	60						
Basic fixed version dimensions	W [mm]	105				105	140				210	210						
	D [mm]	103.5				103.5	103.5				103.5	154 (manual) / 178 (motorizable)						
	H [mm]	205				205	205				268	268						
Weight	fixed	2.35				3.6	3.25				9.5/12	9.7/12.5 (manual) - 11/14 (motorizable)						
	plug-in	-				-	-				-	-						
	withdrawable	3.85				5.4	5.4				12.1/15.1	29.7/39.6 (manual) - 32/42.6 (motorizable)						

### 3 General characteristics

#### SACE Isomax moulded-case circuit-breakers for motor protection

Rated uninterrupted, I <sub>u</sub>	[A]
Rated current, I <sub>n</sub>	[A]
Poles	No
Rated operational voltage (ac) 50-60 Hz, U <sub>e</sub>	[V]
Rated impulse withstand voltage, U <sub>imp</sub>	[kV]
Rated insulation voltage, U <sub>i</sub>	[V]
Test voltage at industrial frequency for 1 minute	[V]
Rated ultimate short-circuit braking capacity, I <sub>cu</sub>	
(ac) 50-60Hz 220/230V	[kA]
(ac) 50-60Hz 380/415V	[kA]
(ac) 50-60Hz 440V	[kA]
(ac) 50-60Hz 500V	[kA]
(ac) 50-60Hz 690V	[kA]
Rated service short-circuit braking capacity, I <sub>cs</sub>	[%I <sub>cu</sub> ]
Rated short-circuit making capacity (415Vac), I <sub>cm</sub>	[kA]
Opening time (415Vac at I <sub>cu</sub> )	[ms]
Utilization category (EN 60947-2)	
Insulation behaviour	
Reference standard	
IEC 60947-2, EN60947-2	
IEC 60947-4-1, EN60947-4-1	
Microprocessor-based release	
Interchangeability	
Versions	
Terminals	
Fixed	
Plug-in	
Withdrawable	
Mechanical life	[No. of operations]
	[Operations per hour]
	L [mm]
	D [mm]
Basic dimensions, fixed 3 poles	H [mm]
	3 poles fixed [kg]
	3 poles plug-in [kg]
Weight	3 poles withdrawable [kg]

## KEY TO VERSIONS

F = Fixed

P = Plug-in

W = Withdrawable

## KEY TO TERMINALS

F = Front

EF = Extended front

ES = Extended spreaded front

FC CuAl = Front for copper or aluminium cables  
R = Rear threaded

### 3 General characteristics

S7			S7	
1250 / 1600			1250	
1000, 1250 / 1600			1000	
3			3	
690			690	
8			8	
8000			8000	
3000			3000	
S	H	L	S	H
85	100	200	85	100
50	65	100	50	65
40	55	80	40	55
35	45	70	35	45
20	25	35	20	25
100%	75%	50%	100%	75%
105	143	220	105	143
22	22	22	22	22
B			B	
■			■	
-			-	
PR211/P (I)			PR212/MP (L-R-I-U)	
■			■	
F - W			F - W	
F - EF - ES - FCCuAl (1250A) - HR - VR			F - EF - ES - FCCuAl - HR - VR	
-			-	
EF - HR - VR			EF - HR - VR	
10000			10000	
120			120	
210			210	
138.5			138.5	
406			406	
17			17	
-			-	
21.8			21.8	

RC = Rear for copper or aluminium cables

HR = Rear horizontal flat bar

VR = Rear vertical flat bar

### 3 General characteristics

#### SACE Emax air circuit-breakers

Common data

Voltages		
Rated operational voltage Ue	[V]	690 -
Rated insulation voltage Ui	[V]	1000
Rated impulse withstand voltage Uimp	[kV]	12
Service temperature		
	[°C]	-25...+70
Storage temperature		
	[°C]	-40...+70
Frequency f	[Hz]	50 - 60
Number of poles		3 - 4
Version		Fixed -Withdrawable

Performance levels		
Currents: rated uninterrupted current (at 40 °C) Iu		
	[A]	
	[A]	
	[A]	
	[A]	
	[A]	
	[A]	
Neutral pole current-carrying capacity for 3-pole CBs	[%Iu]	
Rated ultimate breaking capacity under short-circuit Icu		
220/230/380/400/415 V -	[kA]	
440 V -	[kA]	
500/525 V -	[kA]	
660/690 V -	[kA]	
Rated service breaking capacity under short-circuit Ics		
220/230/380/400/415 V -	[kA]	
440 V -	[kA]	
500/525 V -	[kA]	
660/690 V -	[kA]	
Rated short-time withstand current Icw		
	(1s) [kA]	
	(3s) [kA]	
Rated making capacity under short-circuit (peak value) Icm		
220/230/380/400/415 V -	[kA]	
440 V -	[kA]	
500/525 V -	[kA]	
660/690 V -	[kA]	
Utilisation category (according to CEI EN 60947-2)		
Isolation behaviour (according to CEI EN 60947-2)		
Overcurrent protection		
Electronic releases for AC applications		
Operating times		
Closing time (max)	[ms]	
Breaking time for I<Icw (max) <sup>(1)</sup>	[ms]	
Breaking time for I>Icw (max)	[ms]	
Overall dimensions		
F xed: H = 418 mm - D = 302 mm L (3/4 poles)	[mm]	
W thdrawable: H = 461 mm - D = 396.5 mm L (3/4 poles)	[mm]	
Weights (circuit-breaker complete with releases and CTs, including accessories)		
Fixed 3/4 poles	[kg]	
W thdrawable 3/4 poles (including fixed part)	[kg]	

(1) Without intentional delays  
 (2) Performance at 600 V is 100 kA

SACE Emax air circuit-breakers

	X1	E1 B-N					
Rated uninterrupted current (at 40 °C) Iu	[A]	800	1250	1600	800	1000-1250	1600
Mechanical life with regular ordinary maintenance	[No. operations x 1000]	12.5	12.5	12.5	25	25	25
Operation frequency	[Operations/hour]	60	60	60	60	60	60
Electrical life	(440 V -) [No. operations x 1000]	6	4	3	10	10	10
	(690 V -) [No. operations x 1000]	3	2	1	10	8	8
Operation frequency	[Operations/hour]	30	30	30	30	30	30

### 3 General characteristics

X1			E1			E2			E3			E4			E6				
B	N	L	B	N	L	B	N	S	L	N	S	H	V	L	S	H	V	H	V
630	630	630	800	800		1600	1000	800	1250	2500	1000	800	800	2000	4000	3200	3200	4000	3200
800	800	800	1000	1000		2000	1250	1000	1600	3200	1250	1000	1250	2500	4000	4000	5000	4000	
1000	1000	1000	1250	1250		1600	1250			1600	1250	1600					6300	5000	
1250	1250	1250	1600	1600		2000	1600			2000	1600	2000							6300
1600	1600					2000				2500	2000	2500							
										3200	2500	3200							
										3200									
100	100	100	100	100		100	100	100	100	100	100	100	100	100	50	50	50	50	50
42	65	150	42	50		42	65	85	130	65	75	100	130	130	75	100	150	100	150
42	65	130	42	50		42	65	85	110	65	75	100	130	110	75	100	150	100	150
42	50	100	42	50		42	55	65	85	65	75	100	100	85	75	100	130	100	130
42	50	60	42	50		42	55	65	85	65	75	85 <sup>(2)</sup>	100	85	75	85 <sup>(2)</sup>	100	100	100
42	50	150	42	50		42	65	85	130	65	75	85	100	130	75	100	125	100	125
42	50	130	42	50		42	65	85	110	65	75	85	100	110	75	100	125	100	125
42	42	100	42	50		42	55	65	65	65	75	85	85	65	75	100	130	100	100
42	42	45	42	50		42	55	65	65	65	75	85	85	65	75	85	100	100	100
42	42	15	42	50		42	55	65	10	65	75	75	85	15	75	100	100	100	100
			36	36		42	42	42	-	65	65	65	65	-	75	75	75	85	85
88.2	143	330	88.2	105		88.2	143	187	286	143	165	220	286	286	165	220	330	220	330
88.2	143	286	88.2	105		88.2	143	187	242	143	165	220	286	242	165	220	330	220	330
88.2	121	220	75.6	75.6		84	121	143	187	143	165	187	220	187	165	220	286	220	286
88.2	121	132	75.6	75.6		84	121	143	187	143	165	187	220	187	165	187	220	220	220
B	B	A	B	B		B	B	B	A	B	B	B	B	A	B	B	B	B	B
■	■	■	■	■		■	■	■	■	■	■	■	■	■	■	■	■	■	■
■	■	■	■	■		■	■	■	■	■	■	■	■	■	■	■	■	■	■
80	80	80	80	80		80	80	80	80	80	80	80	80	80	80	80	80	80	80
70	70	70	70	70		70	70	70	70	70	70	70	70	70	70	70	70	70	70
30	30	12	30	30		30	30	30	12	30	30	30	12	30	30	30	30	30	
210/280			296/386			296/386				404/530					566/656			782/908	
284/364			324/414			324/414				432/558					594/684			810/936	
11/14			45/54	45/54		50/61	50/61	50/61	52/63	66/80	66/80	66/80	66/80	72/83	97/117	97/117	97/117	140/160	140/160
32/42.6			70/82	70/82		78/93	78/93	78/93	80/95	104/125	104/125	104/125	104/125	110/127	147/165	147/165	147/165	210/260	210/240

E2 B-N-S			E2 L		E3 N-S-H-V			E3 L		E4 S-H-V		E6 H-V							
800	1000-1250	1600	2000	1250	1600	800	1000-1250	1600	2000	2500	3200	2000	2500	3200	4000	3200	4000	5000	6300
25	25	25	25	20	20	20	20	20	20	20	20	15	15	15	15	12	12	12	12
60	60	60	60	60	60	60	60	60	60	60	60	60	60	60	60	60	60	60	60
15	15	12	10	4	3	12	12	10	9	8	6	2	1.8	7	5	5	4	3	2
15	15	10	8	3	2	12	12	10	9	7	5	1.5	1.3	7	4	5	4	2	1.5
30	30	30	30	20	20	20	20	20	20	20	20	20	20	10	10	10	10	10	10

### 3 General characteristics

#### SACE Emax air circuit-breakers with full-size neutral conductor

		E4S/f	E4H/f	E6H/f
Rated uninterrupted current (at 40 °C) $I_u$	[A]	4000	3200	4000
	[A]		4000	5000
				6300
Number of poles		4	4	4
Rated operational voltage $U_e$	[V ~]	690	690	690
Rated ultimate short-circuit breaking capacity $I_{cu}$				
220/230/380/400/415 V ~	[kA]	80	100	100
440 V ~	[kA]	80	100	100
500/525 V ~	[kA]	75	100	100
660/690 V ~	[kA]	75	100	100
Rated service short-circuit breaking capacity $I_{cs}$				
220/230/380/400/415 V ~	[kA]	80	100	100
440 V ~	[kA]	80	100	100
500/525 V ~	[kA]	75	100	100
660/690 V ~	[kA]	75	100	100
Rated short-time withstand current $I_{cw}$				
(1s)	[kA]	75	85	100
(3s)	[kA]	75	75	85
Rated short-circuit making capacity $I_{cm}$				
220/230/380/400/415 V ~	[kA]	176	220	220
440 V ~	[kA]	176	220	220
500/525 V ~	[kA]	165	220	220
660/690 V ~	[kA]	165	220	220
Utilization category (in accordance with IEC 60947-2)		B	B	B
Isolation behavior (in accordance with IEC 60947-2)		■	■	■
<b>Overall dimensions</b>				
Fixed: H = 418 mm - D = 302 mm L	[mm]	746	746	1034
Withdrawable: H = 461 - D = 396.5 mm L	[mm]	774	774	1062
<b>Weight</b> (circuit-breaker complete with releases and CT, not including accessories)				
Fixed	[kg]	120	120	165
Withdrawable (including fixed part)	[kg]	170	170	250

### 3 General characteristics

#### 3.2 Trip curves

##### 3.2.1 Trip curves of thermomagnetic and magnetic only releases

The overload protection function must not trip the breaker in 2 hours for current values which are lower than 1.05 times the set current, and must trip within 1.3 times the set current. By "cold trip conditions", it is meant that the overload occurs when the circuit-breaker has not reached normal working temperature (no current flows through the circuit-breaker before the anomalous condition occurs); on the contrary "hot trip conditions" refer to the circuit-breaker having reached the normal working temperature with the rated current flowing through, before the overload current occurs. For this reason "cold trip conditions" times are always greater than "hot trip conditions" times.

The protection function against short-circuit is represented in the time-current curve by a vertical line, corresponding to the rated value of the trip threshold  $I_3$ . In accordance with the Standard IEC 60947-2, the real value of this threshold is within the range 0.8- $I_3$  and 1.2- $I_3$ . The trip time of this protection varies according to the electrical characteristics of the fault and the presence of other devices; it is not possible to represent the envelope of all the possible situations in a sufficiently clear way in this curve; therefore it is better to use a single straight line, parallel to the current axis. All the information relevant to this trip area and useful for the sizing and coordination of the plant are represented in the limitation curve and in the curves for the specific let-through energy of the circuit-breaker under short-circuit conditions.

### 3 General characteristics

Trip curve  
thermomagnetic  
release

**T1 160**

**TMD**

$I_n = 16 \div 63 \text{ A}$

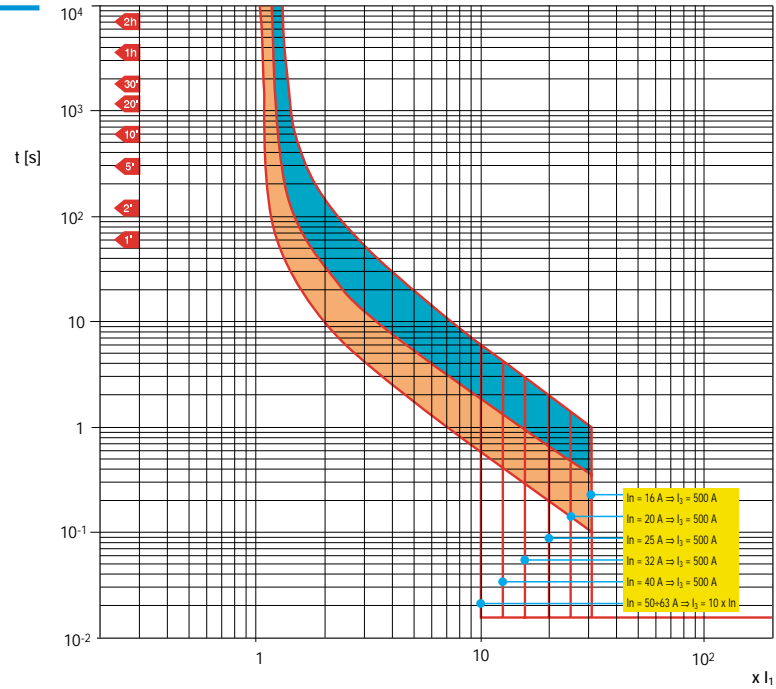

### 3 General characteristics

Trip curve  
thermomagnetic  
release

**T1 160**

**TMD**

$I_n = 16 \div 63 \text{ A}$

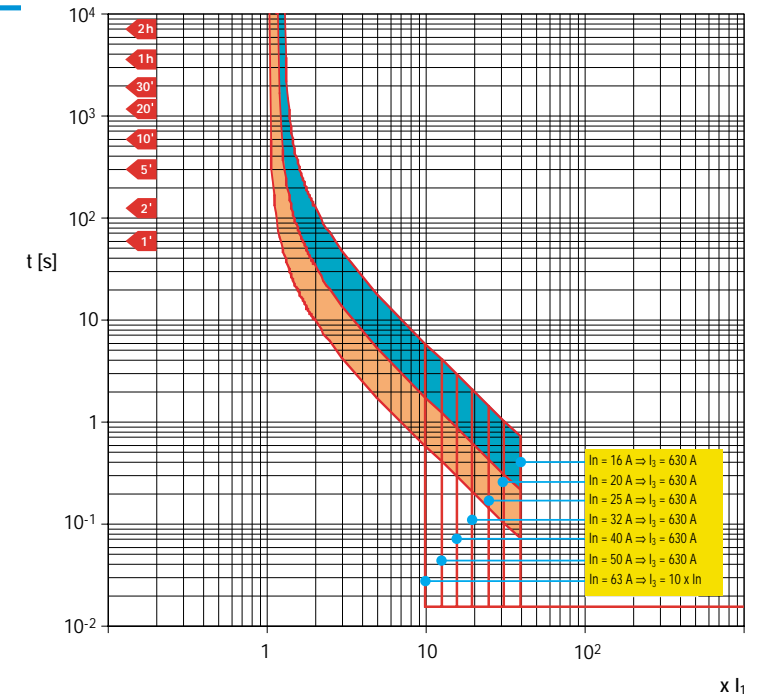

### 3 General characteristics

Trip curve  
thermomagnetic  
release

**T1 160**

**TMD**

$I_n = 80 \div 160 \text{ A}$

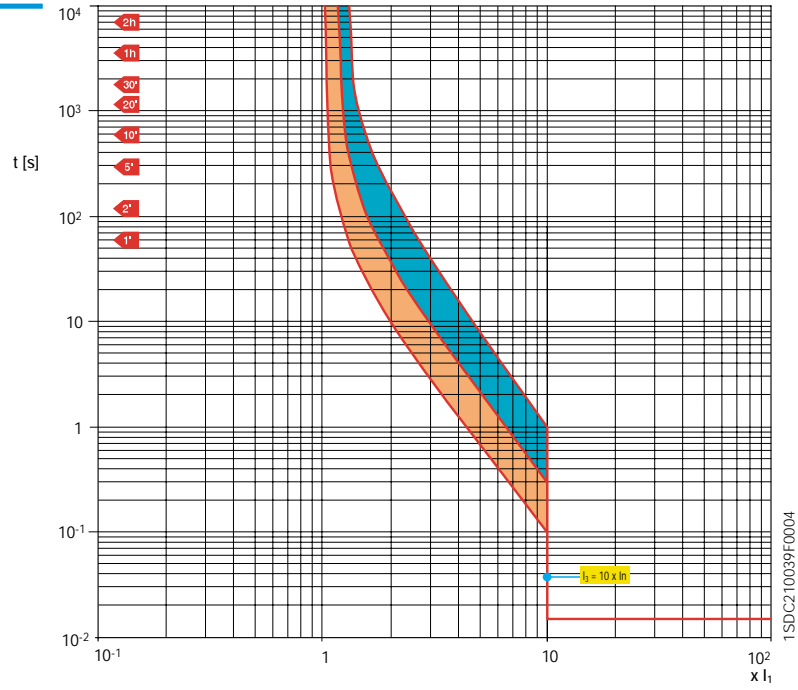

### 3 General characteristics

Trip curve  
thermomagnetic  
release

**T2 160**

**TMD**

$I_n = 1.6 \div 100 \text{ A}$

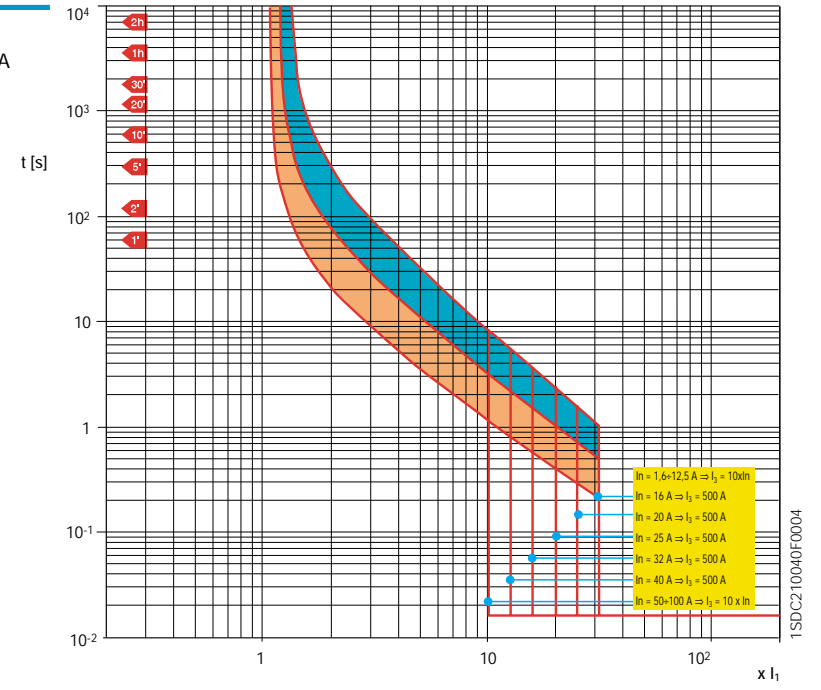

### 3 General characteristics

Trip curve  
thermomagnetic  
release

**T2 160**

**TMD**

$I_n = 125 \div 160 \text{ A}$

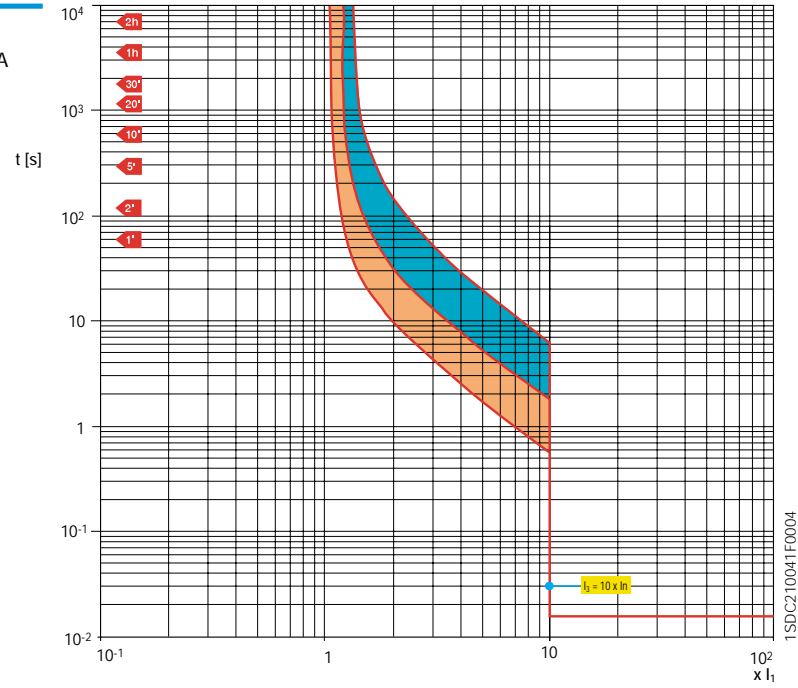

### 3 General characteristics

Trip curve  
thermomagnetic  
release

**T2 160**

**TMG**

$I_n = 16 \div 160 \text{ A}$

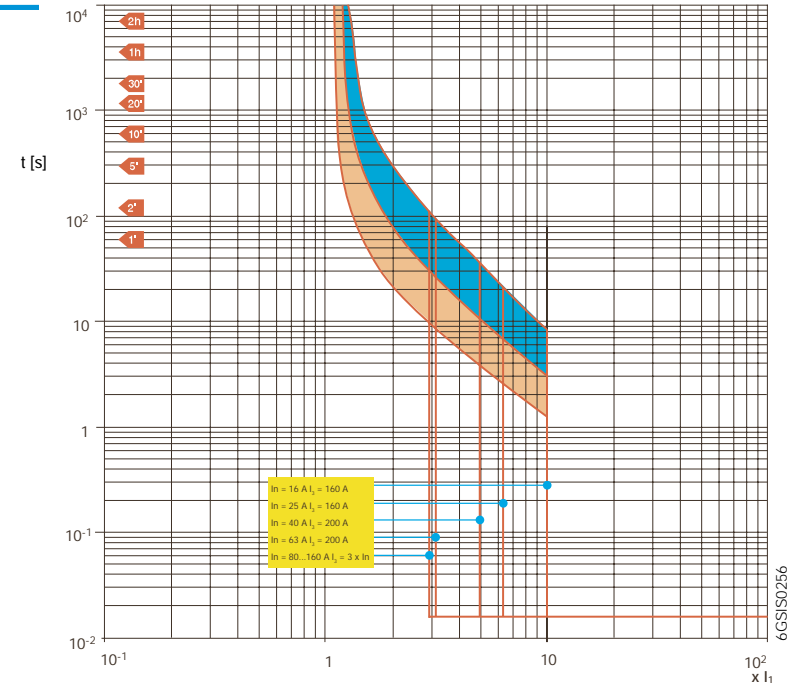

### 3 General characteristics

Trip curve  
thermomagnetic  
release  
**T3 250**  
**TMD**

$I_n = 63 \div 250 \text{ A}$

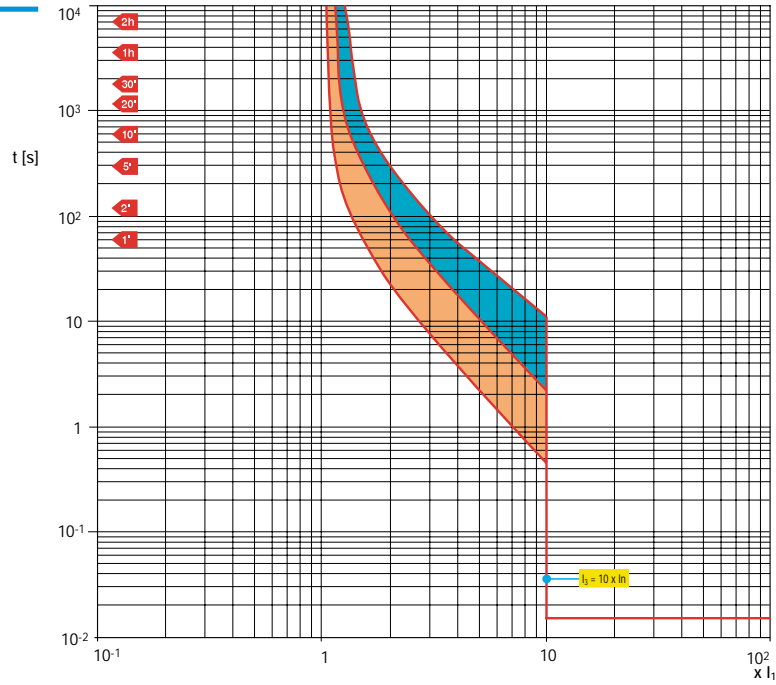

### 3 General characteristics

Trip curve  
thermomagnetic  
release  
**T3 250**  
**TMG**

$I_n = 63 \div 250 \text{ A}$

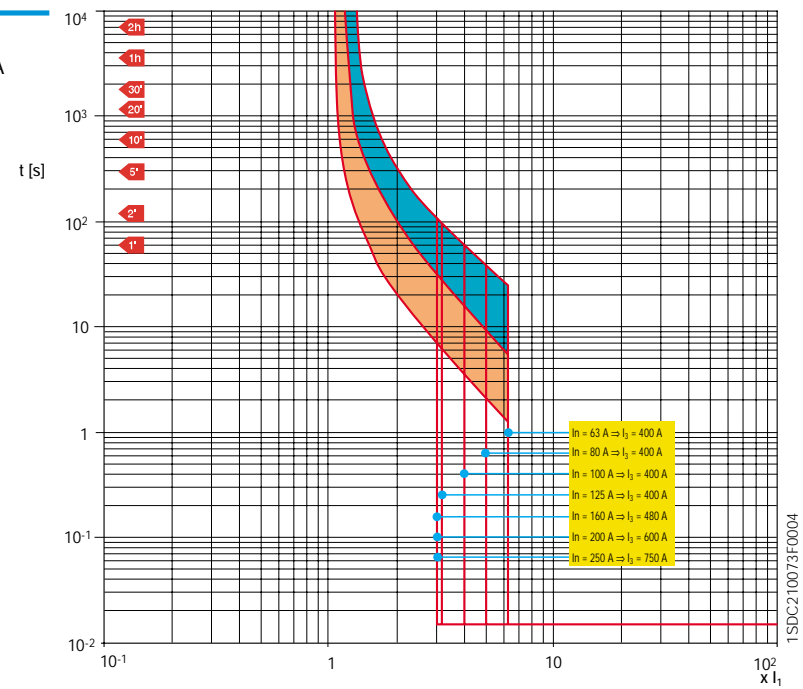

1SDC210073F0004



### 3 General characteristics

Trip curve  
thermomagnetic  
release  
**T4 250**  
**TMD**

$I_n = 20 \div 50 \text{ A}$

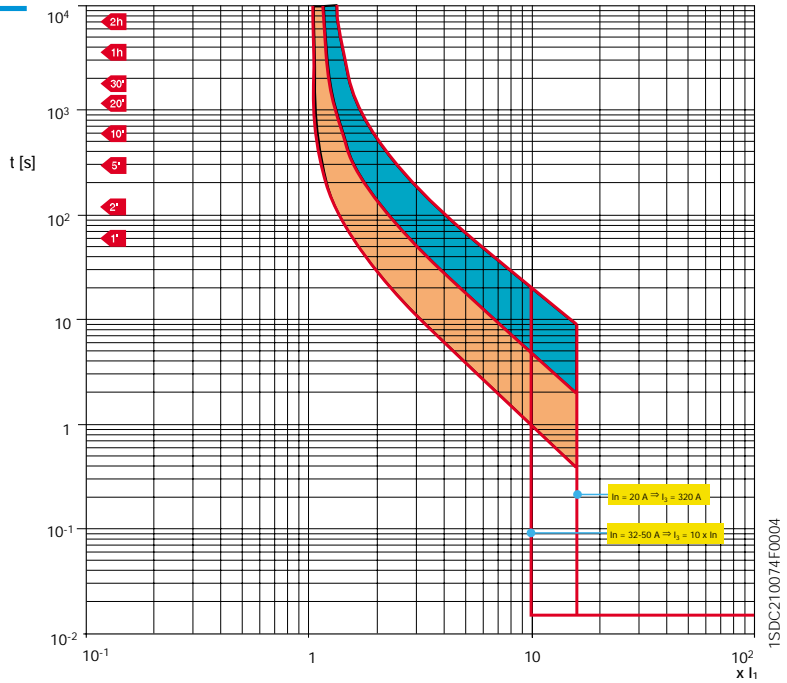

1SDC210074F0004

### 3 General characteristics

Trip curve  
thermomagnetic  
release  
**T4 250/320**  
**TMA**

$I_n = 80 \div 250 \text{ A}$

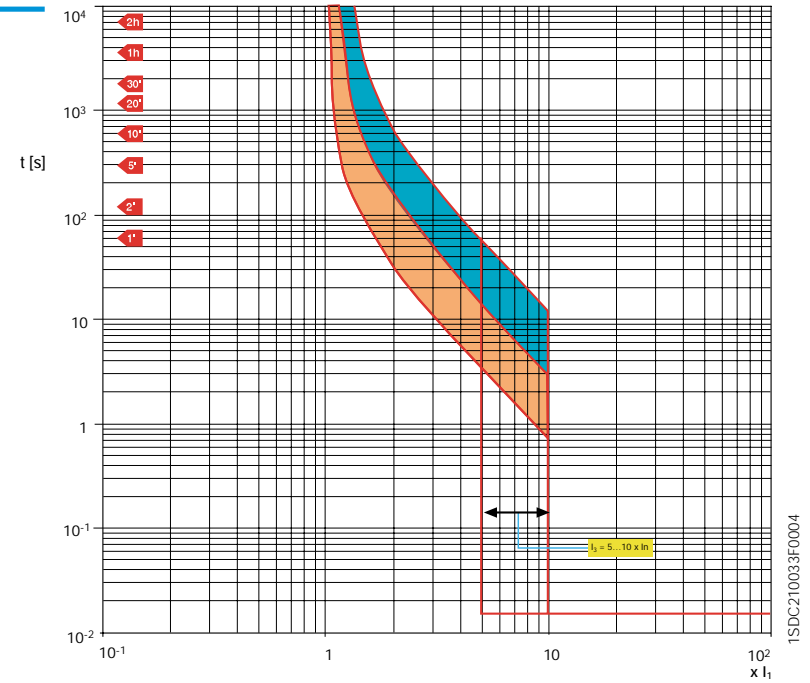

1SDC210033F0004

### 3 General characteristics

Trip curve  
thermomagnetic  
release

**T5 400/630**

**TMA**

$I_n = 320+500 \text{ A}$

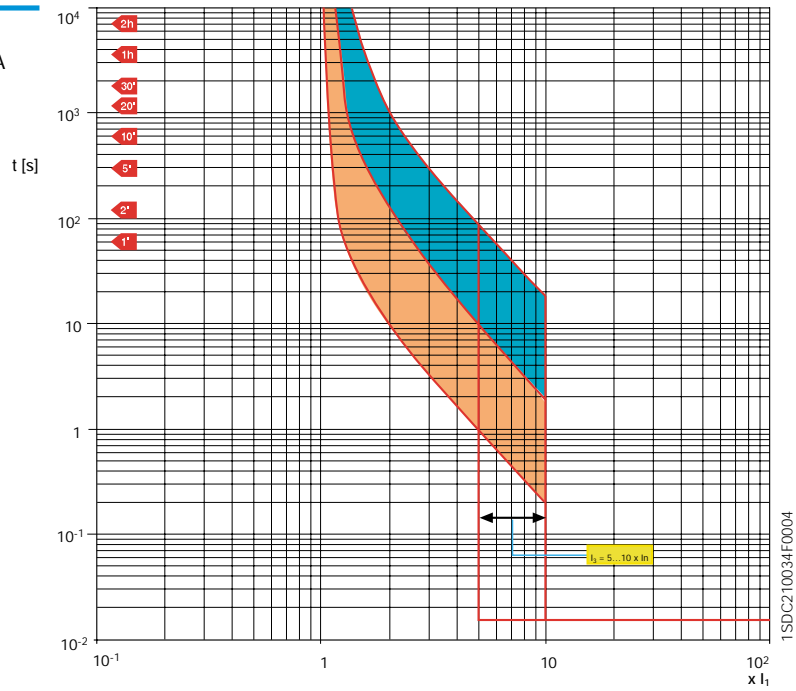

### 3 General characteristics

Trip curve  
thermomagnetic  
release

**T5 400/630**

**TMG**

$I_n = 320+500 \text{ A}$

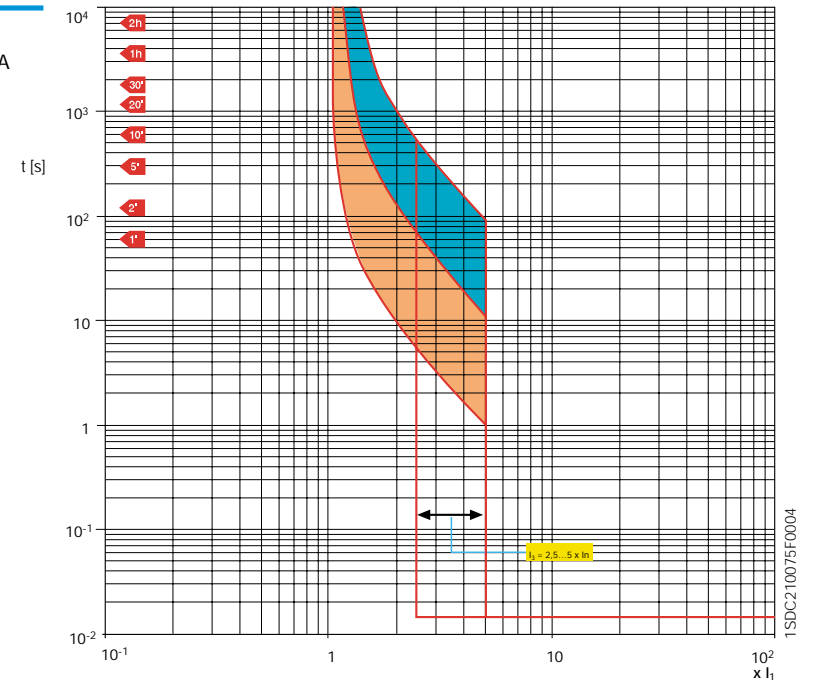

### 3 General characteristics

Trip curve  
thermomagnetic  
release

**T6 630**

**TMA**

$I_n = 630 \text{ A}$

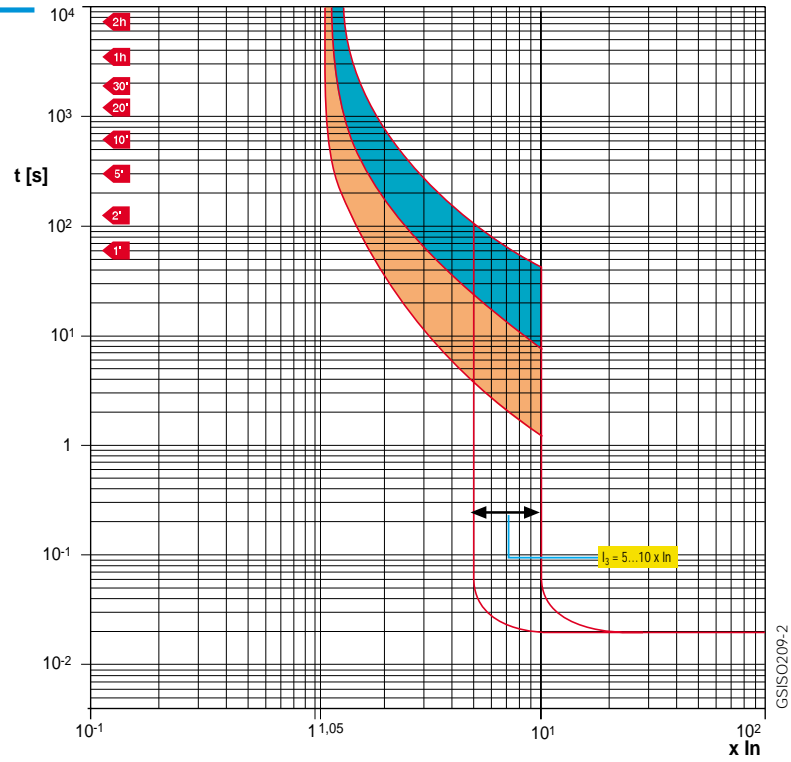

### 3 General characteristics

Trip curve  
thermomagnetic  
release

**T6 800**

**TMA**

$I_n = 800 \text{ A}$

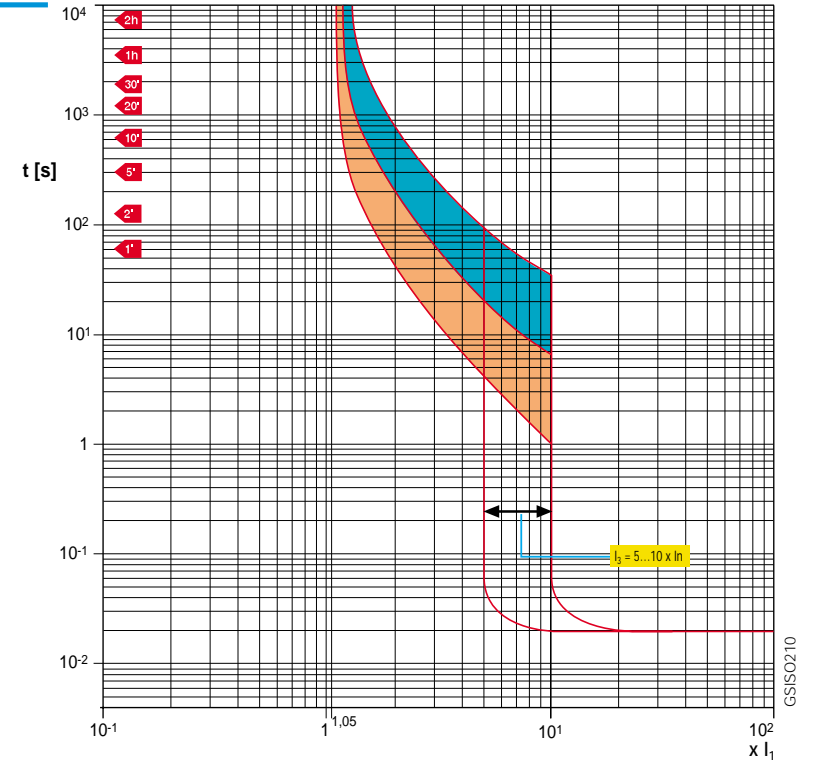

### 3 General characteristics

Trip curve  
thermomagnetic  
release

**T2 160**

**MF**

$$I_3 = 13 \times I_n$$

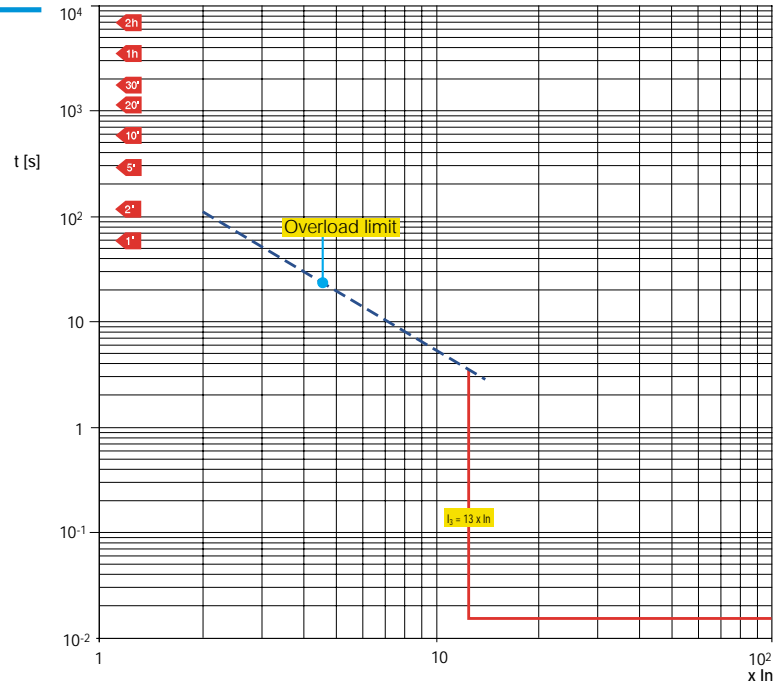

### 3 General characteristics

Trip curve  
thermomagnetic  
release

**T2 160/T3 250**

**MA**

$$I_3 = 6 \dots 12 \times I_n$$

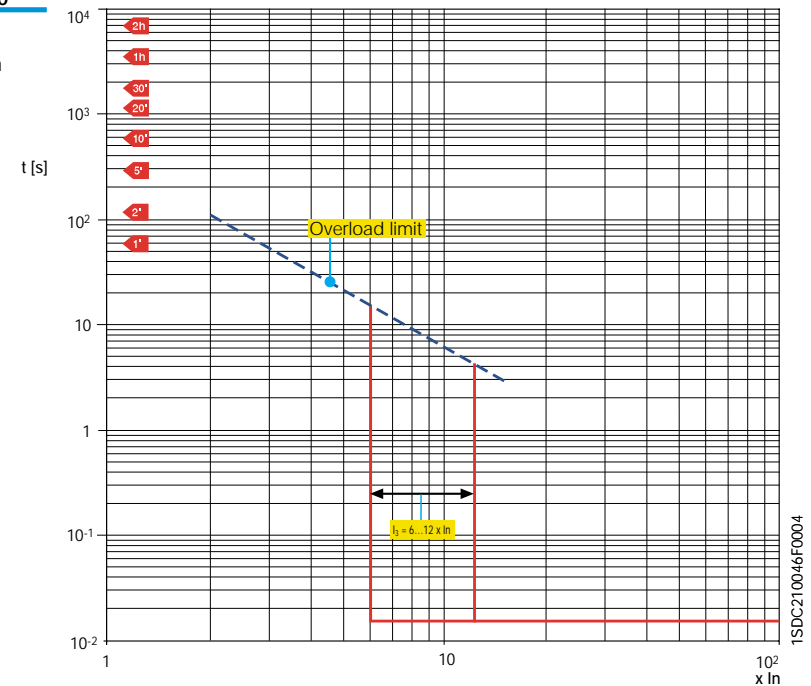

### 3 General characteristics

Trip curve  
thermomagnetic  
release

**T4 250**

**MA**

$$I_3 = 6 \dots 14 \times I_n$$

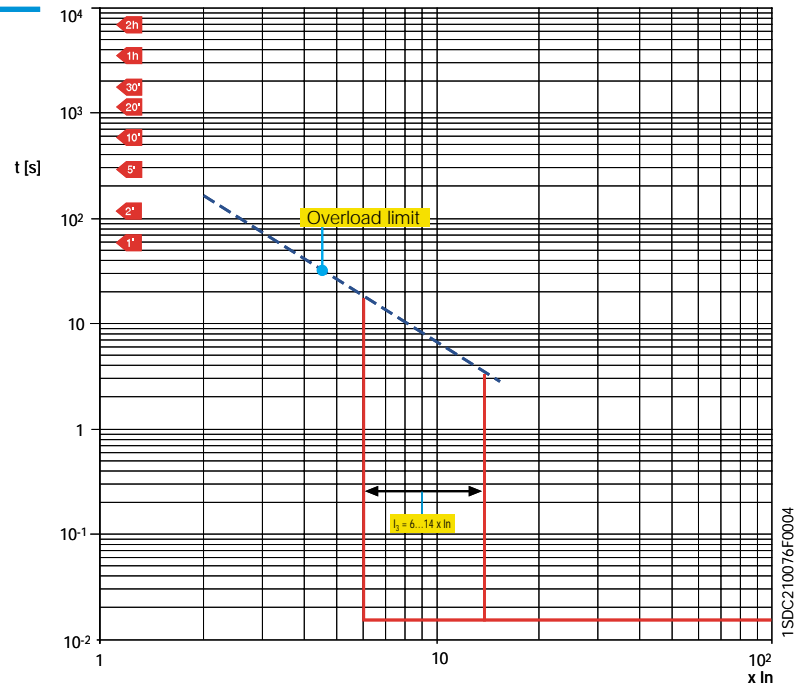

1SDC210076F0004

### 3 General characteristics

#### Example of thermomagnetic release setting

Consider a circuit-breaker type T1 160 In 160 and select, using the trimmer for thermal regulation, the current threshold, for example at 144 A; the magnetic trip threshold, fixed at 10·In, is equal to 1600 A.

Note that, according to the conditions under which the overload occurs, that is either with the circuit-breaker at full working temperature or not, the trip of the thermal release varies considerably. For example, for an overload current of 600 A, the trip time is between 1.2 and 3.8 s for hot trip, and between 3.8 and 14.8 s for cold trip.

For fault current values higher than 1600 A, the circuit-breaker trips instantaneously through magnetic protection.

#### T1 160 - In 160 Time-Current curves

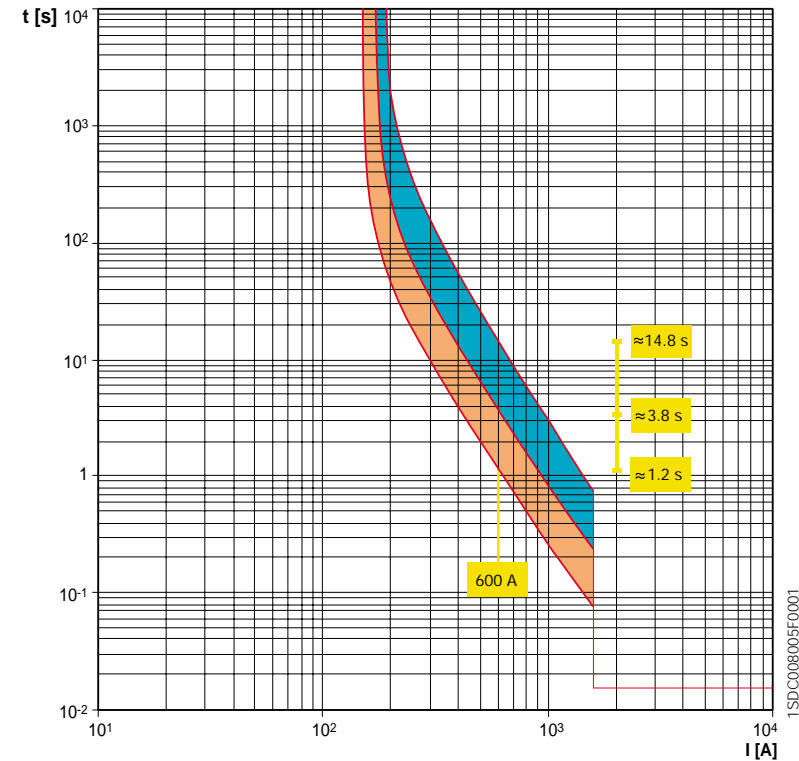

1SDC008005F0001

### 3 General characteristics

#### 3.2.2 Trip curves of electronic releases

##### Introduction

The following figures show the curves of the single protection functions available in the electronic releases. The setting ranges and resolution are referred to setting operations to be carried out locally.

##### LFUNCTION(overload protection)

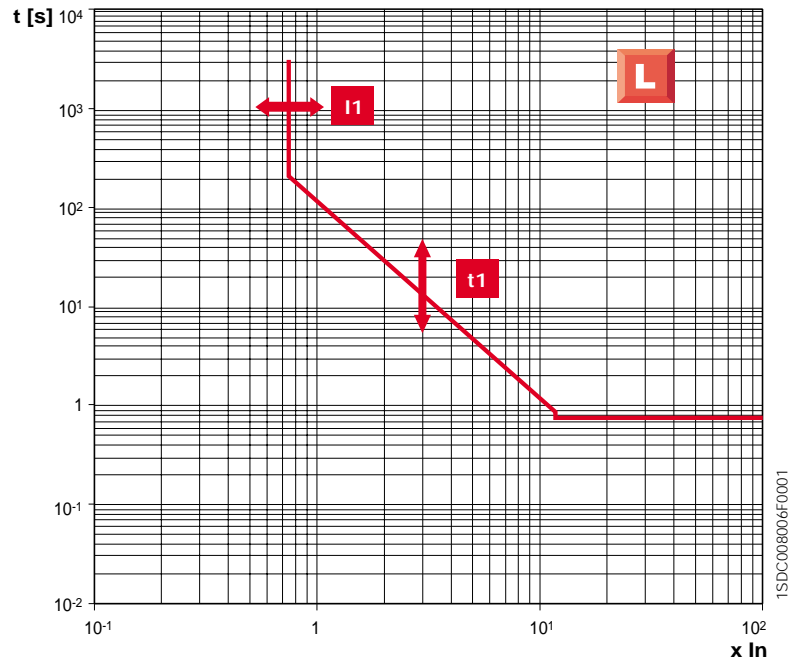

### 3 General characteristics

	I1	t1
PR221		3s-6s (@6xI1) for T2 and 12s for T4-T5-T6
PR231	(0.4...1) x In with step 0.04 x In	3s-12s (@6xI1)
PR232		3s-6s-12s-18s (@6xI1)
PR222	(0.4...1) x In with step 0.02 x In	3s-6s-9s-18s <sup>(1)</sup> (@6xI1)
PR223	(0.18...1) x In with step 0.01 x In	3...18s with step 0.5 <sup>(2)</sup>
PR211	(0.4-0.5-0.6-0.7-0.8-0.9-0.95-1) x In	
PR212	(0.4-0.5-0.55-0.6-0.65-0.7-0.75-0.8-0.85-0.875-0.9-0.925-0.95-0.975-1)	A=3s;B=6s;C=12s;D=18s (@6xI1)
PR331	(0.4...1) x In with step 0.025 x In	3s-12s-24s-36s-48s-72s-108s-144s (@3xI1)
PR121		
PR332		
PR333		
PR122	(0.4...1) x In with step 0.01 x In	3...144s with step 3s (@3xI1)
PR123		

<sup>(1)</sup> for T4 In=320 A and T5 In=630A t1=12s

Here below the tolerances:

	I1	t1
PR221	1.05÷1.3 xI1	
PR211	1.1÷1.3 xI1 (for T4-T5-T6)	
PR212		± 10% (up to 6xIn) (up to 2x for T2) ± 20% (over 6xIn) (over 2xIn for T2)
PR331	1.05÷1.2 xI1	
PR332		
PR121	1.05÷1.2 xI1	± 10% (up to 4xIn) ± 20% (over 4xIn)
PR122		
PR123		
PR222		
PR223	1.1÷1.3 xI1	± 10%
PR231		
PR232		

<sup>(2)</sup> for T4-T5-T6

### 3 General characteristics

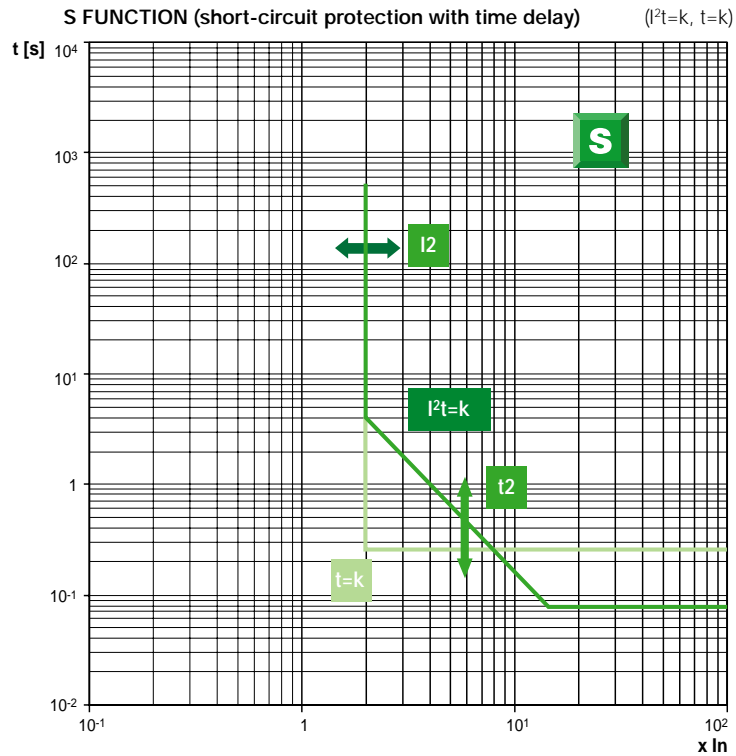

### 3 General characteristics

	<b>I2</b>	<b>t2</b>
PR221	(1-1.5-2-2.5-3-3.5-4-5-5.5-6-6.5-7-7.5-8-8.5-9-10) xIn	0.1s-0.25s (@8xIn with $I^2t=k$ )
PR231	(1-1.5-2-2.5-3-3.5-4-5-5.5-6-6.5-7-7.5-8-8.5-9-10) xIn	0.1s-0.25s (@10xIn with $I^2t=k$ )
PR232	(0.6-0.8-1.2-1.8-2.4-3-3.6-4.2-5-5.8-6.6-7.4-8-2-9-10) xIn	0.1s-0.25s-0.5s-0.8s (@10xIn with $I^2t=k$ )
PR222	(0.6-10) xIn with step 0.6 x In	0.05s-0.1s-0.25s-0.5s (@8xIn with $I^2t=k$ , and $t=k$ )
PR223	(0.6...10) x In with step 0.1 x In	0.05...0.5s step 0.01s (@8xIn with $I^2t=k$ , and $t=k$ )
PR211	(1-2-3-4-6-8-10) x In	A=0.05s;B=0.1s;C=0.25s;D=0.5s (@8xI2 with $I^2t=k$ , and $t=k$ )
PR212	(1-2-3-4-6-8-10) x In	
PR331	(0.6-0.8-1.2-1.8-2.4-3-3.6-4.2-5-5.8-6.6-7.4-8-2-9-10) xIn	0.1s...0.8s (@10xIn with $I^2t=k$ )
PR121	(1-1.5-2-2.5-3-3.5-4-5-6-7-8-8.5-9-9.5-10) xIn	0.1s...0.8s (@I>I2 with $t=k$ )
PR332		
PR333	(0.6...1) x In with step 0.1 x In	0.05...0.8s with step 0.01s (@10xIn with $I^2t=k$ ) 0.05...0.8s with step 0.01s (@I>I2xIn with $t=k$ )
PR122		
PR123		

Here below the tolerances:

	<b>I2</b>	<b>t2</b>
PR221	± 10% (T4-T5-T6) ± 10% (up to 2xIn) (T2) ± 20% (over 2xIn) (T2)	± 10% up to 6xIn (T4-T5-T6) ± 20% over to 6xIn (T4-T5-T6) ± 20% (T2)
PR222		
PR223	± 10%	± 10%
PR231		
PR232		
PR211		
PR212	± 10%	± 20%
PR331		
PR332		
PR121	± 7% (I <sub>g</sub> < 4xIn) ± 10% (I <sub>g</sub> > 4xIn)	± 15% (I <sub>g</sub> < 4xIn with $t=k$ ) ± 20% (I <sub>g</sub> > 4xIn with $t=k$ ) the best of the two data: ± 10% or 40ms (with $I^2t=k$ )
PR122		
PR123		
PR333	± 7% (I <sub>g</sub> < 6xIn) ± 10% (I <sub>g</sub> > 6xIn)	

### 3 General characteristics

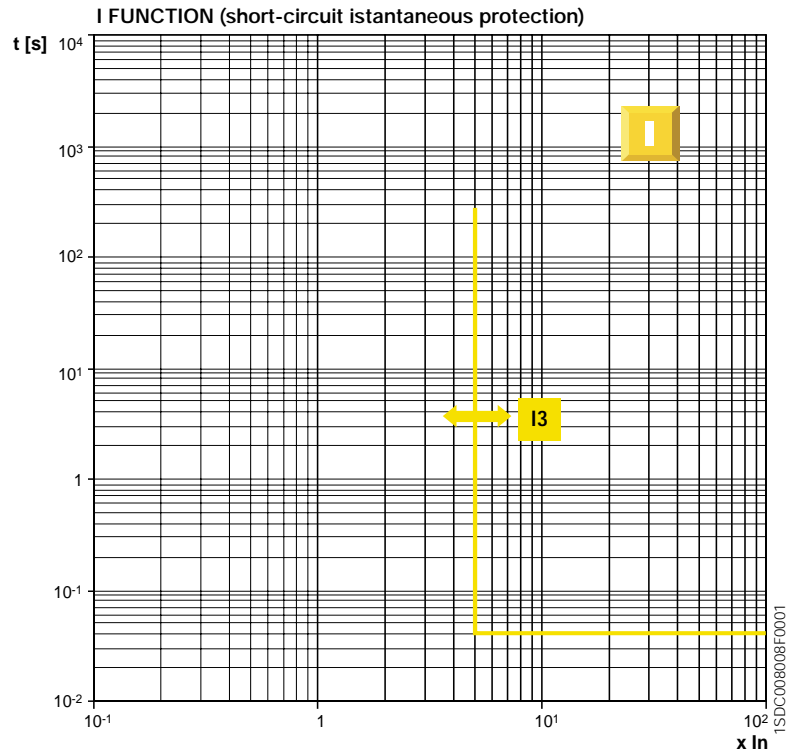

### 3 General characteristics

I3	
PR221	(1-1.5-2-2.5-3-3.5-4.5-5.5-6.5-7-7.5-8-8.5-9-10-12') x In
PR231	(1-1.5-2-2.5-3-3.5-4.5-5.5-6.5-7-7.5-8-8.5-9-10-12') x In
PR222	(1.5-2.5-3-4-4.5-5-5.5-6.5-7-7.5-8-9-9.5-10.5-12) x In
PR232	(1.5-2.5-3-4-4.5-5-5.5-6.5-7-7.5-8-9-9.5-10.5-12) x In
PR223	(1.5...12) x In with step 0.1 x In
PR211	(1.5-2-4-6-8-10-12) x In
PR212	(1.5-2-4-6-8-10-12) x In
PR331	(1.5-2-3-4-5-6-7-8-9-10-11-12-13-14-15) x In
PR121	(1.5-2-3-4-5-6-7-8-9-10-11-12-13-14-15) x In
PR332	(1.5-2-3-4-5-6-7-8-9-10-11-12-13-14-15) x In
PR333	(1.5...15) x In with step 0.1 x In
PR122	(1.5...15) x In with step 0.1 x In
PR123	(1.5...15) x In with step 0.1 x In

\*12xIn only for PR231/P

Here below the tolerances:

I3		Tripping time:
PR221	± 10% (T4-T5-T6)	< 25ms
	± 20% (T2)	< 25ms
PR211	± 20%	< 25ms
PR212	± 20%	< 25ms
PR222	± 10%	< 25ms
PR223	± 10%	< 25ms
PR231	± 10%	< 25ms
PR232	± 10%	< 25ms
PR331	± 10%	< 40ms
PR332	± 10%	< 40ms
PR333	± 10%	< 40ms
PR121	± 10%	< 30ms
PR122	± 10%	< 30ms
PR123	± 10%	< 30ms



### 3 General characteristics

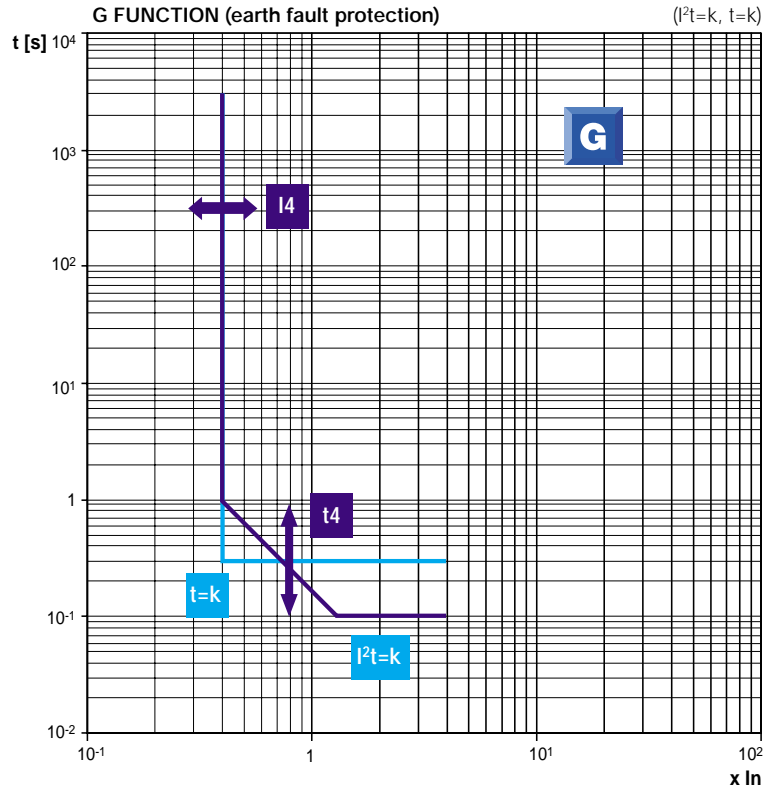

### 3 General characteristics

$I4$	$t4$
PR222 (0.2-0.25-0.45-0.55-0.75-0.8-1) xln	0.1s up to 3.15x I4; 0.2s up to 2.25x I4; 0.4s up to 1.6x I4; 0.8s up to 1.10x I4
PR223 (0.2...1) xln with step 0.1xln	0.1...0.8 xln with step 0.01s
PR212 (0.2-0.3-0.4-0.6-0.8-0.9-1) xln	A=0.1s; B=0.2s; C=0.4s; D=0.8s (@ 4x I4)
PR331 (0.2-0.3-0.4-0.6-0.8-0.9-1) xln	0.1s up to 4.47 x I4; 0.2s up to 3.16 x I4; 0.4s up to 2.24x I4; 0.80s up to 1.58x I4 ( $I^2t=k$ )
PR121 (0.2-0.3-0.4-0.6-0.8-0.9-1) xln	0.1s-0.2s-0.4s-0.80s (with $t=k$ )
PR122 (0.2-0.3-0.4-0.6-0.8-0.9-1) xln	0.1-0.2-0.4-0.8 s (@I=4xln with $I^2t=k$ )
PR123 (0.2...1) xln with step 0.02 xln	0.1-0.2-0.4-0.8 s (@I>4xln with $t=k$ )
PR332 (0.2...1) xln with step 0.02xln	0.1...1s with step 0.05s (@I=4xln with $I^2t=k$ )
PR333 (0.2...1) xln with step 0.02xln	0.1...1s with step 0.05s (I>4xln with $t=k$ )
Here below the tolerances:	
$I4$	$t4$
PR222	± 15%
PR223	± 10%
PR212	± 20%
PR331	± 20%
PR121	
PR122	
PR123	± 15% ( $I^2t=k$ )
PR332	the better of the two data: ± 10% or 40ms (with $t=k$ )
PR333	

### 3 General characteristics

Trip curve  
electronic releases

**T2 160**  
**PR221DS**

L-I Functions

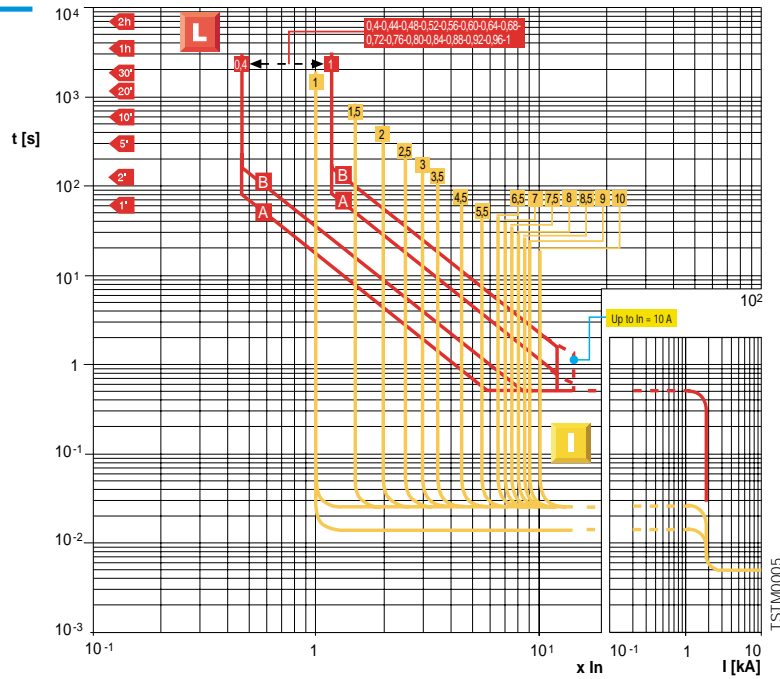

### 3 General characteristics

Trip curve  
electronic releases

**T2 160**  
**PR221DS**

L-S Functions

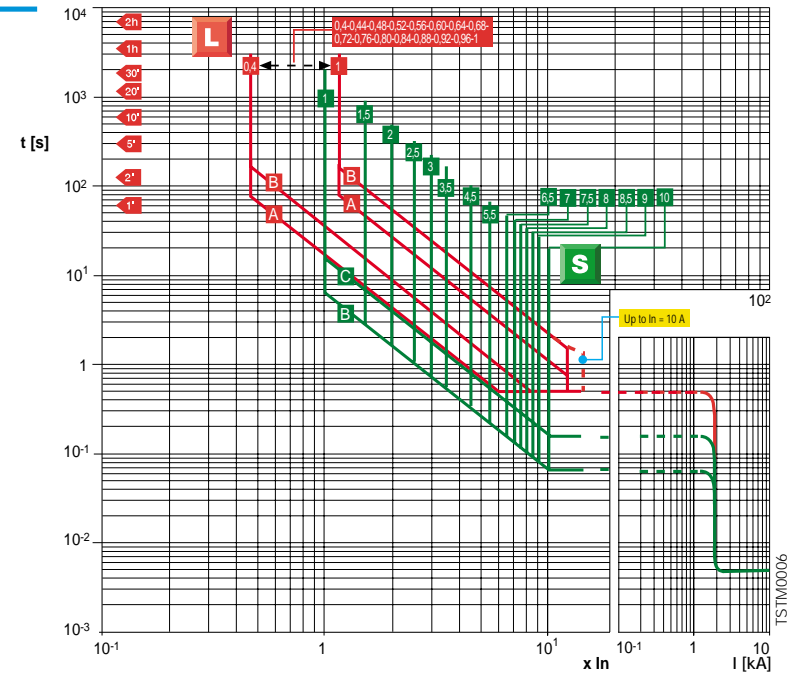

### 3 General characteristics

Trip curve  
electronic releases

T4 250/320  
T5 400/630  
T6 630/800/1000  
PR221DS

L-I Functions

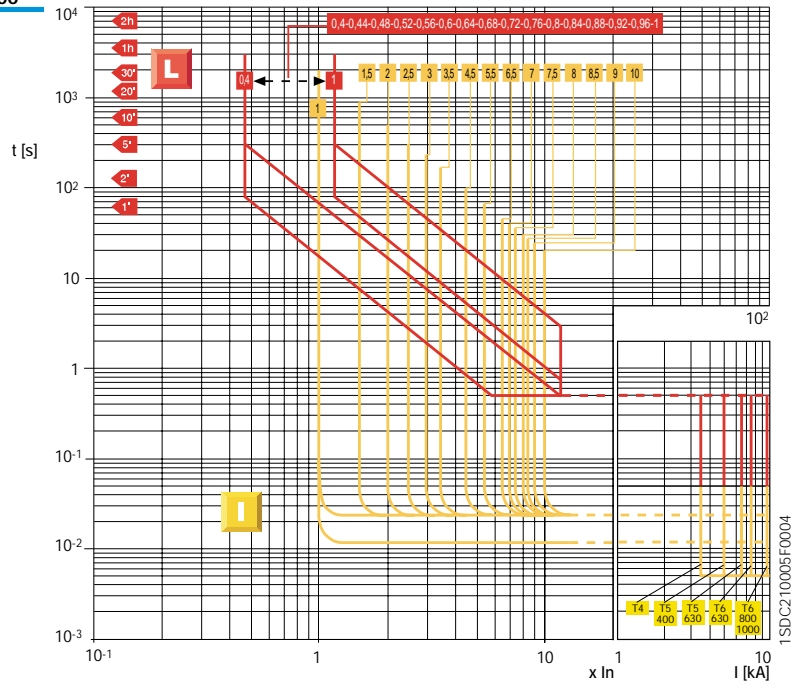

1SDC210005F0004

### 3 General characteristics

Trip curve  
electronic releases

T4 250/320  
T5 400/630  
T6 630/800/1000  
PR221DS

L-S Functions

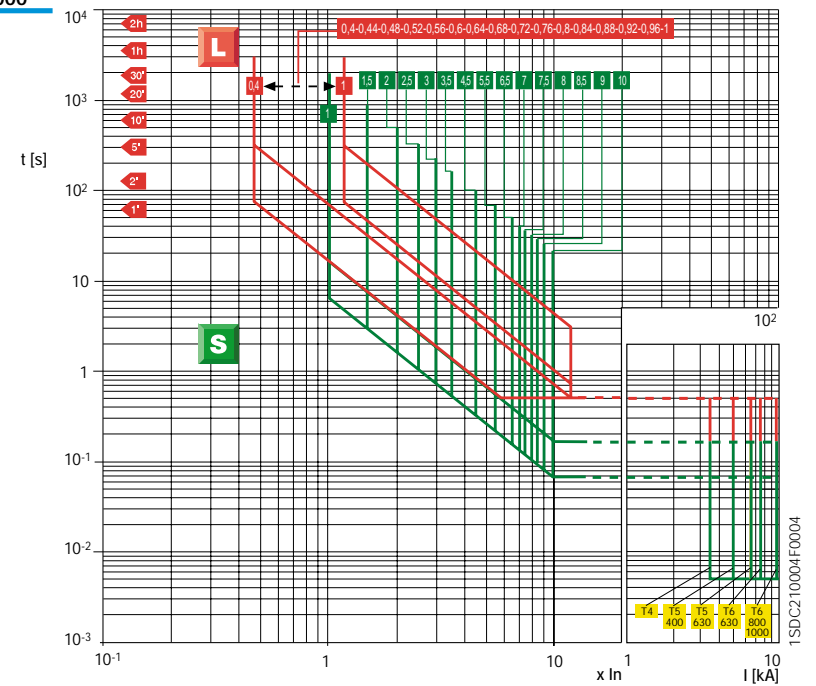

1SDC210004F0004

Note: for T4 In= 320A, T5 In=630A and T6 In=1000 ⇒ I<sub>2,max</sub> = 8,5 x In

### 3 General characteristics

Trip curve  
electronic releases

T4 250/320  
T5 400/630  
T6 630/800/1000

PR222DS/P  
PR222DS/PD  
PR223DS

L-S-I Functions  
(I<sup>2</sup>t const = ON) t [s]

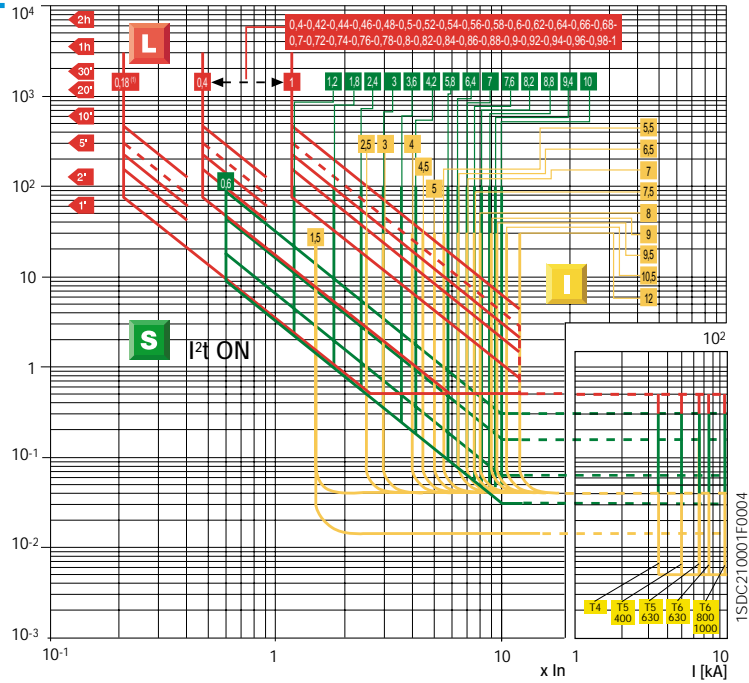

**Note:**

The dotted curve of function L corresponds to the maximum delay ( $t_1$ ) which can be set at  $6 \times I_{pr}$ , in the case where 320 A CTs are used for T4 and 630 A for T5. For all the CT sizes  $t_1 = 18$ s, except with 320 A CT (T4) and 630 A (T5) where  $t_1 = 12$ s. For T4  $I_n = 320$  A, T5  $I_n = 630$  A and T6  $I_n = 1000$  A  $\Rightarrow I_2 \text{ max} = 8.8 \times I_n$ ,  $I_3 \text{ max} = 9.5 \times I_n$

<sup>(1)</sup> For PR223DS the L protection function can be set to  $I_1 = 0,18 \dots 1 \times I_n$

### 3 General characteristics

Trip curve  
electronic releases

T4 250/320  
T5 400/630  
T6 630/800/1000

PR222DS/P  
PR222DS/PD  
PR223DS

L-S-I Functions  
(I<sup>2</sup>t const = OFF) t [s]

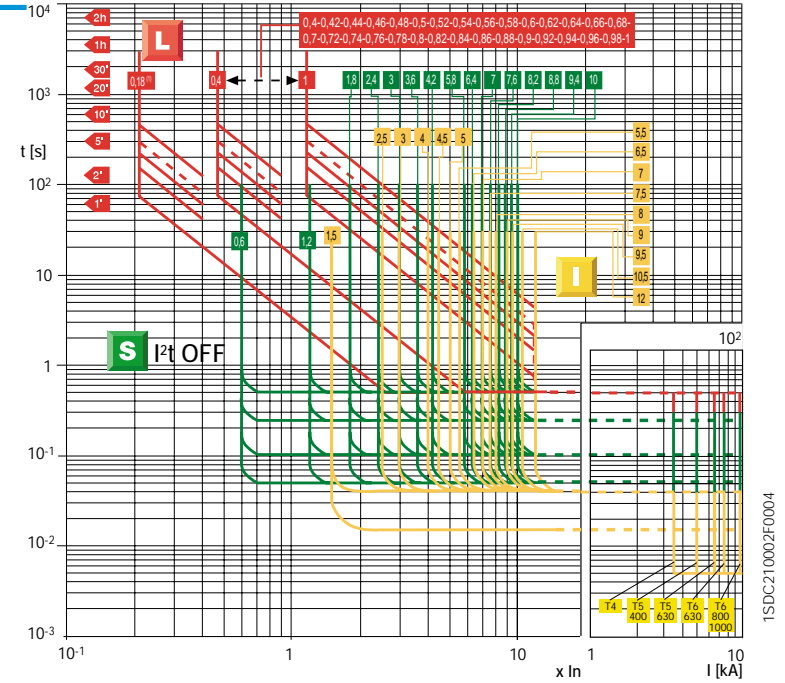

**Note:**

The dotted curve of function L corresponds to the maximum delay ( $t_1$ ) which can be set at  $6 \times I_{pr}$ , in the case where 320 A CTs are used for T4 and 630 A for T5. For all the CT sizes  $t_1 = 18$ s, except with 320 A CT (T4) and 630 A (T5) where  $t_1 = 12$ s. For T4  $I_n = 320$  A, T5  $I_n = 630$  A and T6  $I_n = 1000$  A  $\Rightarrow I_2 \text{ max} = 8.8 \times I_n$ ,  $I_3 \text{ max} = 9.5 \times I_n$

<sup>(1)</sup> For PR223DS the L protection function can be set to  $I_1 = 0,18 \dots 1 \times I_n$

### 3 General characteristics

Trip curve  
electronic releases

T4 250/320  
T5 400/630  
T6 630/800/1000

PR222DS  
PR222DS/PD  
PR223DS/EF

G Function

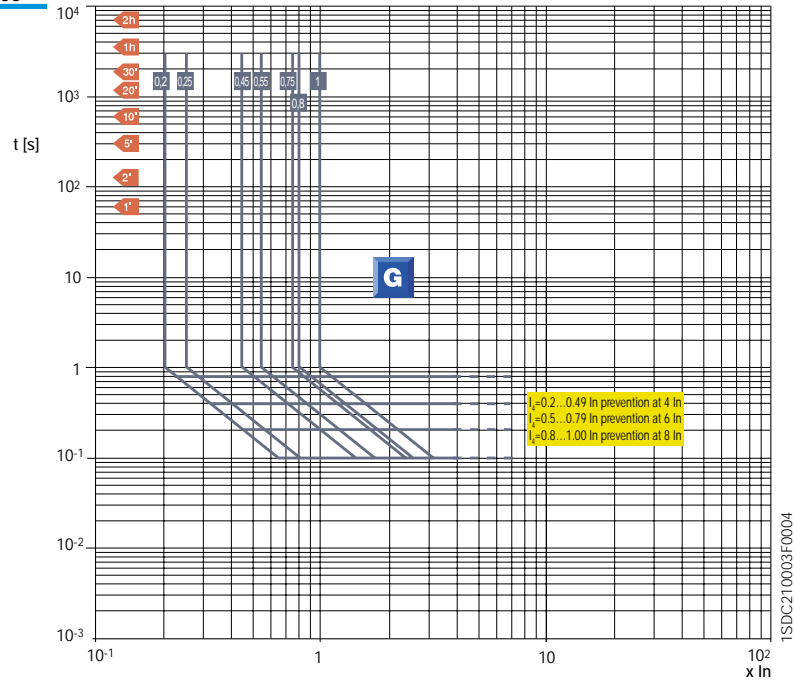

**Note:**  
For PR223DS and PR223EF the electronic settings only are available.

### 3 General characteristics

Trip curve  
electronic releases

T4L 250/320  
T5L 400/630  
T6L 630/800/1000

PR223EF  
Vaux ON  
L-S-EF Functions  
(I<sup>2</sup>t const = ON)  
(I<sup>2</sup>t const = OFF)

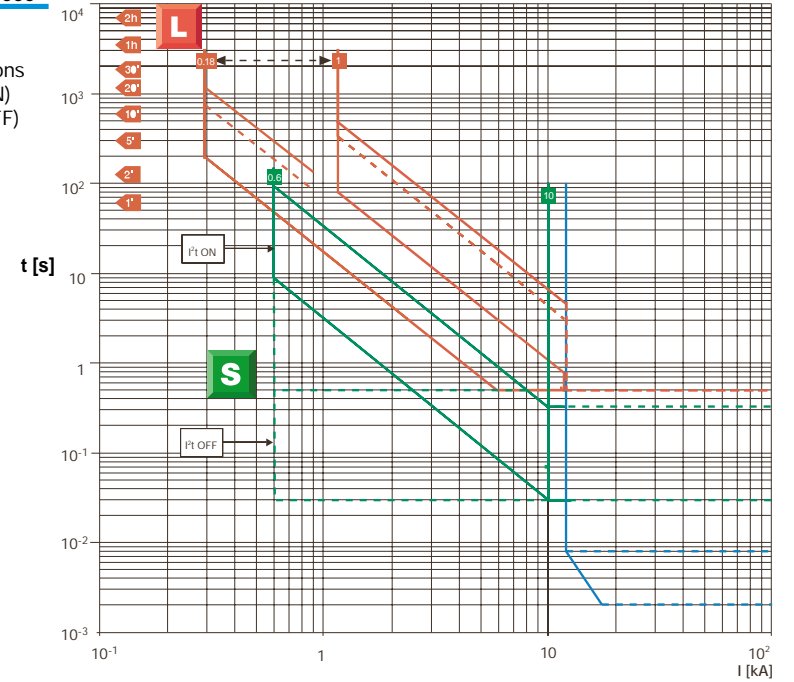

**Note:**  
The dotted curve for functional corresponds to the maximum delay ( $t_1$ ) which can be set at  $6 \times I_1$ , in the case where 320A CTS are used for T4 and 630A for T5. For all the CT sizes the maximum delay  $t_1$  is equal to 18s, except for 320 A CT (T4) and 630 A (T5) where  $t_1=12s$ . For T4  $I_n = 320$  A, T5  $I_n = 630$  A and T6  $I_n = 630$  A  $\Rightarrow I_2 \text{ max} = 8 \cdot 8 \times I_n$ ,  $I_2 \text{ max} = 9,5 \times I_n$ . Only the electronic settings are available.

### 3 General characteristics

Trip curve  
electronic releases

**T4L 250/320**  
**T5L 400/630**  
**T6L 630/800/1000**

**PR223EF**  
Vaux OFF  
L-S-EF Functions  
(I<sup>2</sup>t const = ON)  
(I<sup>2</sup>t const = OFF)

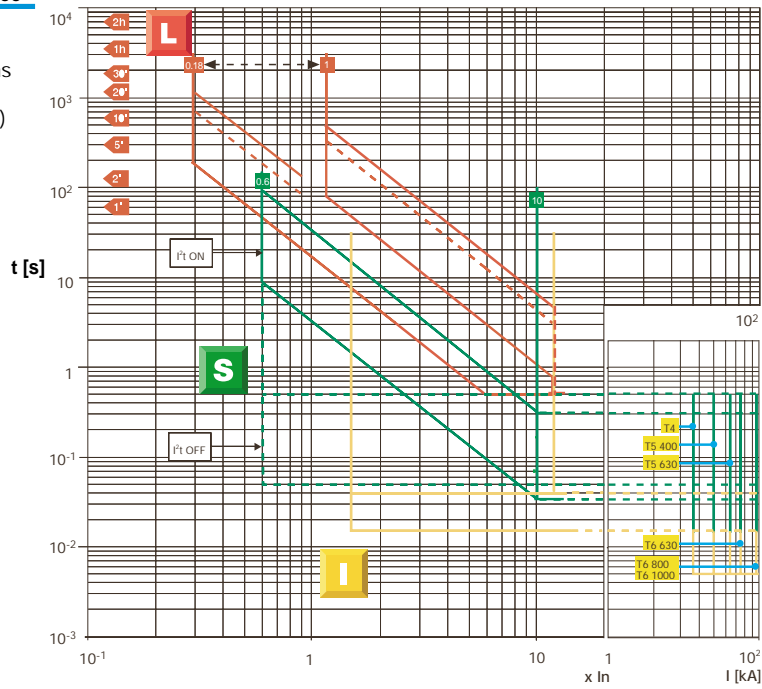

**Note:**

For all the CT sizes the maximum delay  $t_1$  is equal to 18s, except for 320 A CT (T4) and 630 A (T5) where  $t_1 = 12$ s.  
For T4 In = 320 A, T5 In = 630 A and T6 In = 630 A  $\Rightarrow I_3 \text{ max} = 10 \times I_n$ .  
Only the electronic settings are available.

### 3 General characteristics

Trip curve  
electronic releases

**T7**  
**800/1000/1250/1600**  
**PR231/P**  
L-I Functions

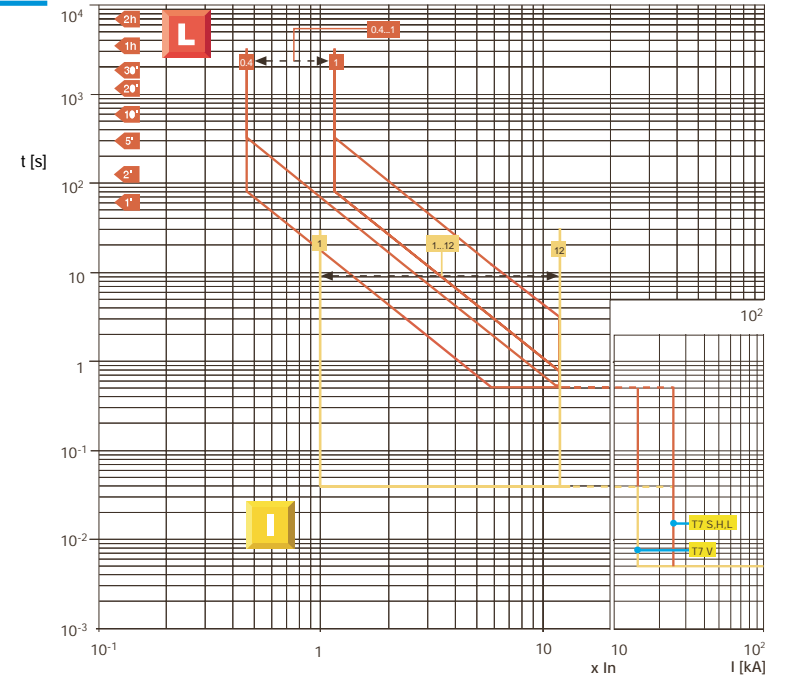

### 3 General characteristics

Trip curve  
electronic releases

**T7**  
**800/1000/1250/1600**  
**PR231/P**  
L-S Functions

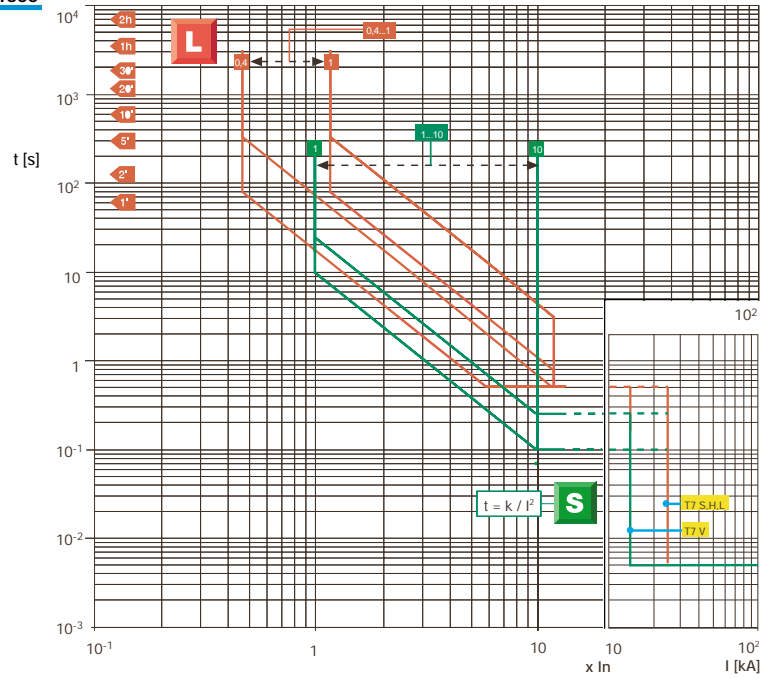

### 3 General characteristics

Trip curve  
electronic releases

**T7**  
**800/1000/1250/1600**  
**PR232/P**  
L-S-I Functions

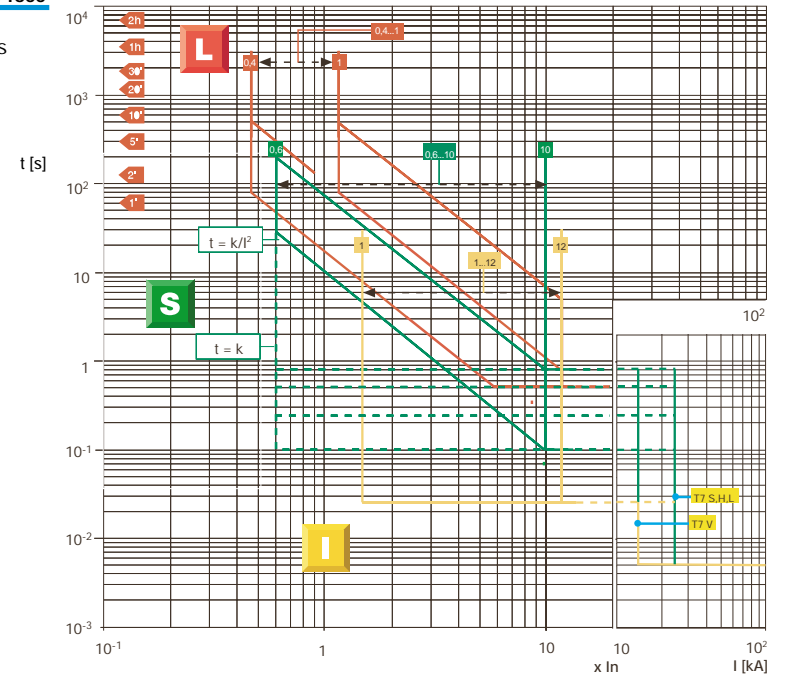

### 3 General characteristics

Trip curve  
electronic releases

**T7**  
**800/1000/1250/1600**  
**PR331/P**  
L-S-I Functions

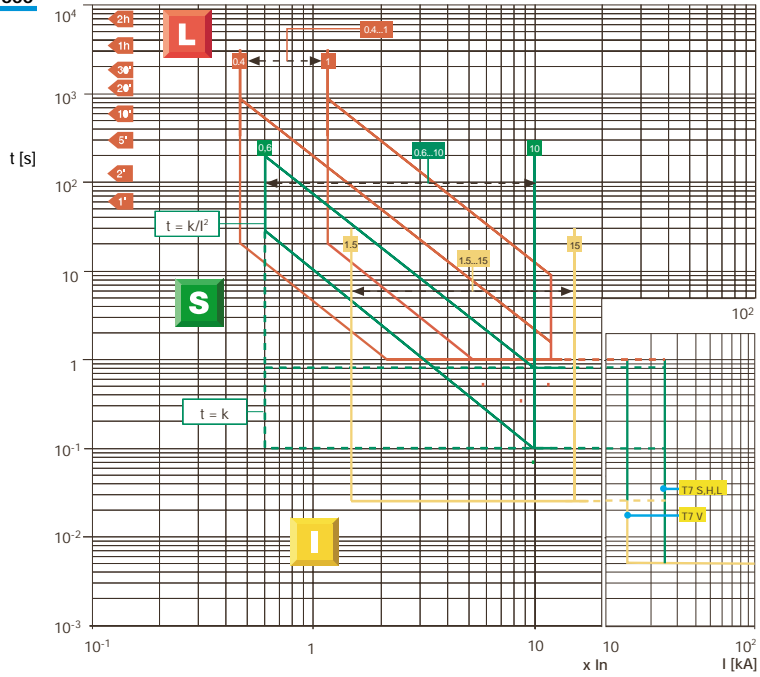

For T7  $I_n = 1250 \text{ A}, 1600 \text{ A} \Rightarrow I_s \text{ max} = 12 \times I_n$ .

### 3 General characteristics

Trip curve  
electronic releases

**T7**  
**800/1000/1250/1600**  
**PR331/P**  
G Functions

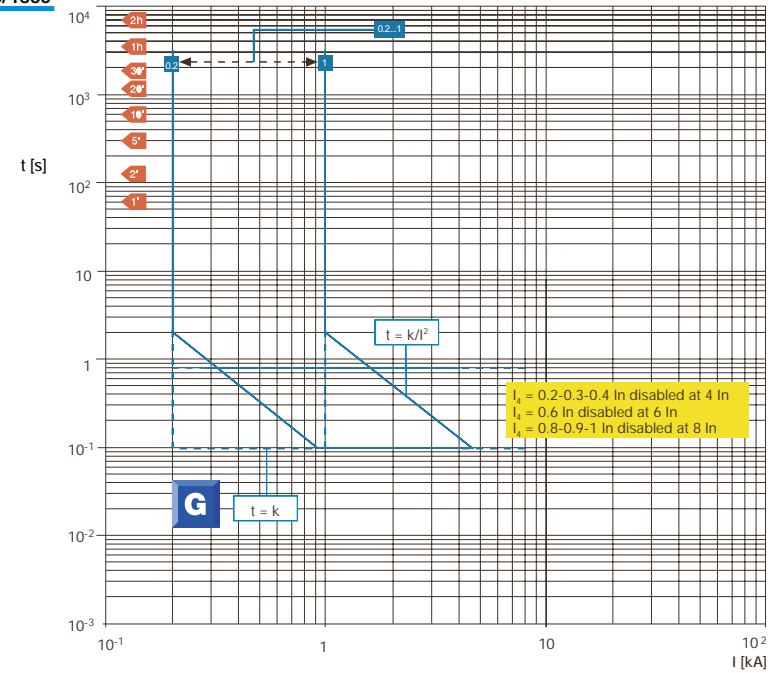





### 3 General characteristics

Trip curve  
electronic releases

**T7**  
**800/1000/1250/1600**  
**PR332/P**  
G Functions

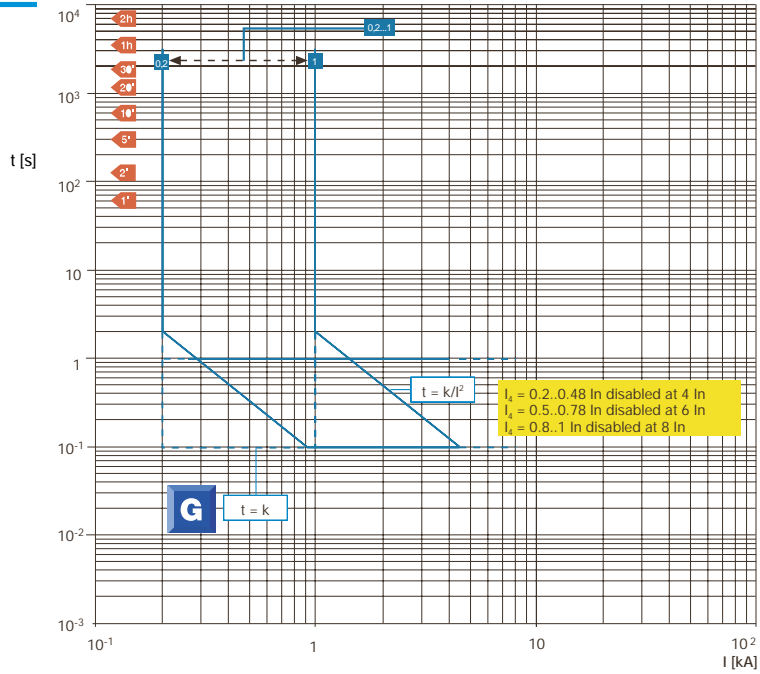

### 3 General characteristics

Trip curve  
electronic releases

**T7**  
**800/1000/1250/1600**  
**PR332/P**  
Rc Functions

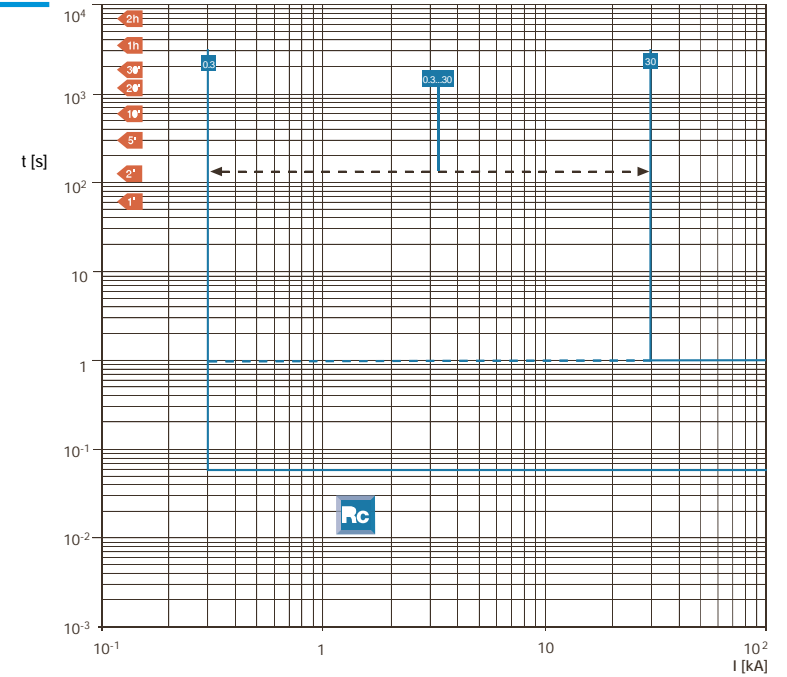

### 3 General characteristics

Trip curve  
electronic releases

**T2 160**  
**PR221DS-I**  
I Function

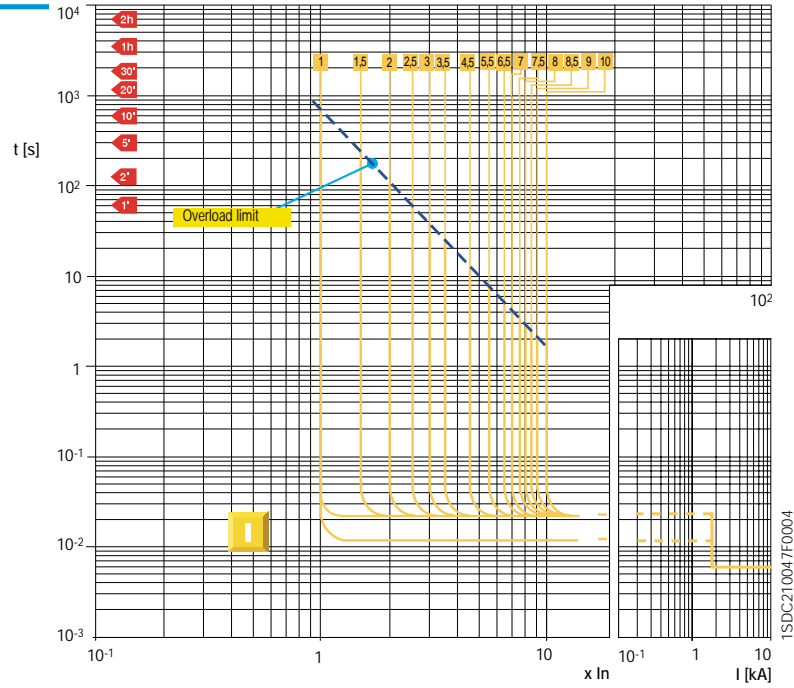

### 3 General characteristics

Trip curve  
electronic releases

**T4 250/320**  
**T5 400/630**  
**T6 630/800/1000**  
**PR221DS-I**  
I Function

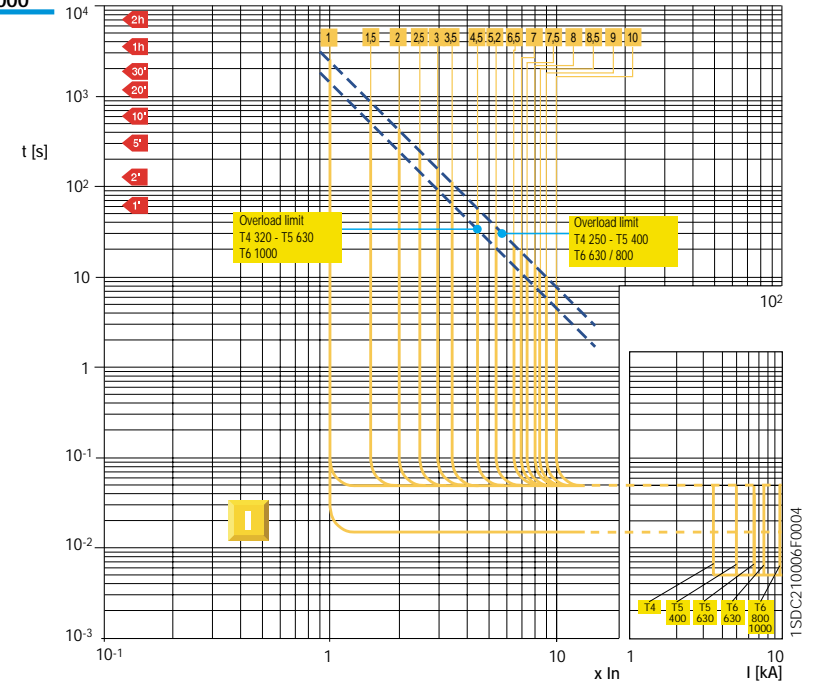

### 3 General characteristics

Trip curve  
electronic releases

**T7 800/1000/1250**

**PR231/P-I**

I Function

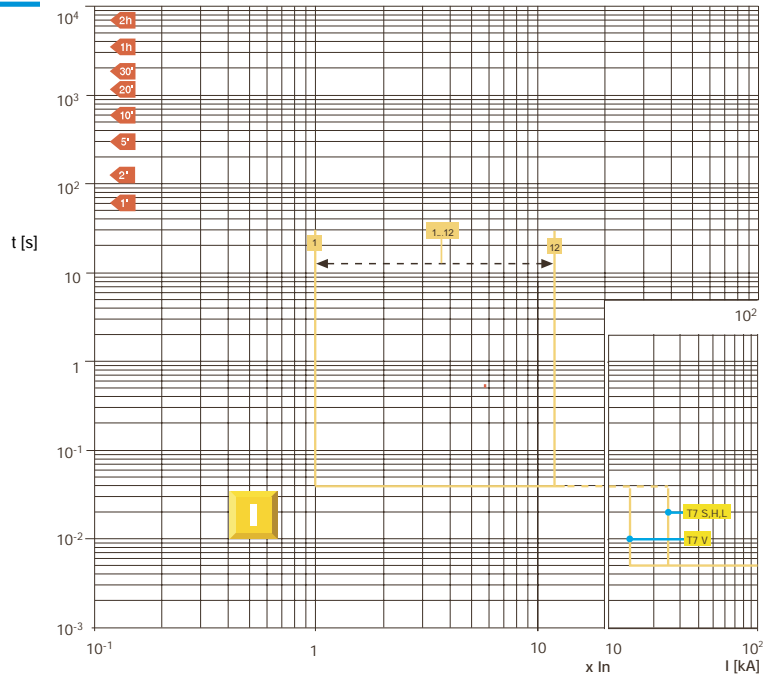

### 3 General characteristics

Trip curve  
electronic releases

**T4 250**

**T5 400**

**T6 800**

**PR222MP**

L Function  
(hot and cold trip)

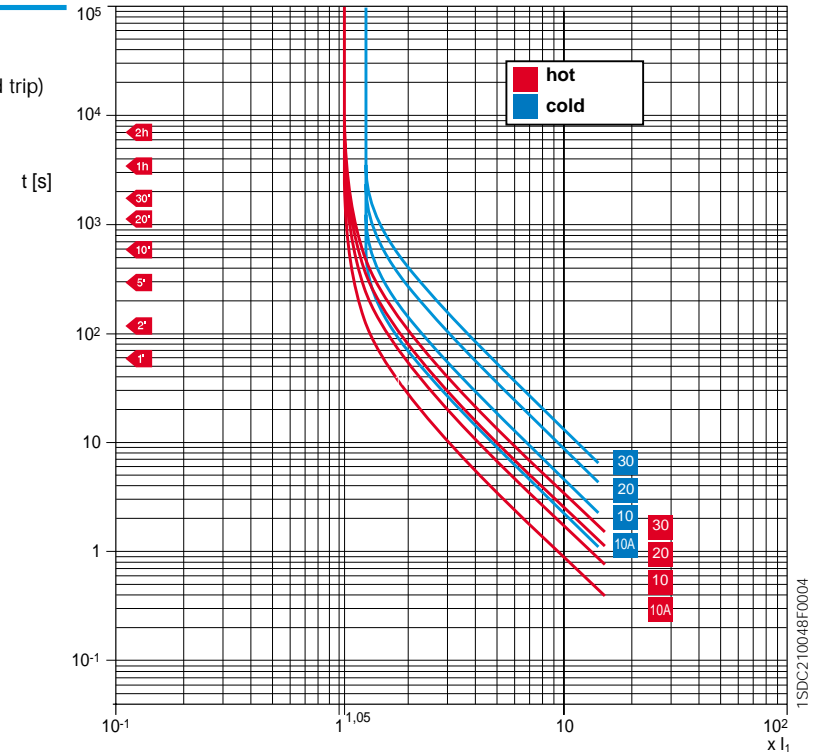

	$I_1$	$t_1$
PR222MP	$(0.4 \div 1) \times I_n$ with step $0.01 \times I_n$	4 – 8 – 16 – 24 s

Here the tolerances

	$I_1$	$t_1$
PR222MP	According to IEC 60947-4-1	According to IEC 60947-4-1

### 3 General characteristics

Trip curve  
electronic releases

T4 250  
T5 400  
T6 800  
**PR222MP**

L Function  
(hot trip with 1 or 2  
phases supplied)

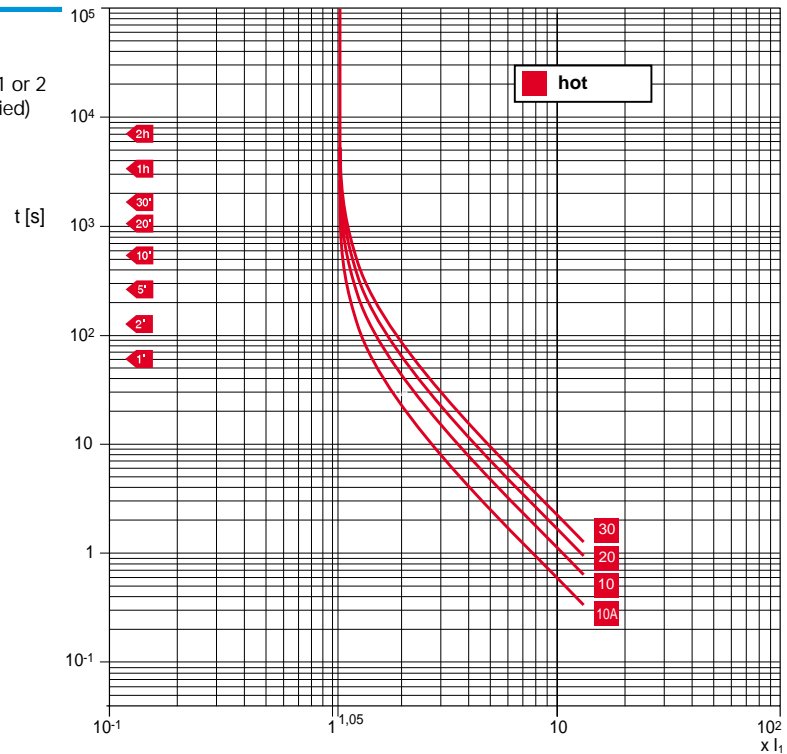

1SDC210049F0004

<b>I1</b>	<b>t1</b>
PR222MP	(0.4 ± 1) x In with step 0.01 x In
	4 - 8 - 16 - 24 s

Here the tolerances

<b>I1</b>	<b>t1</b>
PR222MP	±15%

### 3 General characteristics

Trip curve  
electronic releases

T4 250  
T5 400  
T6 800  
**PR222MP**

R-U Functions

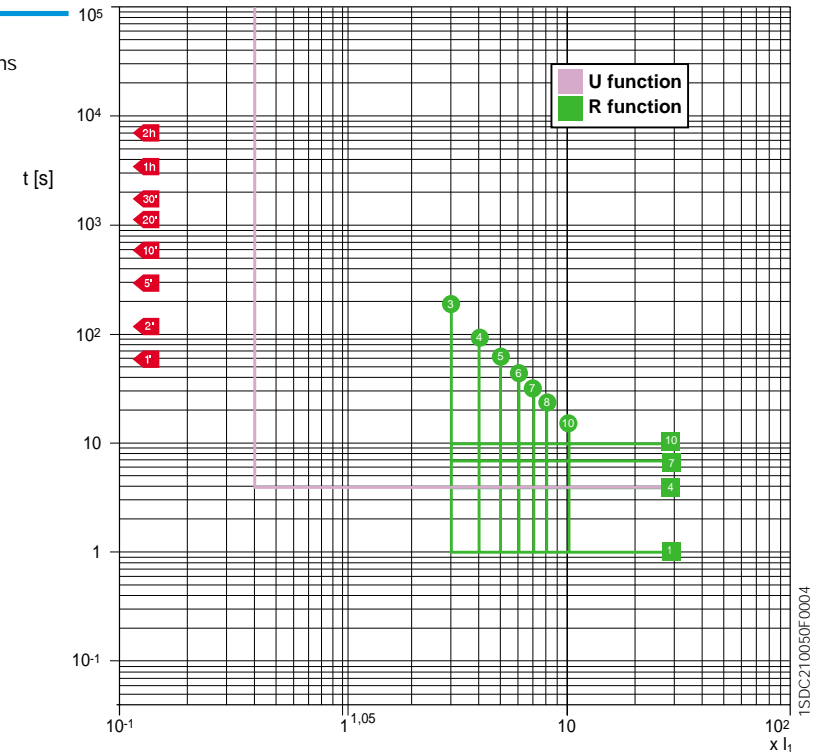

1SDC210050F0004

<b>R</b>	<b>I5</b>	<b>t5</b>
PR222MP	(3 - 4 - 5 - 6 - 7 - 8 - 10 - OFF) x I1	1 - 4 - 7 - 10 s

<b>U</b>	<b>I6</b>	<b>t6</b>
PR222MP	ON (0.4 x I1) - OFF	4 s

Here the tolerances

<b>R</b>	<b>I5</b>	<b>t5</b>
PR222MP	± 15 %	± 10 %

<b>U</b>	<b>I6</b>	<b>t6</b>
PR222MP	± 15 %	± 10 %

### 3 General characteristics

Trip curve  
electronic releases

T4 250  
T5 400  
T6 800  
**PR222MP**

I Functions

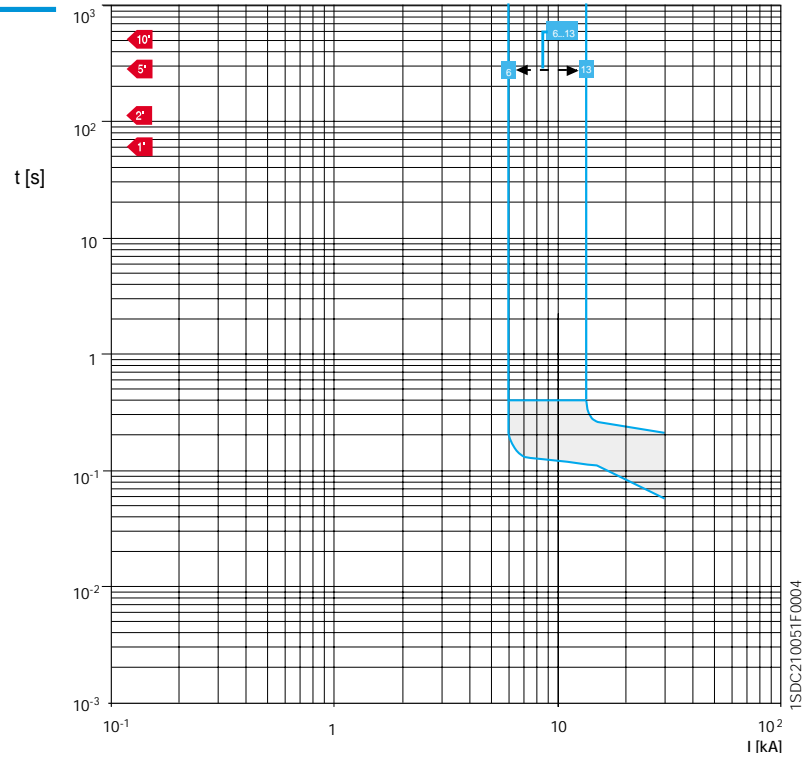

	<b>I3</b>
PR222MP	(6 - 7- 8 - 9 - 10 - 11 - 12 - 13) x I <sub>n</sub>

Here the tolerances

	<b>I3</b>
PR222MP	± 15 %

### 3 General characteristics

Trip curve  
electronic releases

**S7**  
**PR211/P**

L-I Functions

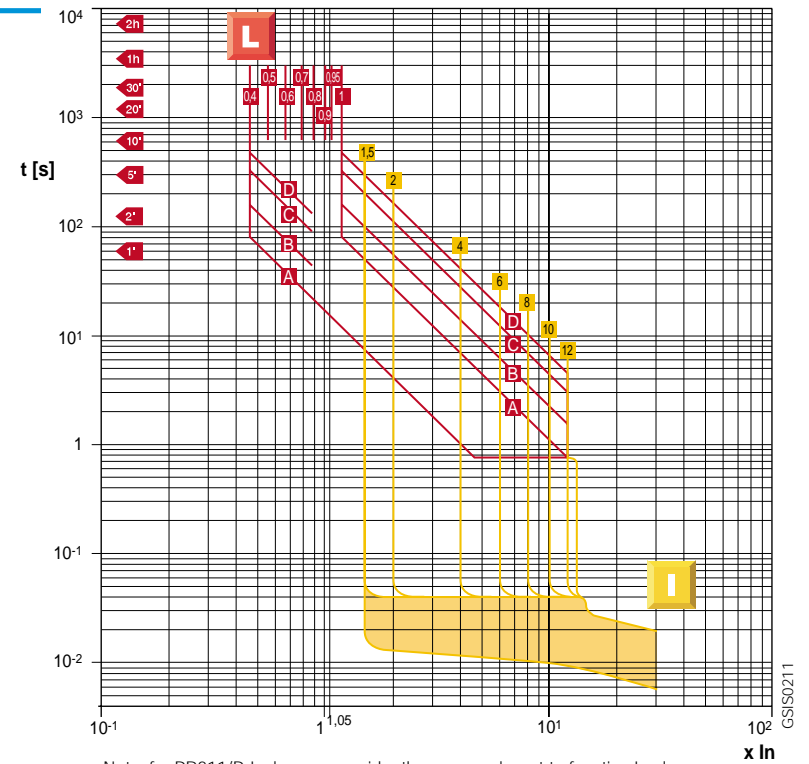

Note: for PR211/P-I releases, consider the curves relevant to function I only.

### 3 General characteristics

Trip curve  
electronic releases

**S7**

**PR212/P**

L-S-I Functions,  
S inverse short  
delay  
( $I^2t = \text{constant}$ )

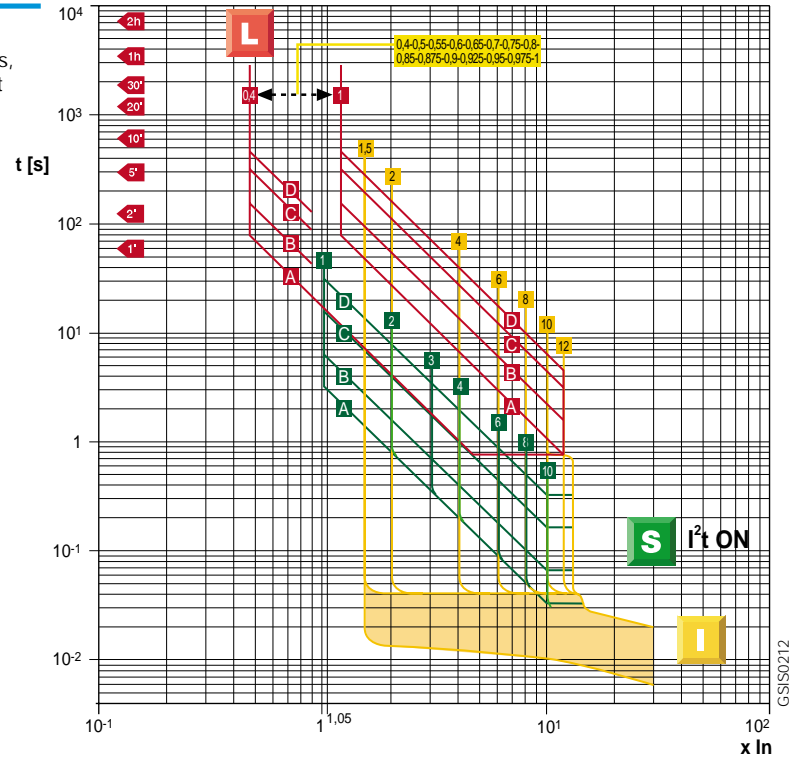

### 3 General characteristics

Trip curve  
electronic releases

**S7**

**PR212/P**

L-S-I Functions,  
S inverse short  
delay  
( $t = \text{constant}$ )

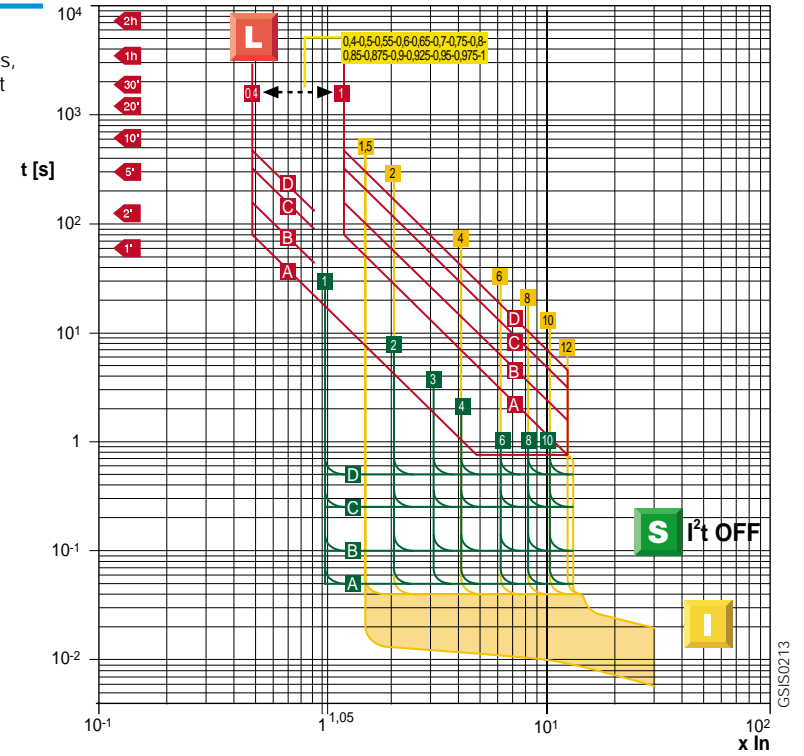

### 3 General characteristics

Trip curve  
electronic releases

**S7**

**PR212/P**

G Function

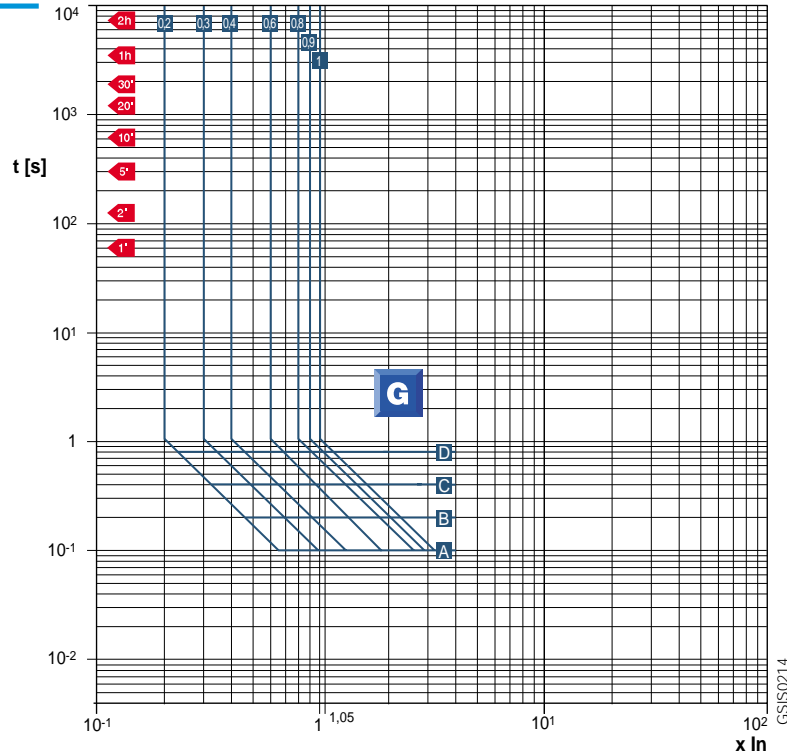

GSI0214

### 3 General characteristics

Trip curve  
electronic releases

**S7**

**PR212/MP**

L Function  
(hot and cold trip)

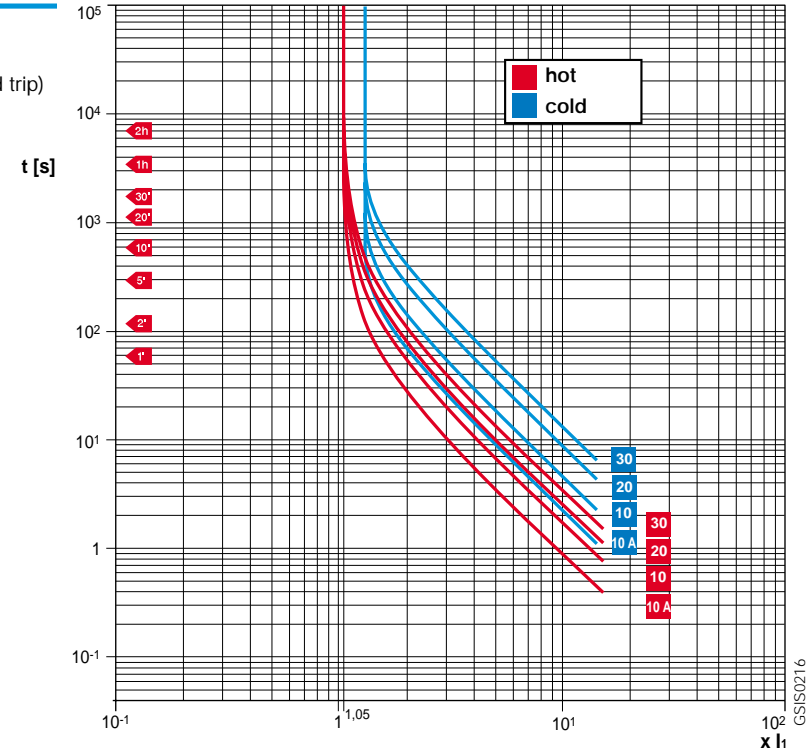

GSI0216

	<b>I<sub>1</sub></b>	<b>t<sub>1</sub></b>
PR212/MP	(0.4 ÷ 1) x I <sub>n</sub> with step 0.01 x I <sub>n</sub>	4 - 8 - 16 - 24 s

Here the tolerances

	<b>I<sub>1</sub></b>	<b>t<sub>1</sub></b>
PR212/MP	According to IEC 60947-4-1	According to IEC 60947-4-1



### 3 General characteristics

Trip curve  
electronic releases

**S7**

**PR212/MP**

L Function  
(hot trip with one  
or two phases  
supplied)

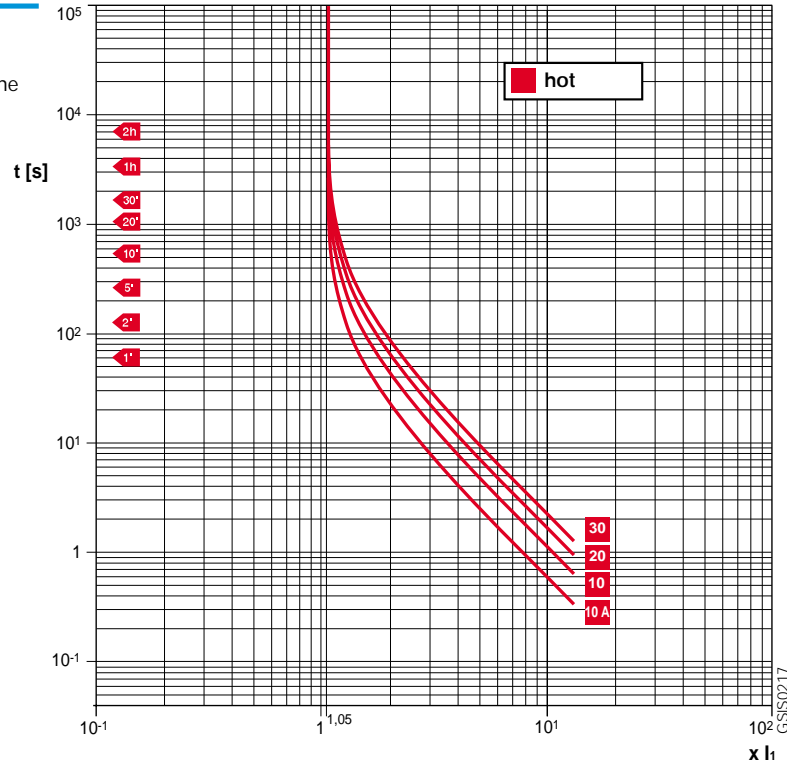

G5S0217

### 3 General characteristics

**S7**

**PR212/MP**

R-U Functions

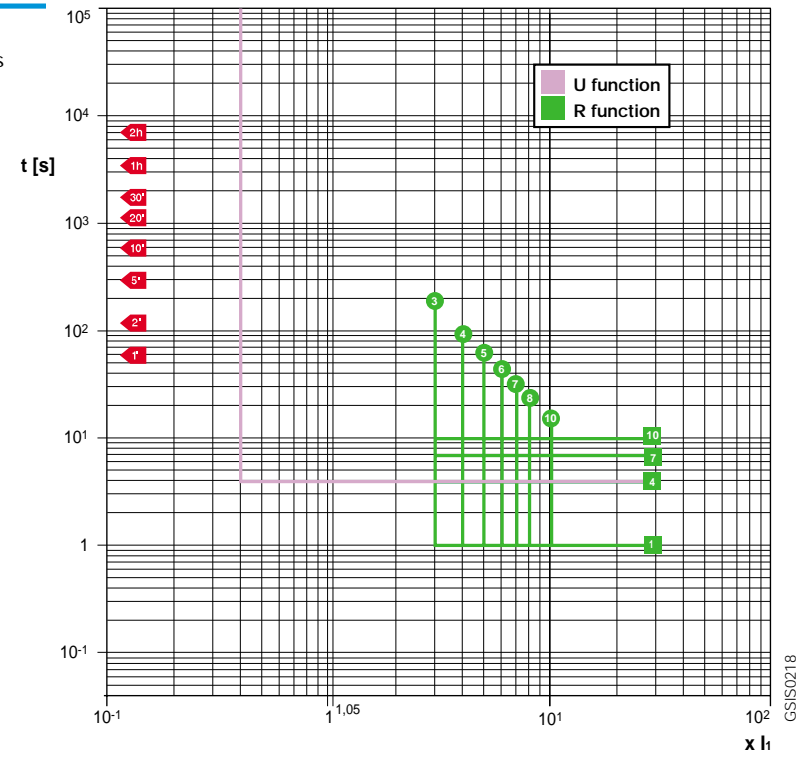

G5S0218

R	<b>I5</b>	<b>t5</b>
PR212/MP	(3 - 4 - 5 - 6 - 7 - 8 - 10 - OFF) x I1	1 - 4 - 7 - 10 s
U	<b>I6</b>	<b>t6</b>
PR212/MP	0.4 x I1	4 s

Here the tolerances

R	<b>I5</b>	<b>t5</b>
PR212/MP	± 10 %	± 20 %
U	<b>I6</b>	<b>t6</b>
PR212/MP	± 20 %	± 20 %

### 3 General characteristics

Trip curve  
electronic releases

**S7**

**PR212/MP**

I Function

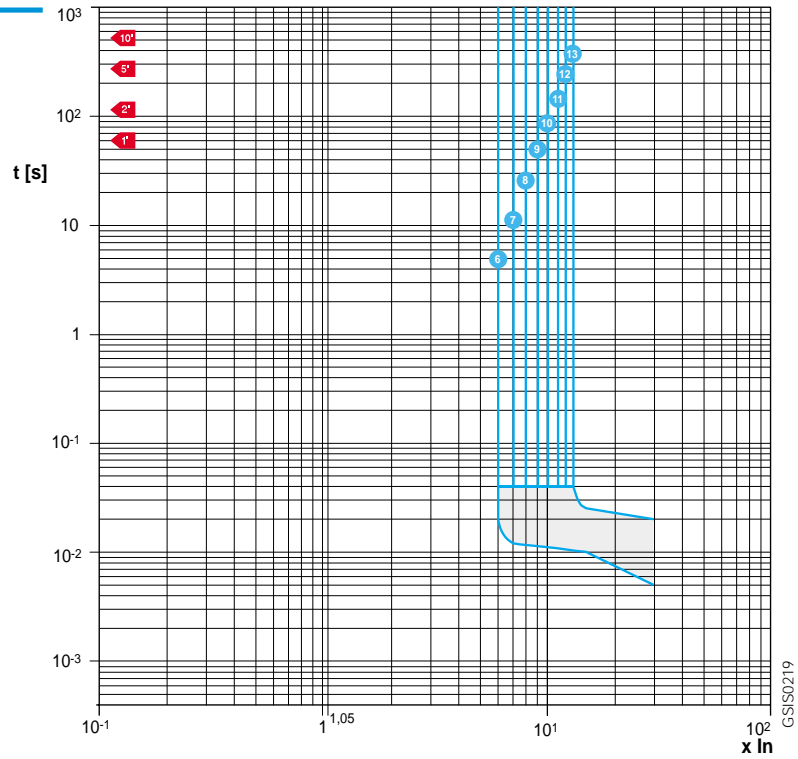

G3/S0219

**13**

PR212/MP (6 - 7 - 8 - 9 - 10 - 11 - 12 - 13 - OFF) x In

The tolerances are according to IEC 60947-4-1.

### 3 General characteristics

Trip curve  
electronic releases

**Emax**

**PR121/P**

**PR331/P**

L- I Functions

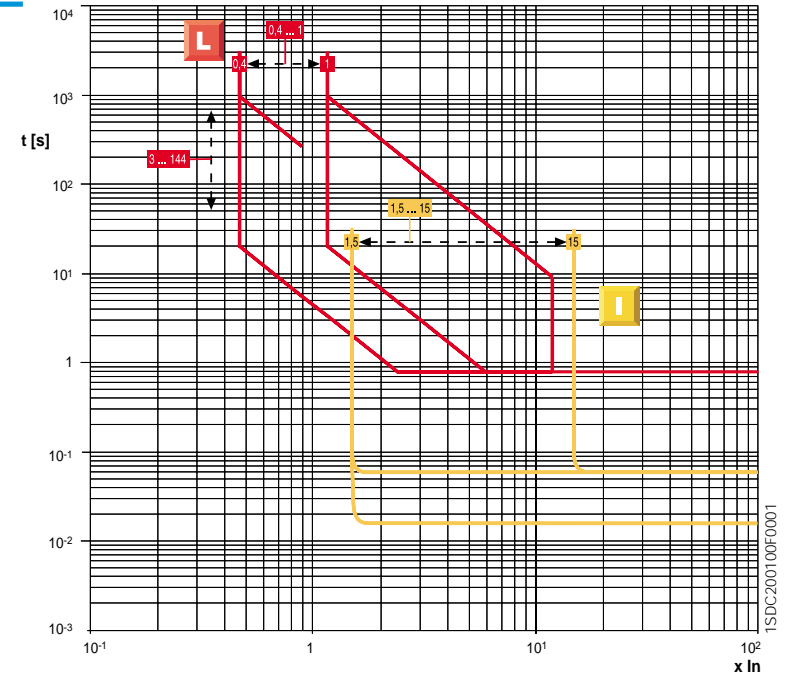

TSDC200100F0001

### 3 General characteristics

Trip curve  
electronic releases

**Emax**

PR121/P  
PR331/P

L-S-I Functions,  
S inverse short  
time delay  
( $I^2t = \text{const.}$ )

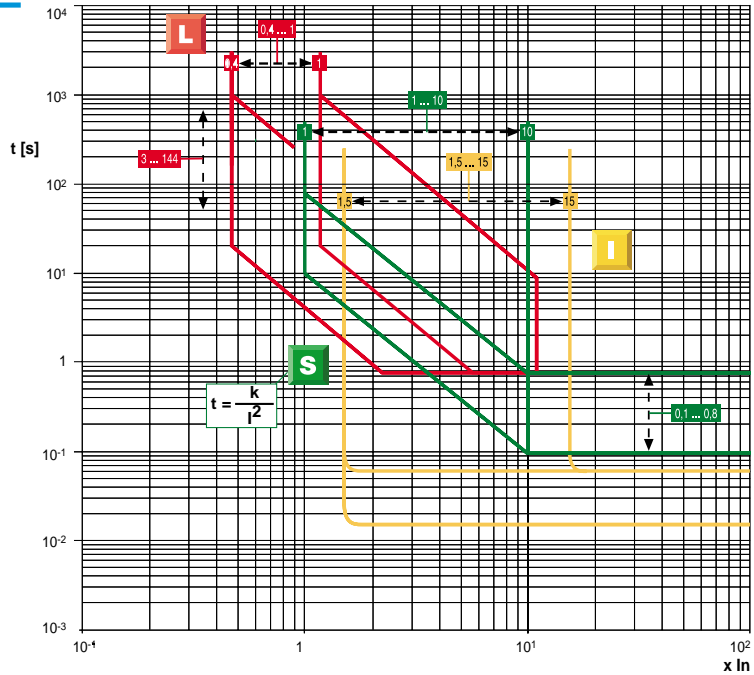

15DC200101F0001

### 3 General characteristics

Trip curve  
electronic releases

**Emax**

PR121/P  
PR331/P

L-S-I Functions,  
S independent  
time delay  
( $t = \text{constant}$ )

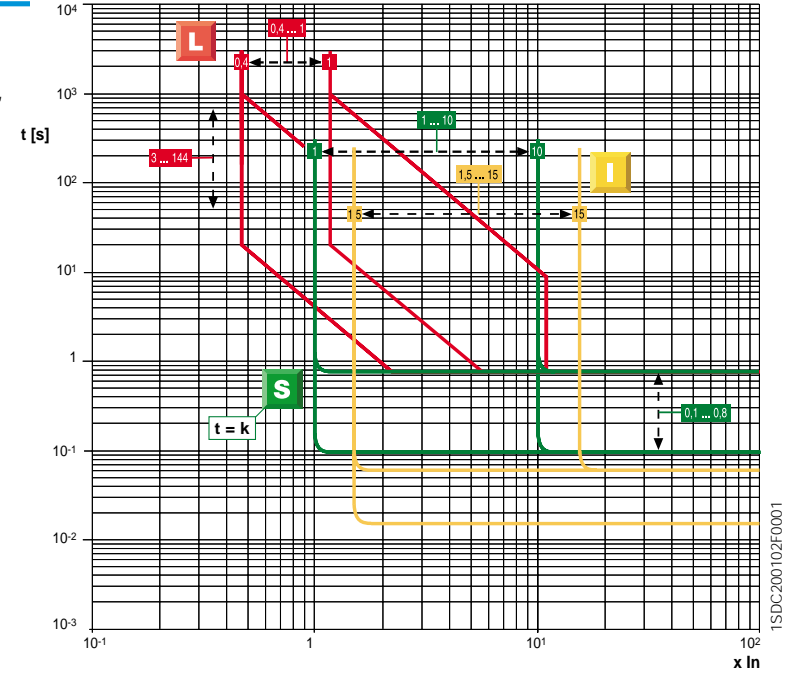

15DC200102F0001

### 3 General characteristics

Trip curve  
electronic releases

**Emax**  
PR121/P  
PR331/P

G Function

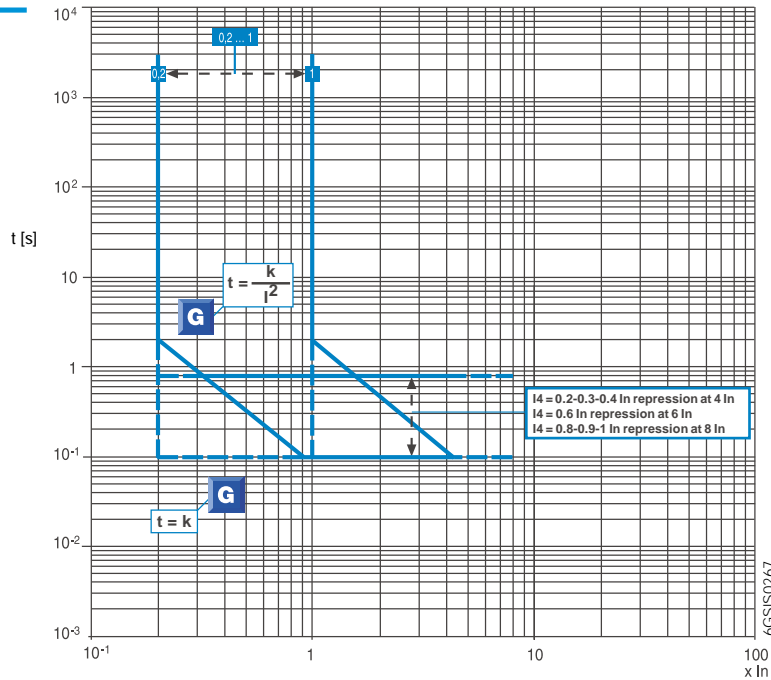

### 3 General characteristics

Trip curve  
electronic releases

**Emax**  
PR122/P  
PR332/P  
L-I Functions

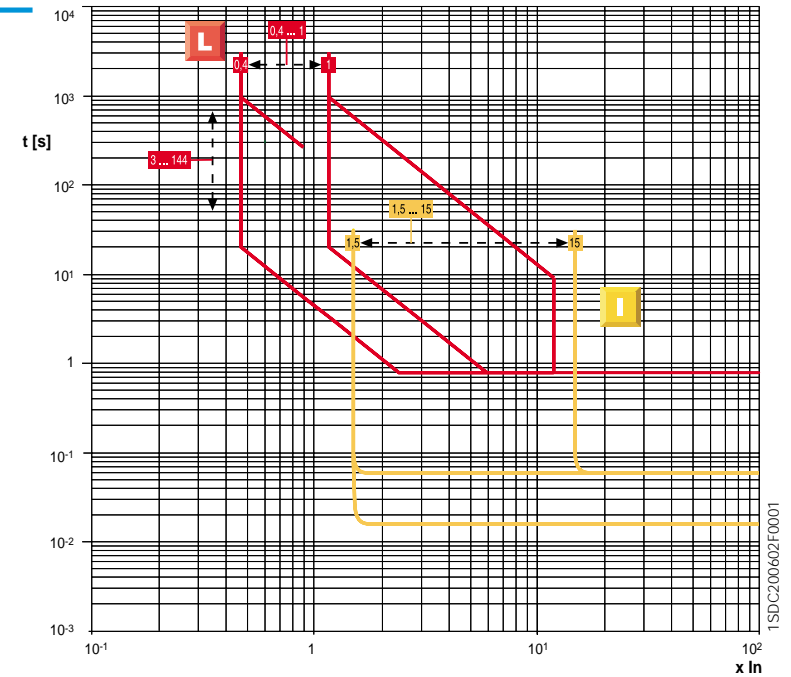

### 3 General characteristics

Trip curve  
electronic releases

**Emax**  
PR122/P-PR123/P  
PR332/P- PR333/P

L-S-I Functions  
S inverse short  
time delay  
( $I^2t = \text{const.}$ )

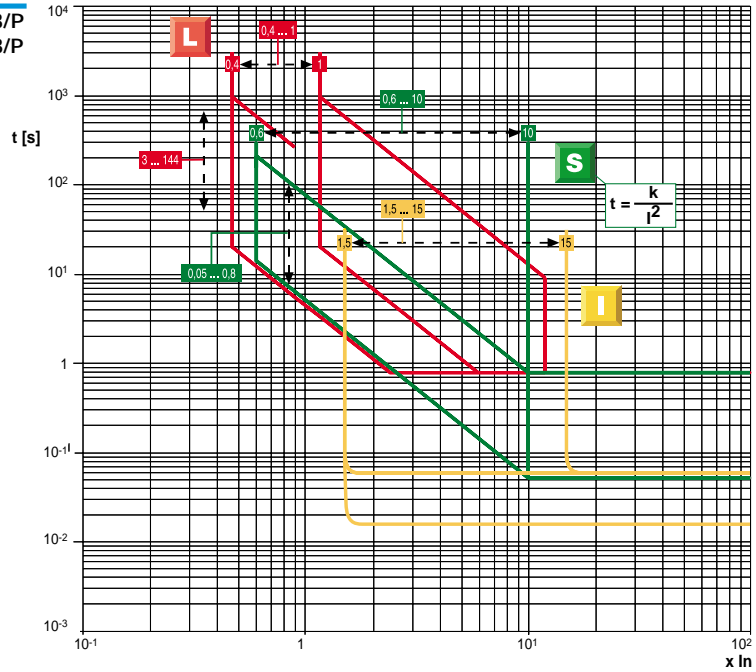

### 3 General characteristics

Trip curve  
electronic releases

**Emax**  
PR122/P-PR123/P  
PR332/P- PR333/P

L-S-I Functions  
S independent  
time delay  
( $t = \text{constant}$ )

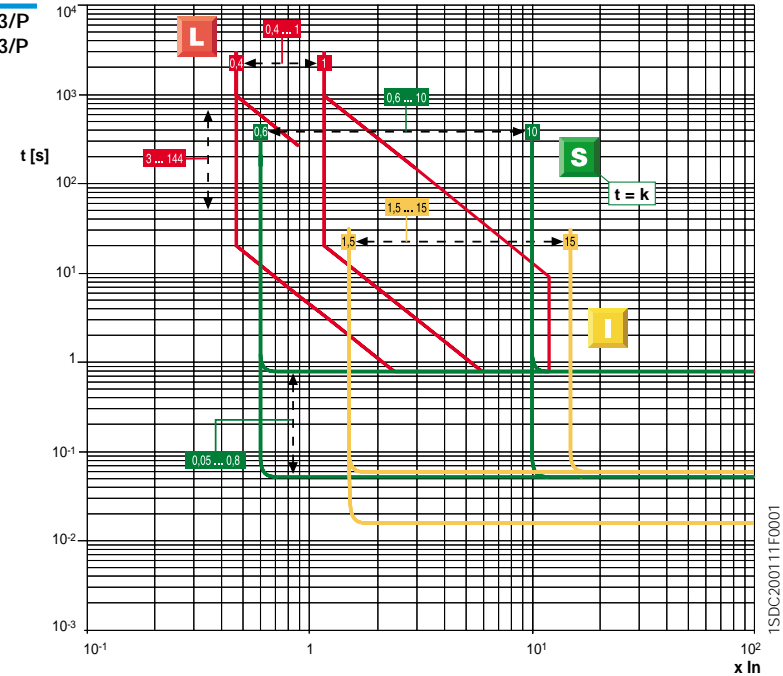

### 3 General characteristics

Trip curve  
electronic releases

**E<sub>max</sub>**  
PR122/P-PR123/P  
PR332/P- PR333/P

G Function

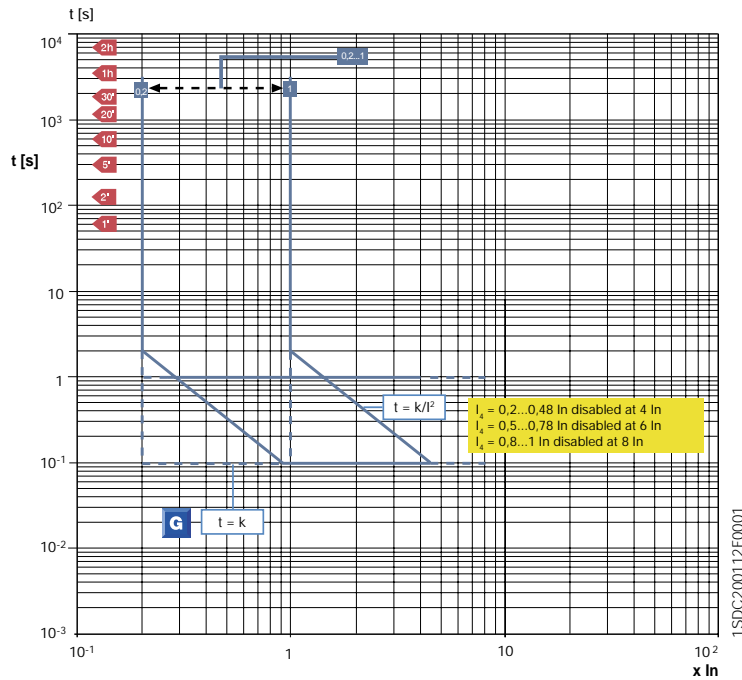

1SDC200112F0001

### 3 General characteristics

#### PR123/P release – Function L in compliance with Std. IEC 60255-3

The following three curves refer to the protection function L complying with Std. IEC 60255-3 and integrate the standard one; they are applicable in coordination with fuses and MV circuit-breakers.

Trip curve  
electronic releases

**E<sub>max</sub>**  
PR123/P  
PR332/P- PR333/P

**T<sub>max</sub>**  
PR332/P

L Function  
(IEC 60255-3)

**k=0.14 alfa=0.02**

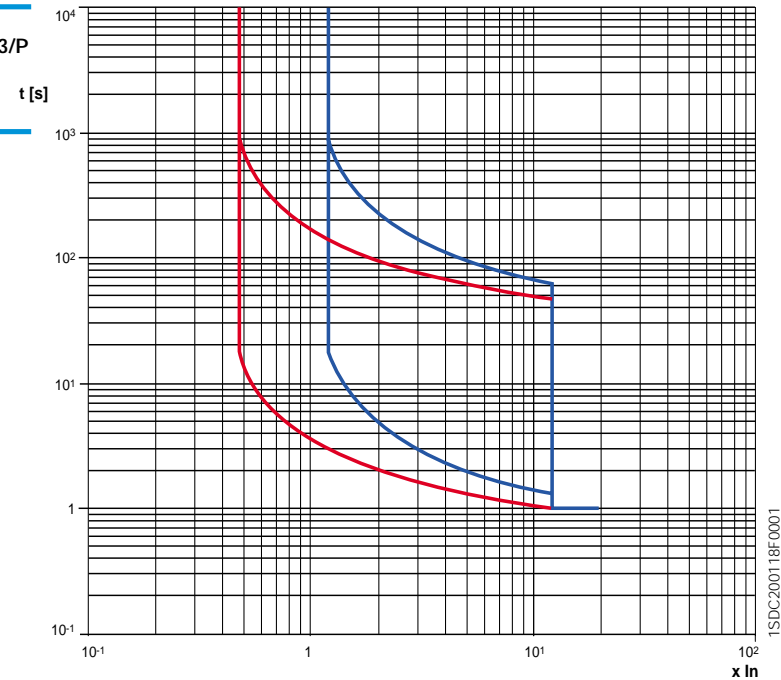

1SDC200118F0001

	<b>I<sub>1</sub></b>	<b>t<sub>1</sub></b>
PR123/P PR332/P-PR333/P	(0.4...1) x I <sub>n</sub> with step 0.01 x I <sub>n</sub>	t <sub>1</sub> =3s...144s with step 3s (1) (@ I=3 x I <sub>n</sub> )
Here below the tolerances:		
	<b>I<sub>1</sub></b>	
PR123/P PR332/P-PR333/P	1.05...1.2 x I <sub>n</sub>	± 20 % I <sub>g</sub> > 5 x I <sub>1</sub> ± 30 % 2 x I <sub>1</sub> ≤ I <sub>g</sub> ≤ 5 x I <sub>1</sub> I <sub>n</sub>

<sup>(1)</sup>The minimum trip values is 1 s, regardless of the type of curve set (self protection)

### 3 General characteristics

Trip curve  
electronic releases

**k=13.5 alfa=1**

**Emax**  
PR123/P  
PR332/P- PR333/P

**Tmax**  
PR332/P

L Function  
(IEC 60255-3)

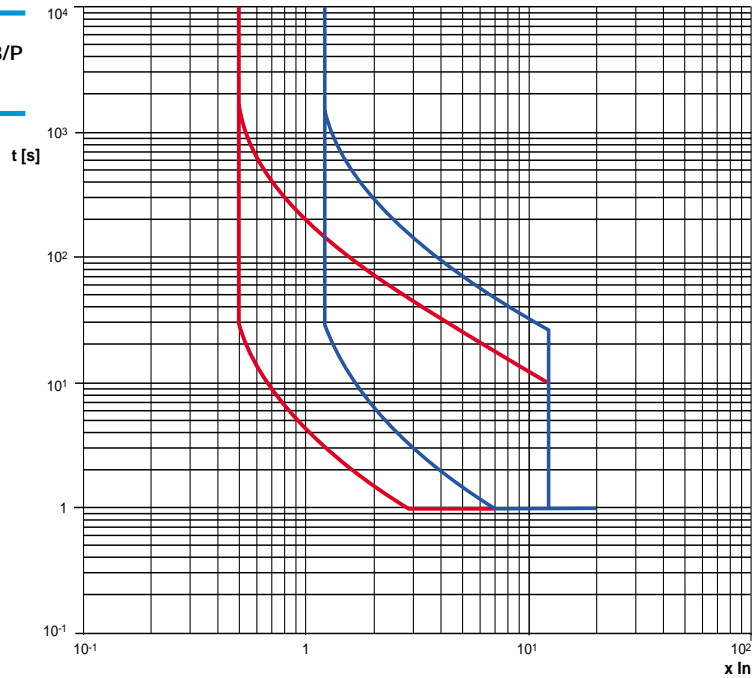

1SDC200119F0001

	<b>I1</b>	<b>t1</b>
PR123/P PR332/P-PR333/P	(0.4...1) x In with step 0.01 x In	t1=3s...144s with step 3s (1) (@ I=3 x Un)

Here below the tolerances:

	<b>I1</b>	
PR123/P PR332/P-PR333/P	1.05...1.2 x In	± 20 % I <sub>g</sub> > 5 x I <sub>1</sub> ± 30 % 2 x I <sub>1</sub> ≤ I <sub>g</sub> ≤ 5 x I <sub>1</sub> In

<sup>(1)</sup>The minimum trip values is 1 s, regardless of the type of curve set (self protection)

### 3 General characteristics

Trip curve  
electronic releases

**k=80 alfa=2**

**Emax**  
PR123/P  
PR332/P- PR333/P

**Tmax**  
PR332/P

L Function  
(IEC 60255-3)

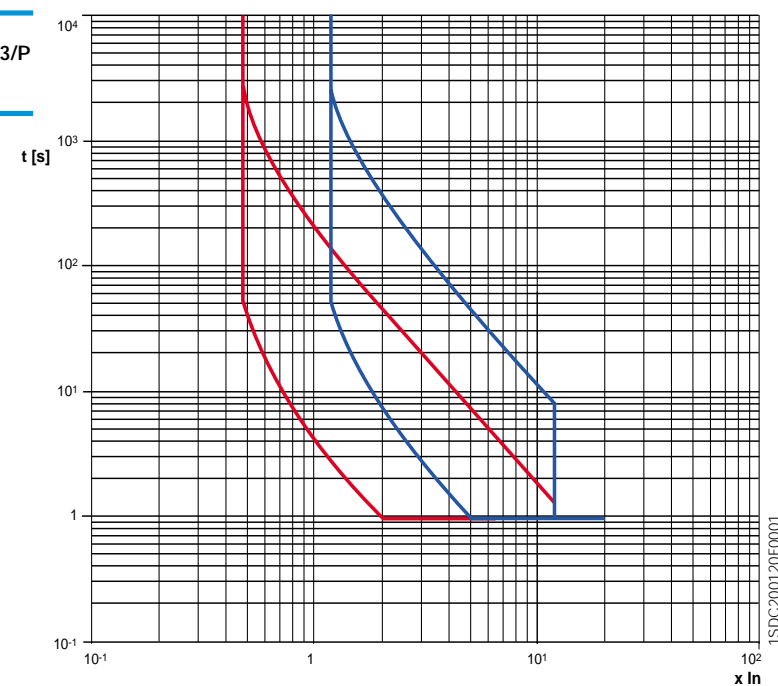

1SDC200120F0001

	<b>I1</b>	<b>t1</b>
PR123/P PR332/P-PR333/P	(0.4...1) x In with step 0.01 x In	t1=3s...144s with step 3s (1) (@ I=3 x Un)

Here below the tolerances:

	<b>I1</b>	
PR123/P PR332/P-PR333/P	1.05...1.2 x In	± 20 % I <sub>g</sub> > 5 x I <sub>1</sub> ± 30 % 2 x I <sub>1</sub> ≤ I <sub>g</sub> ≤ 5 x I <sub>1</sub> In

<sup>(1)</sup>The minimum trip values is 1 s, regardless of the type of curve set (self protection)

### 3 General characteristics

Trip curve  
electronic releases

**E<sub>max</sub>**  
PR123/P  
PR333/P

Function D

#### PR 122/PR123 release – Other protection functions

The following curves refer to the particular protection functions provided for PR122/PR123/PR332/PR333.

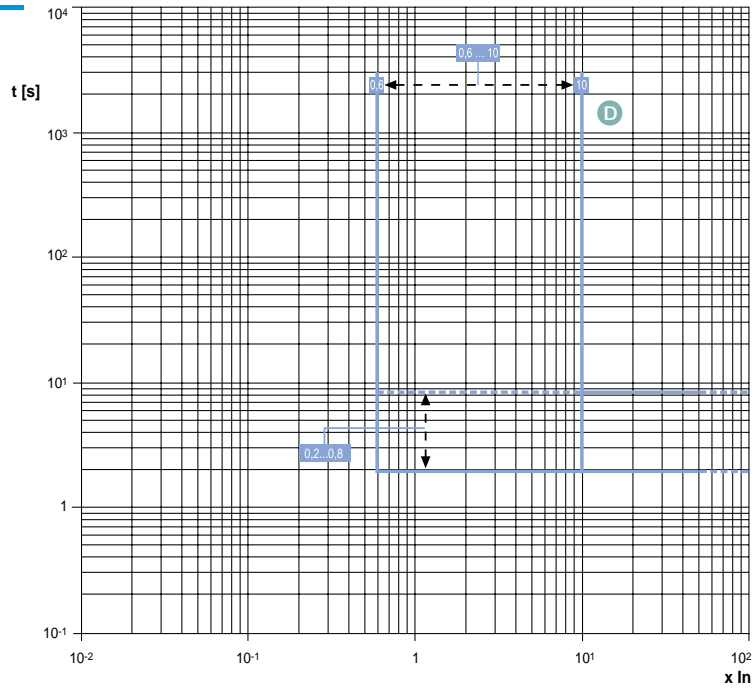

1SDC200121F0001

	<b>I<sub>7</sub></b>	<b>t<sub>7</sub></b>
PR123/P PR333/P	(0.6 ... 10 – OFF) x I <sub>n</sub> with step 0.1 x I <sub>n</sub>	0.2s ... 0.8s with step 0.01s (@ I > I <sub>7</sub> )
	Here below the tolerances:	
PR123/P PR333/P	± 10 %	the better of the two figures: ± 10 % or ± 40 ms

### 3 General characteristics

Trip curve  
electronic releases

**E<sub>max</sub>**  
PR332/P-PR333/P  
PR122/P-PR123/P

**T<sub>max</sub>**  
PR332/P  
Function U

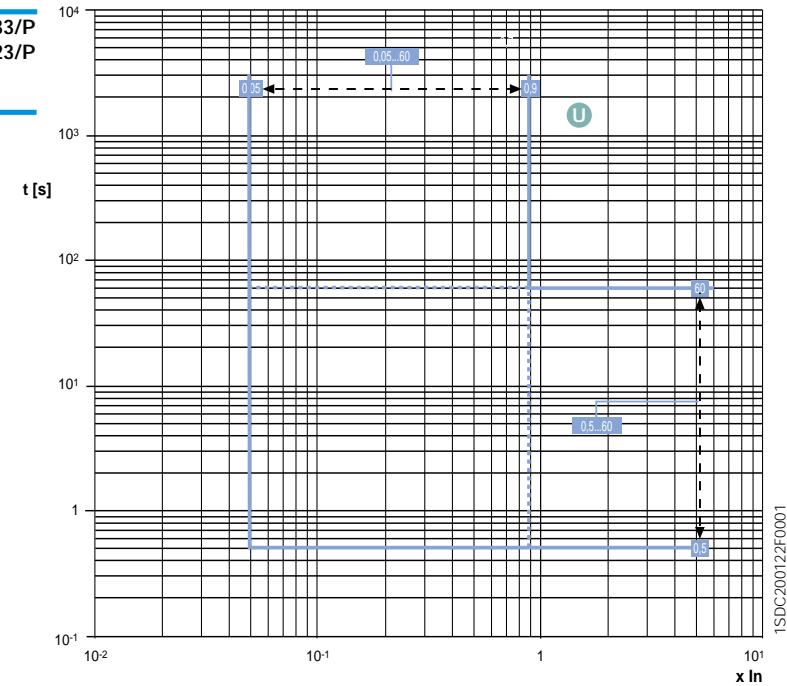

1SDC200121F0001

	<b>I<sub>6</sub></b>	<b>t<sub>6</sub></b>
PR122/P-PR123/P PR332/P-PR333/P	(5%...90% – OFF) with step 5%	0.5 ... 60s with step 0.5s
	Here below the tolerances:	
PR122/P-PR123/P PR332/P-PR333/P	± 10 %	The better of the two figures: ± 20 % or ± 100 ms



### 3 General characteristics

Trip curve  
electronic releases

**Emax**  
PR332/P\*-PR333/P  
PR122/P\*\*-PR123/P

**Tmax**  
PR332/P\*

Function UV  
\*with PR330/V  
\*\*with PR120/V

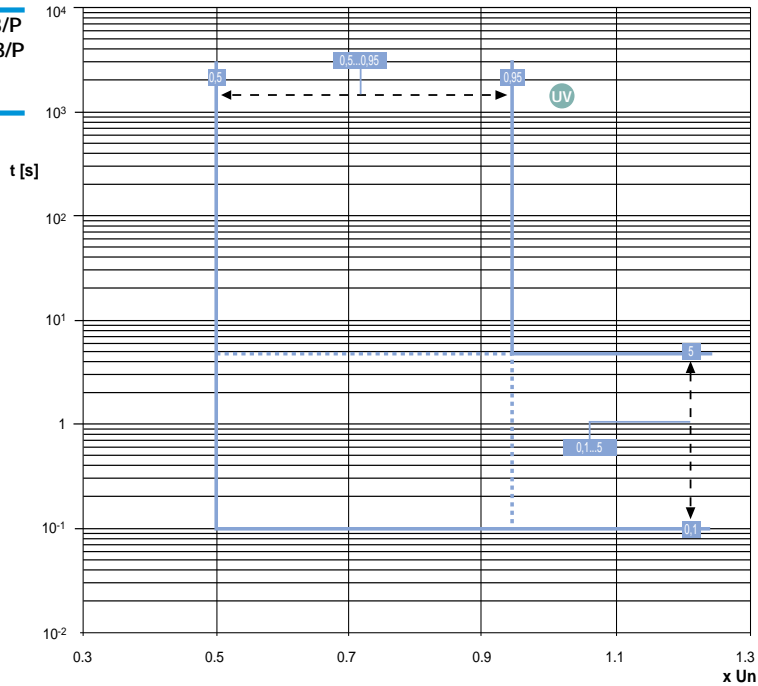

	<b>U8</b>	<b>t8</b>
PR122/P-PR123/P PR332/P-PR333/P	(0.5 ... 0.95 – OFF) x Un with step 0.01 x Un	with $U < U_B$ 0.1 ... 5s with step 0.1s
	Here below the tolerances:	
	<b>U8</b>	<b>t8</b>
PR122/P PR332/P-PR333/P	± 5 %	The better of two figures: ± 20 % or ± 100 ms
PR123/P	± 5 %	The better of two figures: ± 20 % or ± 40 ms

### 3 General characteristics

Trip curve  
electronic releases

**Emax**  
PR332/P\*-PR333/P  
PR122/P\*\*-PR123/P

**Tmax**  
PR332/P\*

Function OV  
\*with PR330/V  
\*\*with PR120/V

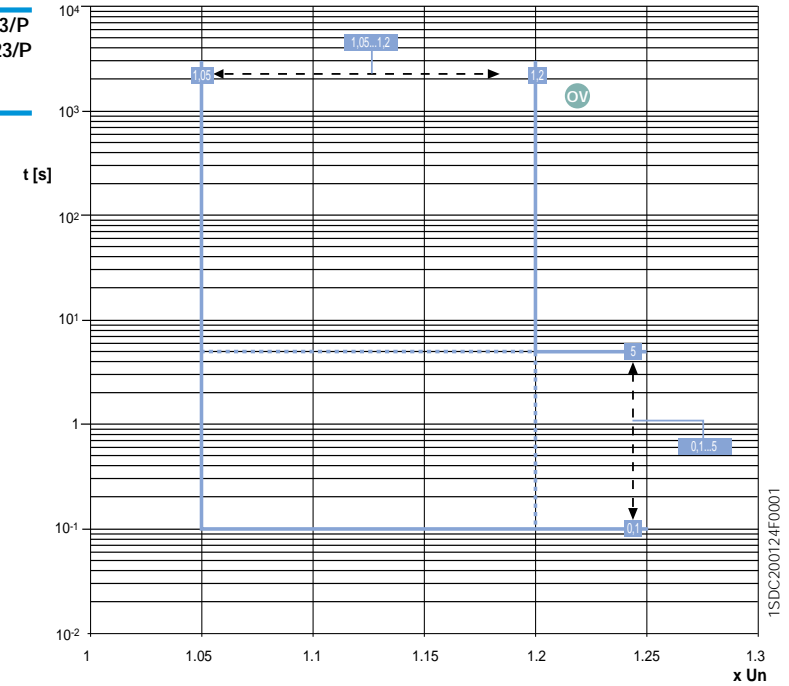

	<b>U9</b>	<b>t9</b>
PR122/P-PR123/P PR332/P-PR333/P	(1.05 ... 1.2 – OFF) x Un with step 0.01 x Un	with $U < U_B$ 0.1s ... 5s with step 0.1s
	Here below the tolerances:	
	<b>U9</b>	<b>t9</b>
PR122/P PR332/P-PR333/P	± 5 %	The better of two figures: ± 20 % or ± 100 ms
PR123/P	± 5 %	The better of two figures: ± 20 % or ± 40 ms

### 3 General characteristics

Trip curve  
electronic releases

**Emax**  
PR332/P\* -PR333/P  
PR122/P\*\* -PR123/P

**Tmax**  
PR332/P\*

Function RV  
\*with PR330/V  
\*\*with PR120/V

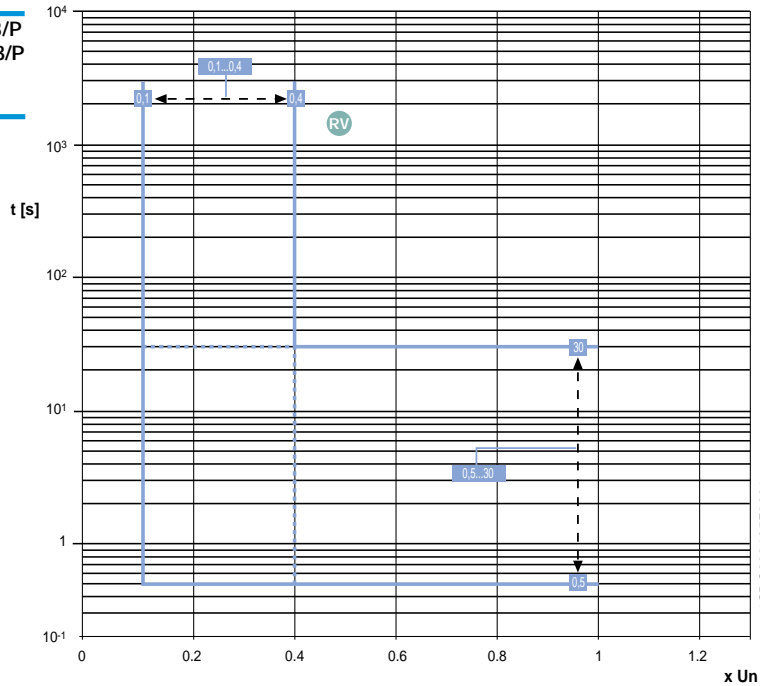

TSDC200125F0001

<b>U10</b>	<b>t10</b>
PR122/P PR123/P PR332/P PR333/P	with $U < U_{10}$
(0.1 ... 0.4 - OFF) x Un with step 0.05 x Un	0.5s ... 30s with step 0.5s
Here below the tolerances:	
<b>U10</b>	<b>t10</b>
PR122/P PR123/P PR332/P PR333/P	the better of the two figures:
± 5 %	± 10 % or ± 100 ms

### 3 General characteristics

Trip curve  
electronic releases

**Emax**  
PR332/P\* -PR333/P  
PR122/P\*\* -PR123/P

**Tmax**  
PR332/P\*

Function RP  
\*with PR330/V  
\*\*with PR120/V

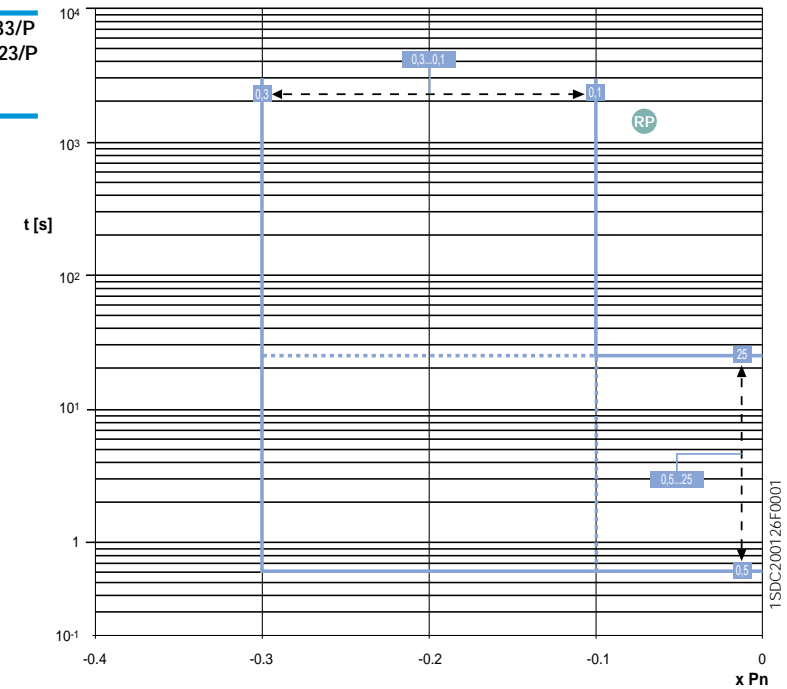

TSDC200126F0001

<b>P11</b>	<b>t11</b>
PR122/P PR123/P	with $P < P_{11}$
(-0.3 ... -0.1 - OFF) x Pn with step 0.02 x Pn	0.1 ... 25s with step 0.1s
Here below the tolerances:	
<b>P11</b>	<b>t11</b>
PR122/P-PR332/P PR123/P-PR333/P	the better of the two figures:
± 5 %	± 10 % or ± 100 ms
10 %	

### 3 General characteristics

#### Example of electronic release setting

Considering a circuit-breaker type E1B1000 fitted with a PR121/P LSI release and with a rating plugs of 1000, it is supposed that for the system requirements, the protection functions are regulated according to the following settings:

L	$I1=0.6$	$t1=12s$
S	$I2=4$	$t2=0.3$
I	$I3=8$	

The trip curve of the release is represented in the following figure (continuous lines): it can be seen that:

- for function L, the curve is represented by the mean value between the tolerances given by the Standard (the overload protection function must not trip for current values lower than  $1.05 \cdot I_n$ , and must trip within  $1.3 \cdot I_n$ , therefore corresponding to  $1.175 \cdot I_n$  (around 700 A);
- graphically, point **1** is obtained at the intersection of the vertical part of function L and the horizontal segment ( $C_{0.4I_n}$ - $C_{1I_n}$ ) which connects the points relevant to the same  $t1$ , taken from the curves with setting  $0.4 \cdot I_n$  and  $1 \cdot I_n$ ;
- corresponding to point **2** (4000 A), the function S takes the place of function L, as the trip time of function S is lower than the trip time of function L;
- in the same way as for point **2**, for point **3** (8000 A) and beyond, function S is substituted by function I.

### 3 General characteristics

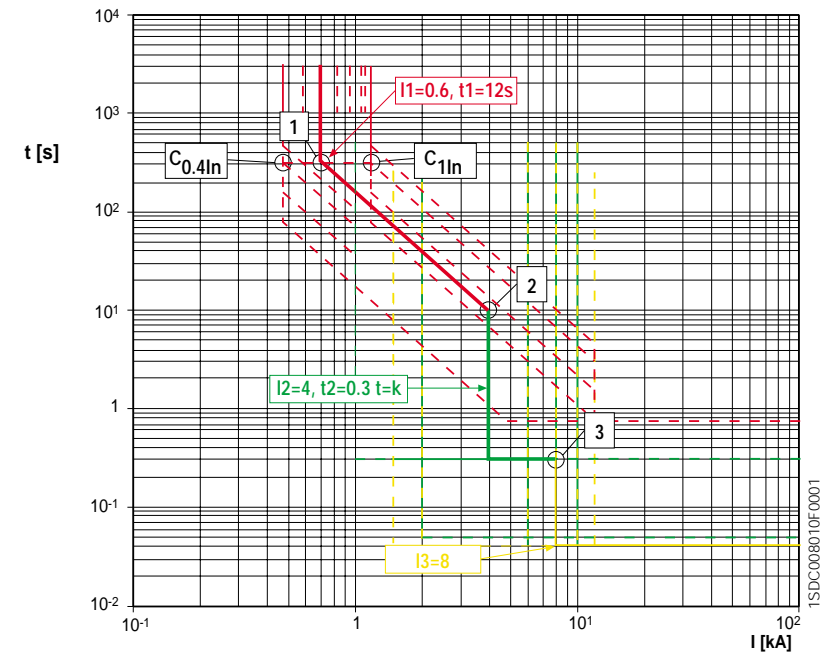

### 3 General characteristics

#### 3.3 Limitation curves

A circuit-breaker in which the opening of the contacts occurs after the passage of the peak of the short-circuit current, or in which the trip occurs with the natural passage to zero, allows the system components to be subjected to high stresses, of both thermal and dynamic type. To reduce these stresses, current-limiting circuit-breakers have been designed (see Chapter 2.2 "Main definitions"), which are able to start the opening operation before the short-circuit current has reached its first peak, and to quickly extinguish the arc between the contacts; the following diagram shows the shape of the waves of both the prospective short-circuit current as well as of the limited short-circuit current.

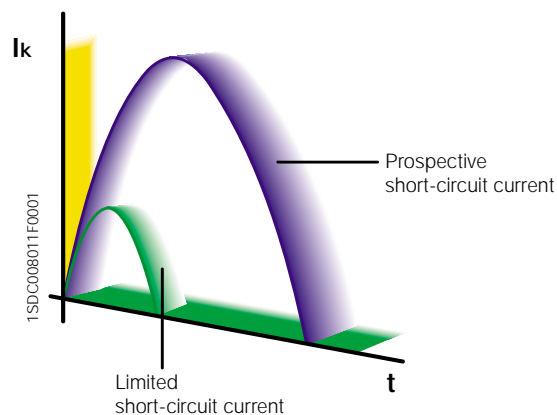

The following diagram shows the limit curve for Tmax T2L160, In160 circuit-breaker. The x-axis shows the effective values of the symmetrical prospective short-circuit current, while the y-axis shows the relative peak value. The limiting effect can be evaluated by comparing, at equal values of symmetrical fault current, the peak value corresponding to the prospective short-circuit current (curve A) with the limited peak value (curve B).

### 3 General characteristics

Circuit-breaker T2L160 with thermomagnetic release In160 at 400 V, for a fault current of 40 kA, limits the short-circuit peak to 16.2 kA only, with a reduction of about 68 kA compared with the peak value in the absence of limitation (84 kA).

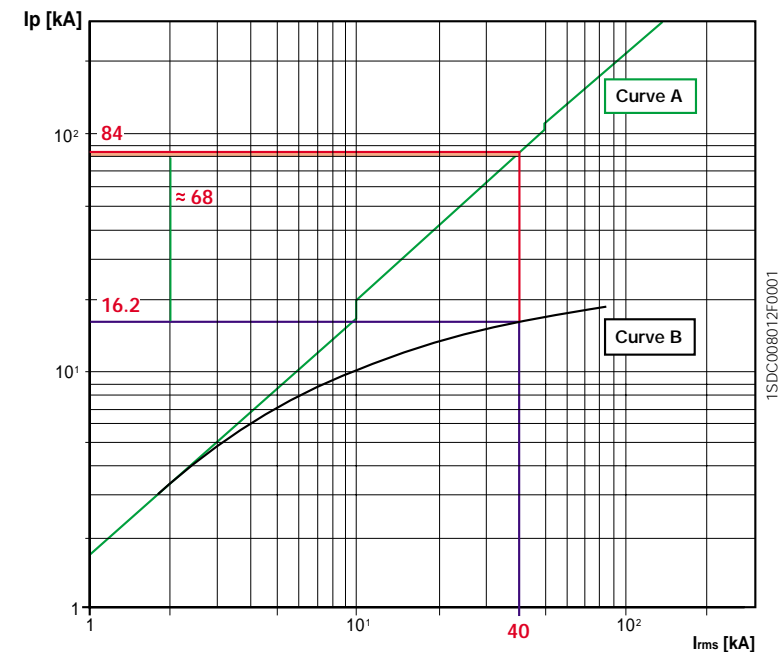

Considering that the electro-dynamic stresses and the consequent mechanical stresses are closely connected to the current peak, the use of current limiting circuit-breakers allows optimum dimensioning of the components in an electrical plant. Besides, current limitation may also be used to obtain back-up protection between two circuit-breakers in series.

In addition to the advantages in terms of design, the use of current-limiting

### 3 General characteristics

circuit-breakers allows, for the cases detailed by Standard IEC 60439-1, the avoidance of short-circuit withstand verifications for switchboards. Clause 8.2.3.1 of the Standard "Circuits of ASSEMBLIES which are exempted from the verification of the short-circuit withstand strength" states that:

"A verification of the short-circuit withstand strength is not required in the following cases...

For ASSEMBLIES protected by current-limiting devices having a cut-off current not exceeding 17 kA at the maximum allowable prospective short-circuit current at the terminals of the incoming circuit of the ASSEMBLY..."

The example in the previous page included among those considered by the Standard: if the circuit-breaker was used as a main breaker in a switchboard to be installed in a point of the plant where the prospective short-circuit current is 40 kA, it would not be necessary to carry out the verification of short-circuit withstand.

### 3 General characteristics

Limitation curves

**T1 160**

230 V

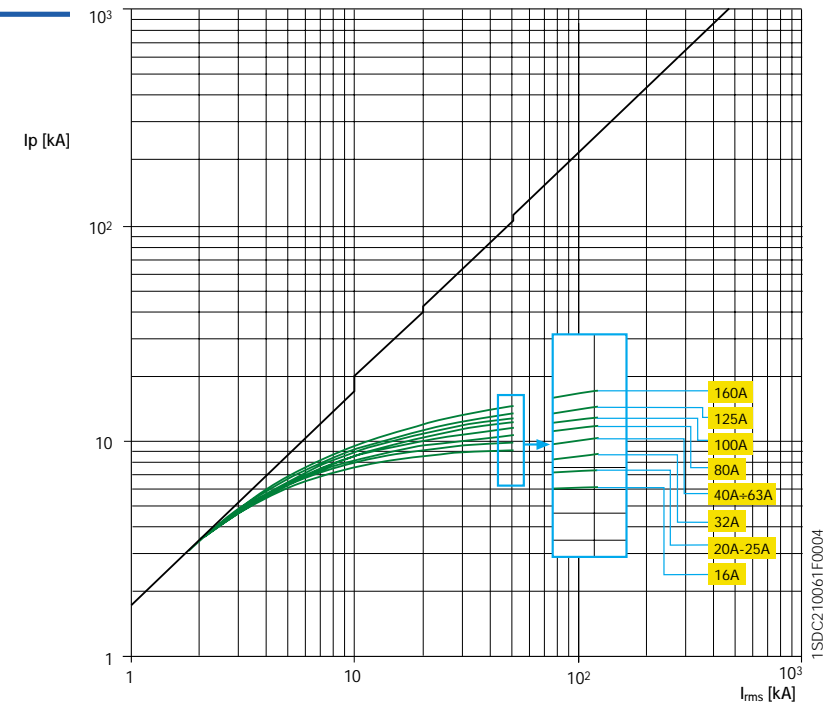

### 3 General characteristics

Limitation curves

#### T2 160

230 V

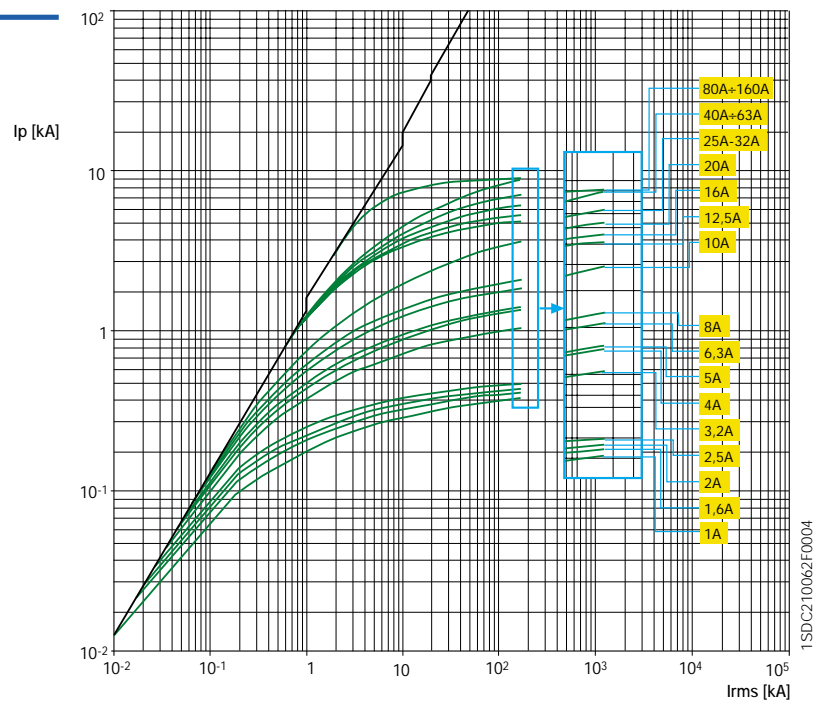

### 3 General characteristics

Limitation curves

#### T3 250

230 V

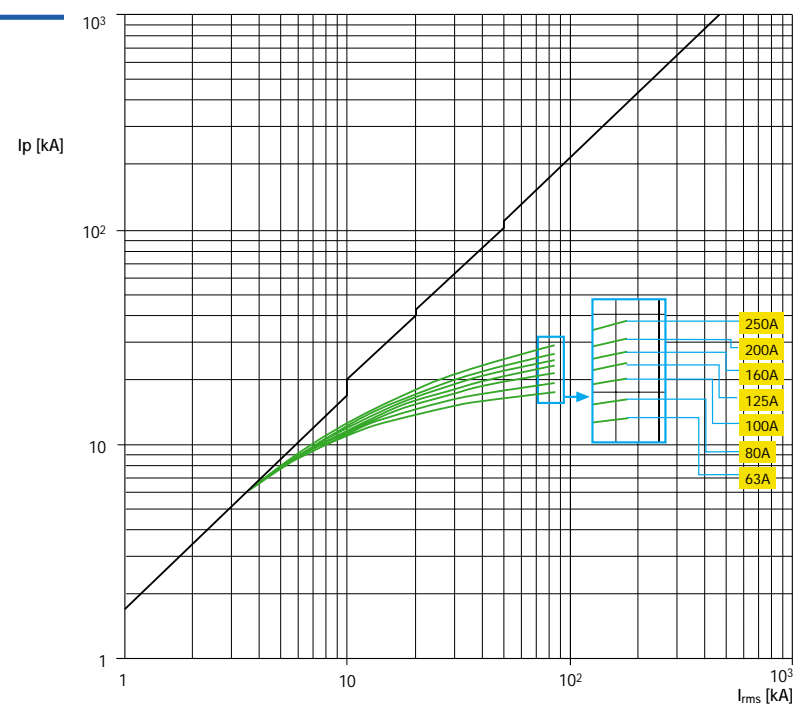

### 3 General characteristics

Limitation curves

**T4 250/320**

230 V

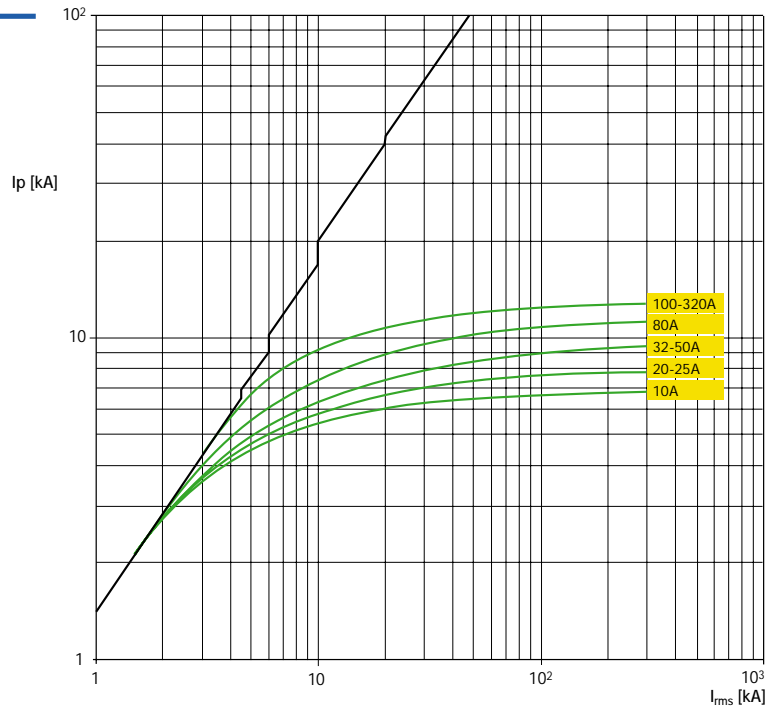

1SDC200127F0001

### 3 General characteristics

Limitation curves

**T5 400/630**

230 V

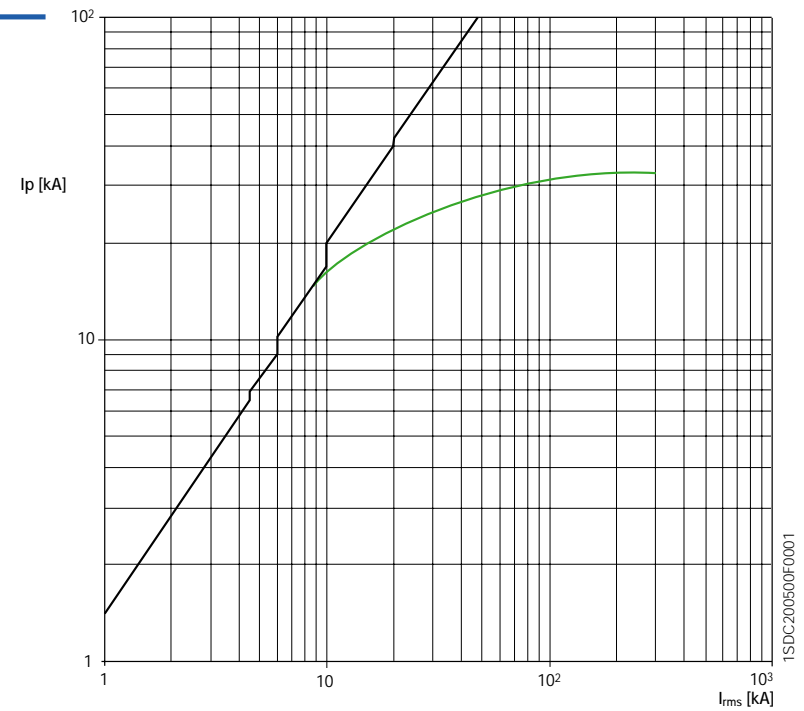

1SDC200500F0001

### 3 General characteristics

Limitation curves  
**T6 630/800/1000**  
 230 V

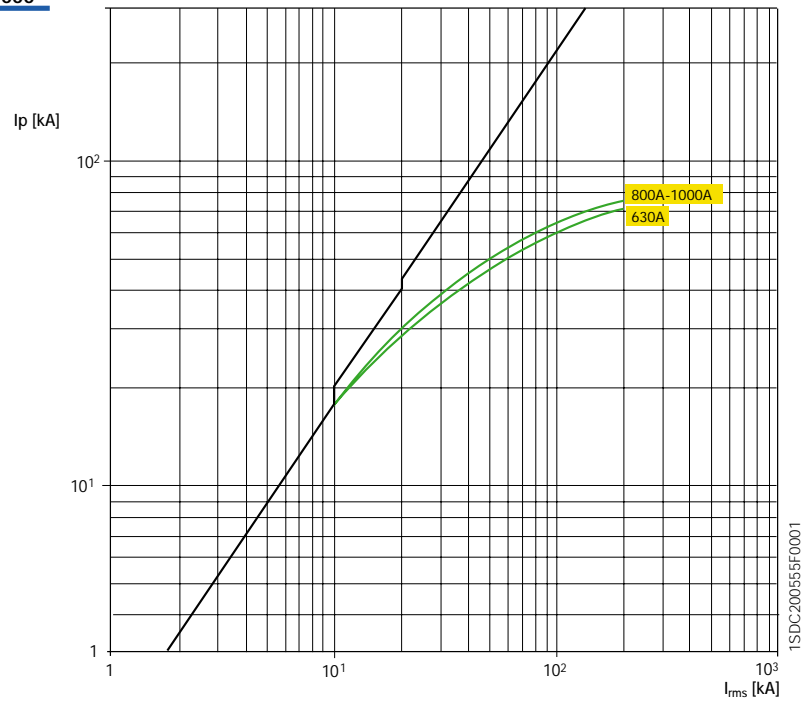

### 3 General characteristics

Limitation curves  
**T7 800/1000/1250/1600**  
 230 V

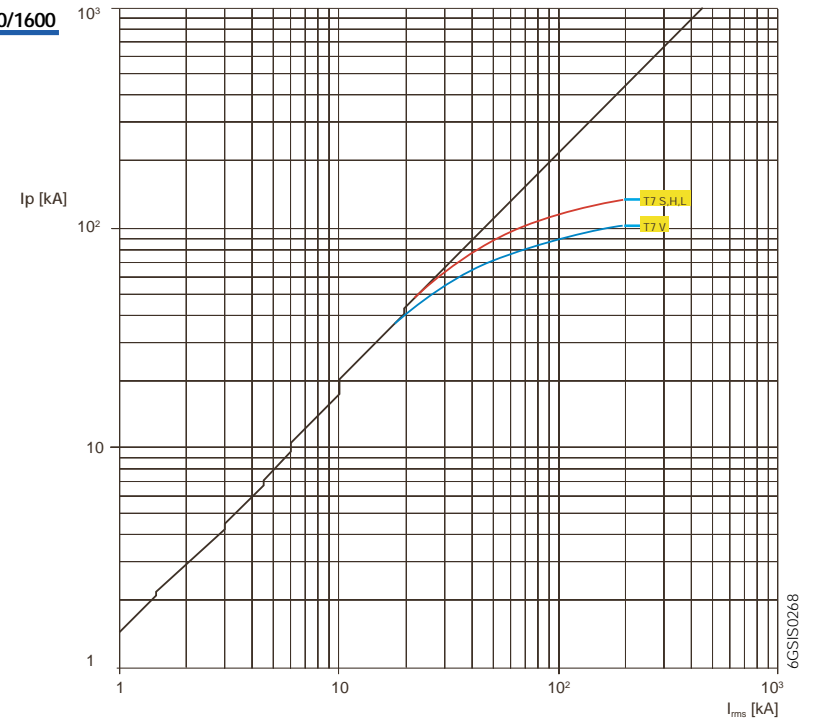



### 3 General characteristics

Limitation curves

#### T1 160

400-440 V

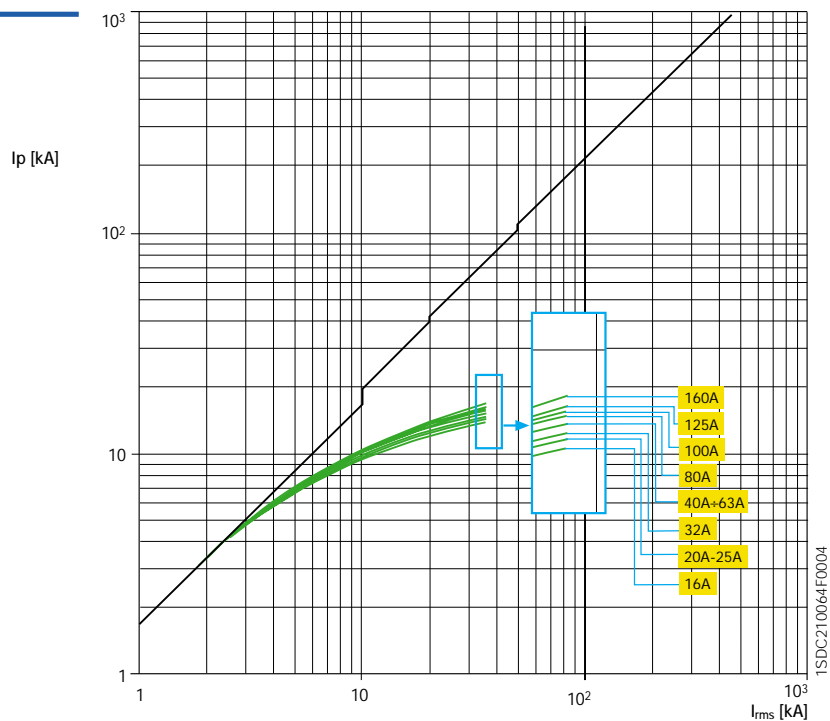

### 3 General characteristics

Limitation curves

#### T2 160

400-440 V

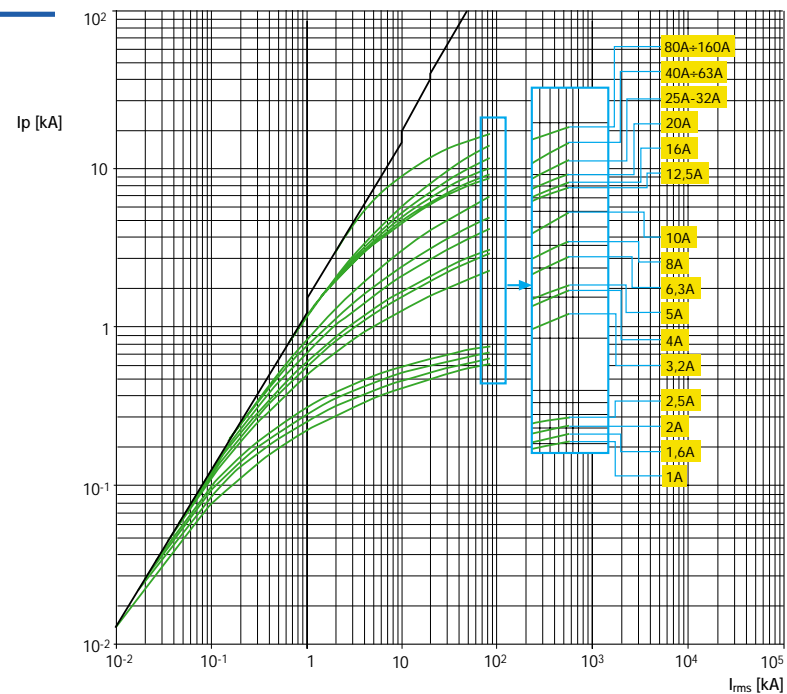

### 3 General characteristics

Limitation curves

#### T3 250

400-440 V

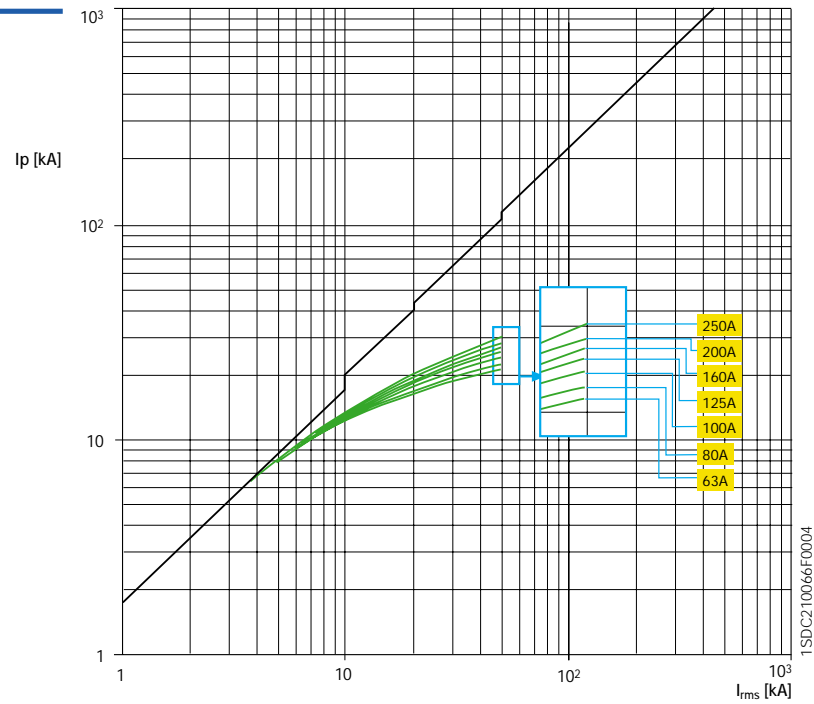

### 3 General characteristics

Limitation curves

#### T4 250/320

400-440 V

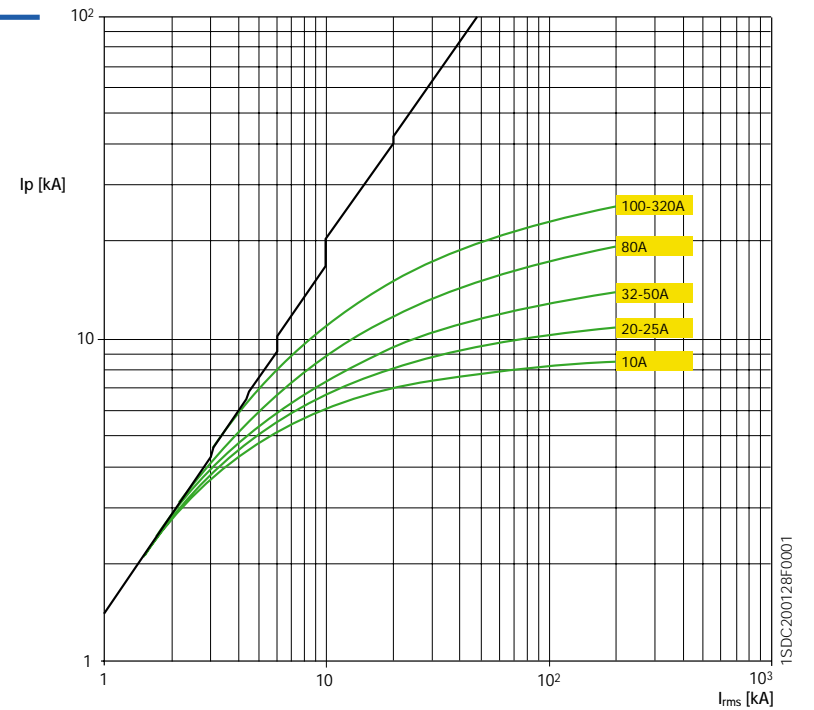

### 3 General characteristics

Limitation curves

#### **T5 400/630**

400-440 V

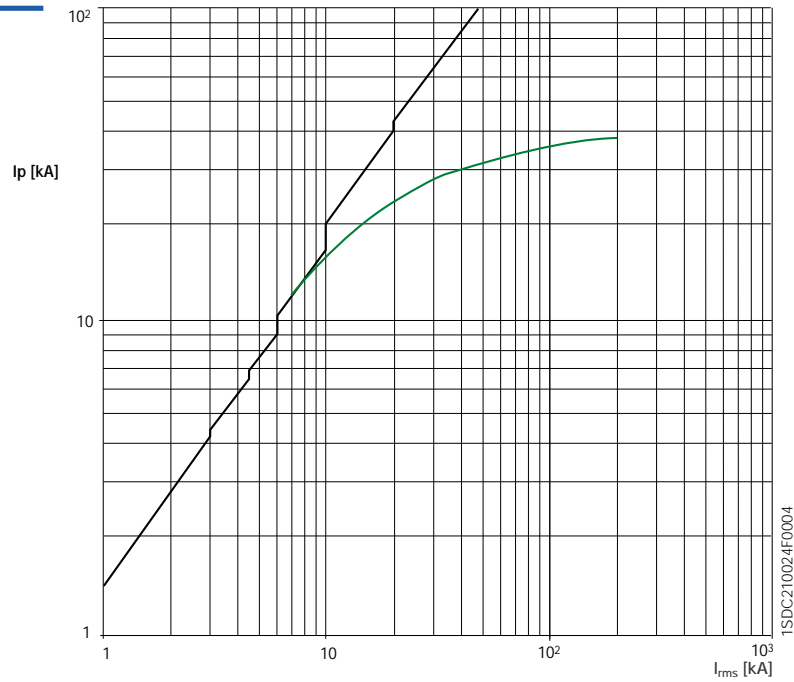

### 3 General characteristics

Limitation curves

#### **T6 630/800/1000**

400-440 V

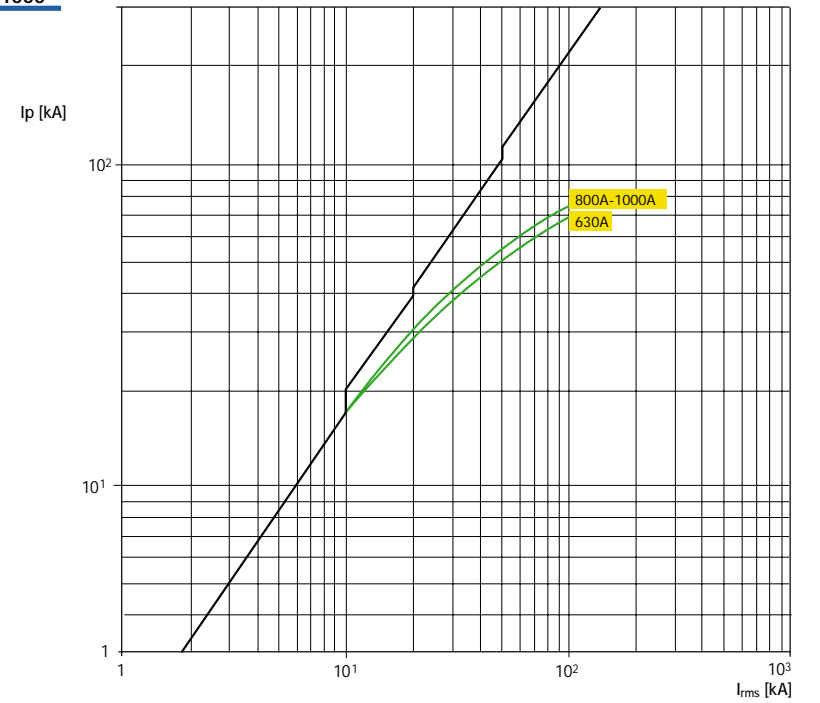

### 3 General characteristics

Limitation curves

**T7**  
800/1000/1250/1600

400-440 V

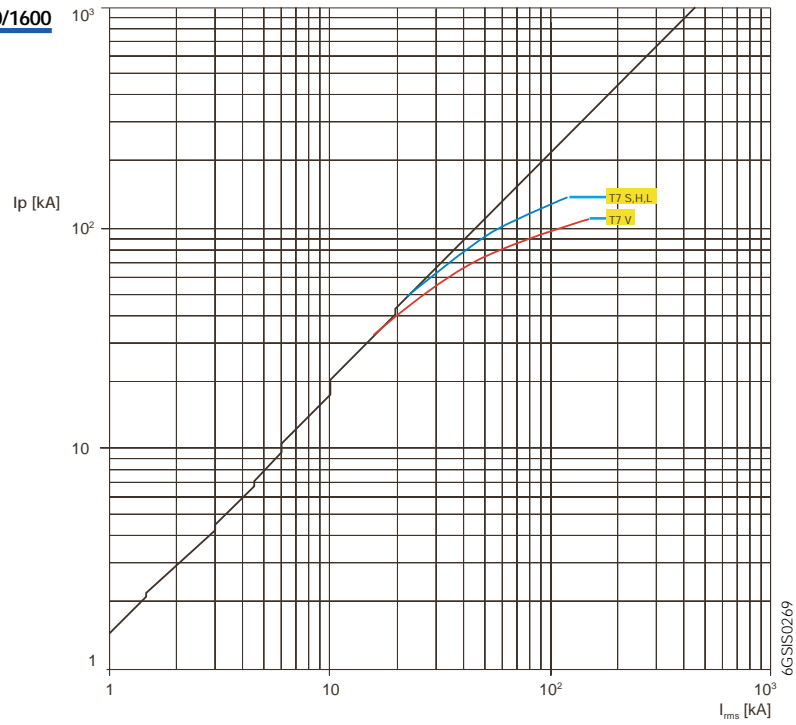

6GSS0269

### 3 General characteristics

Limitation curves

**T1 160**

500 V

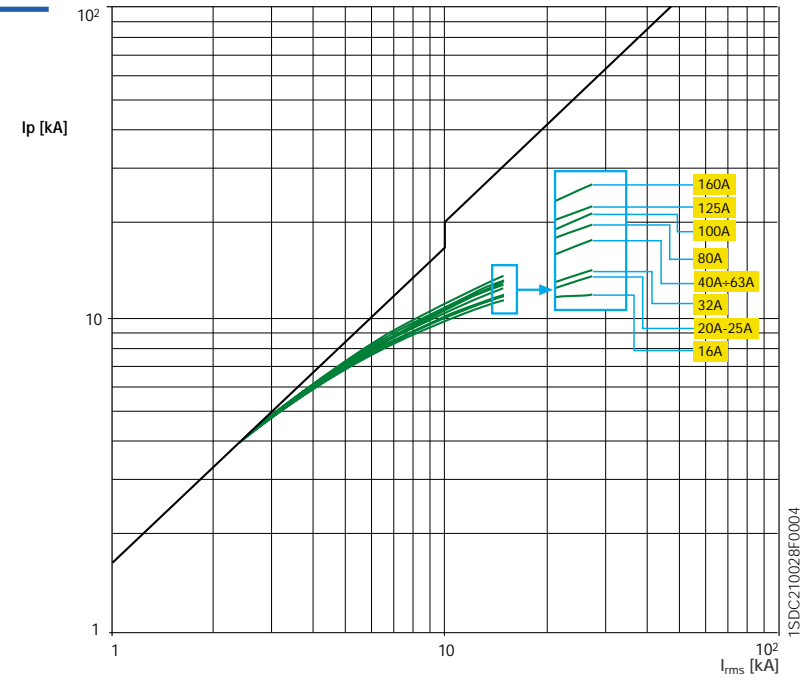

1SDC210028F0004

### 3 General characteristics

Limitation curves

#### T2 160

500 V

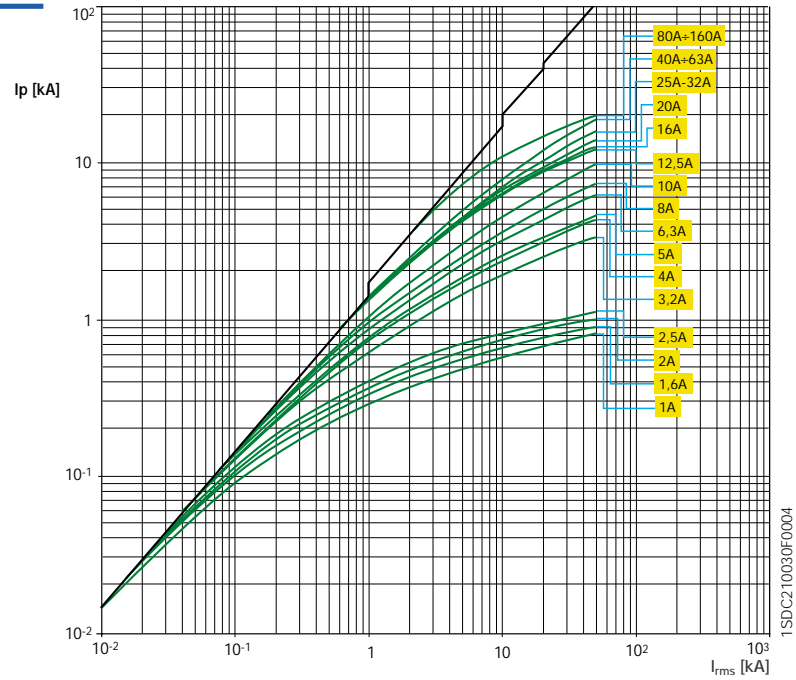

1SDC210030F0004

### 3 General characteristics

Limitation curves

#### T3 250

500 V

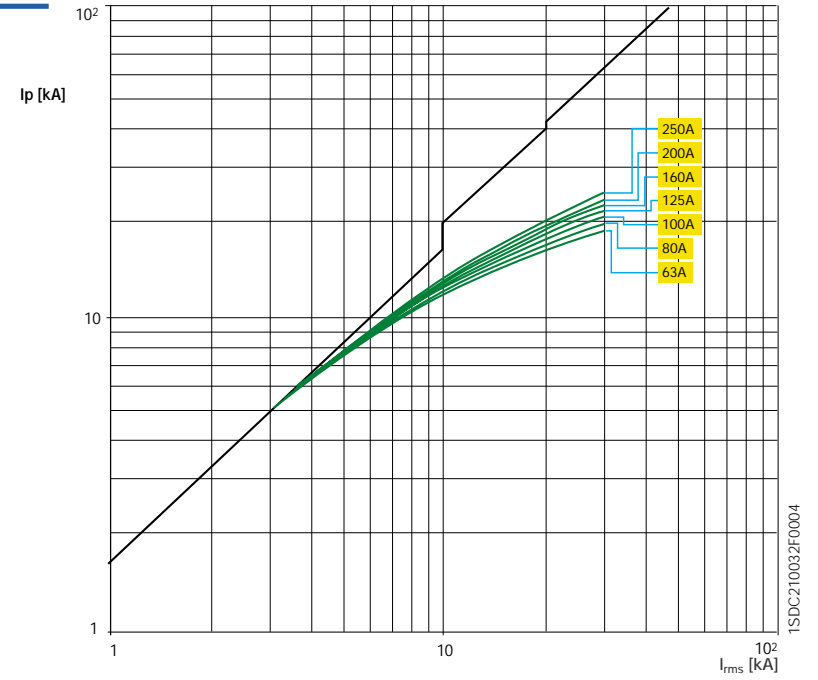

1SDC210032F0004

### 3 General characteristics

Limitation curves

**T4 250/320**

500 V

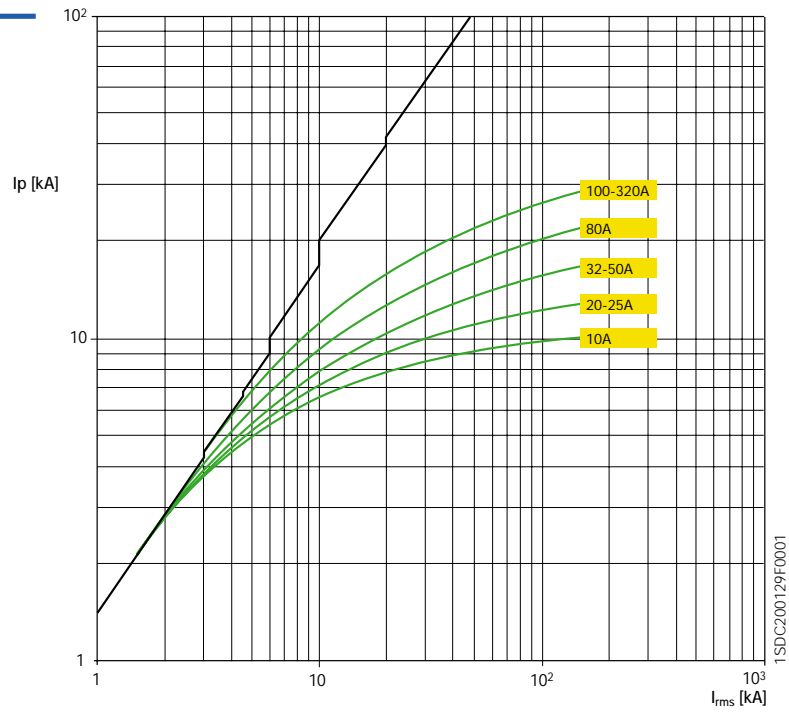

### 3 General characteristics

Limitation curves

**T5 400/630**

500 V

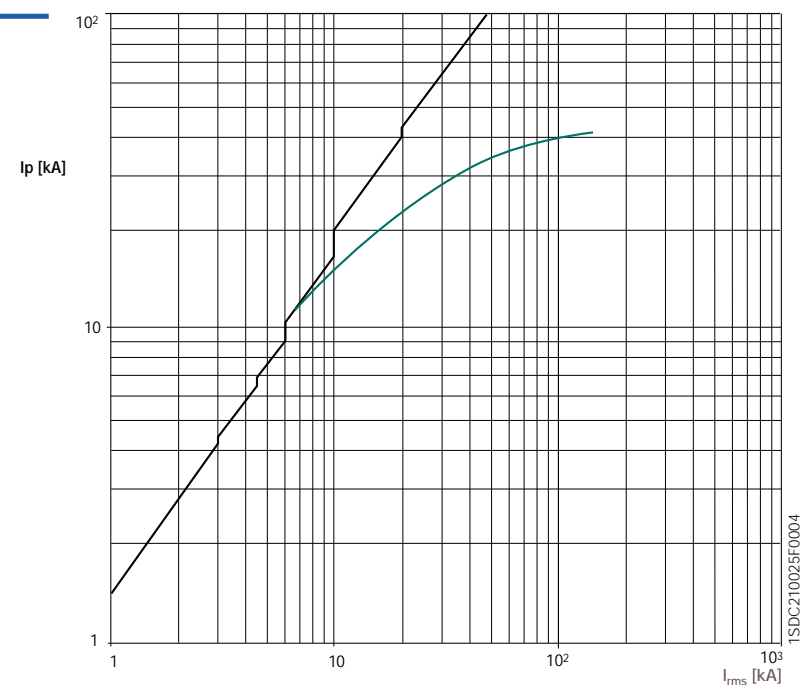

### 3 General characteristics

Limitation curves

**T6 630/800/1000**

500 V

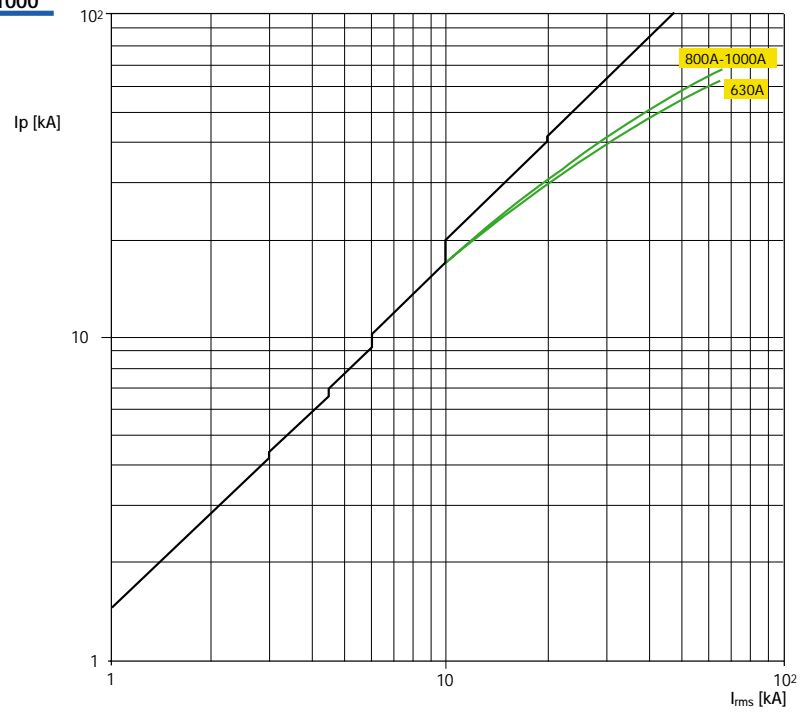

### 3 General characteristics

Limitation curves

**T7 800/1000/1250/1600**

500 V

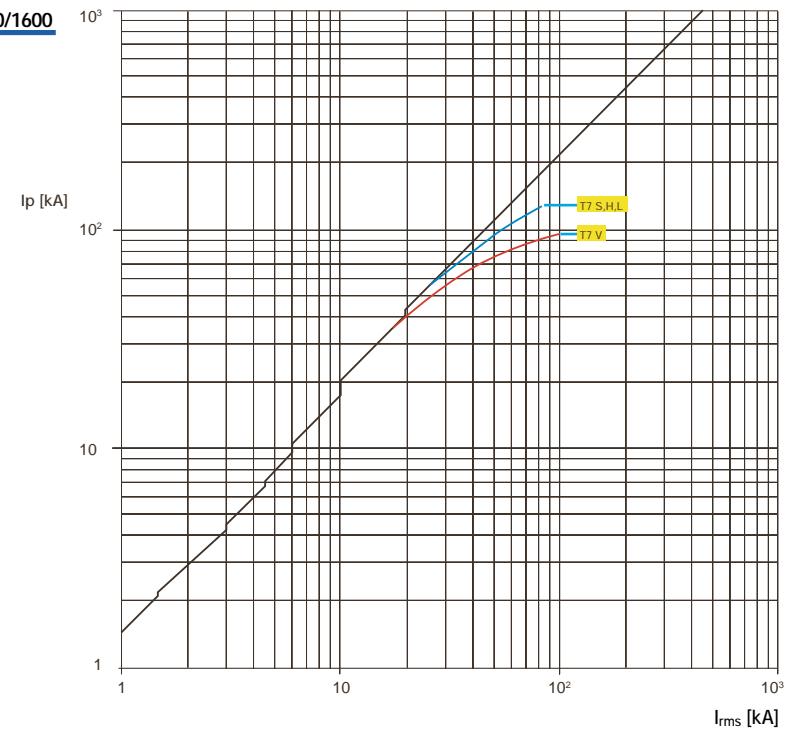

### 3 General characteristics

Limitation curves

#### T1 160

690 V

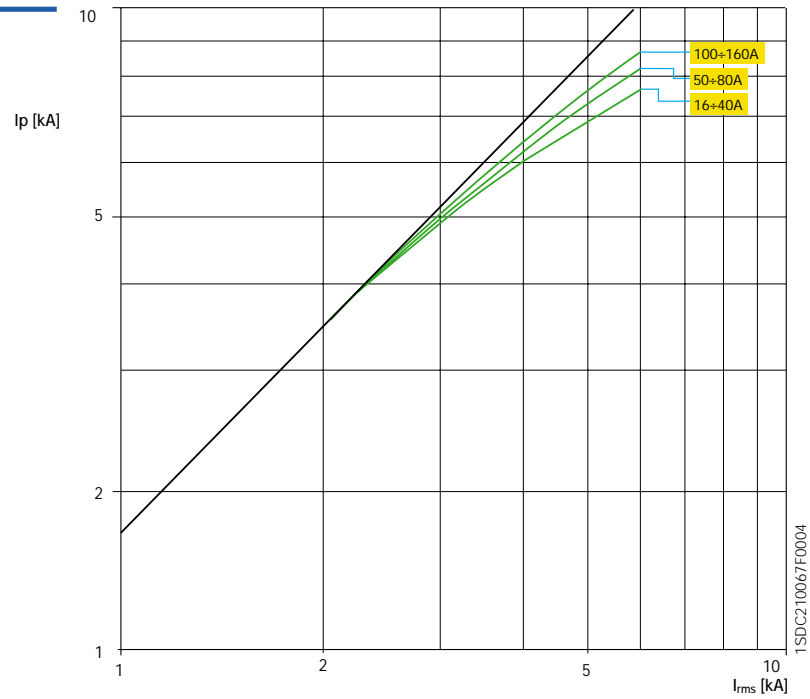

### 3 General characteristics

Limitation curves

#### T2 160

690 V

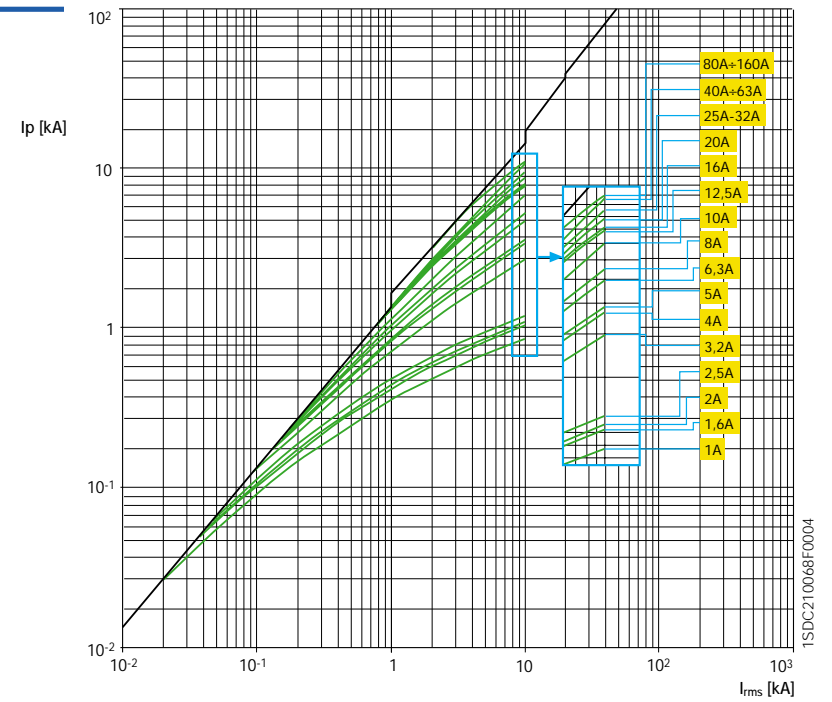



### 3 General characteristics

Limitation curves

**T3 250**

690 V

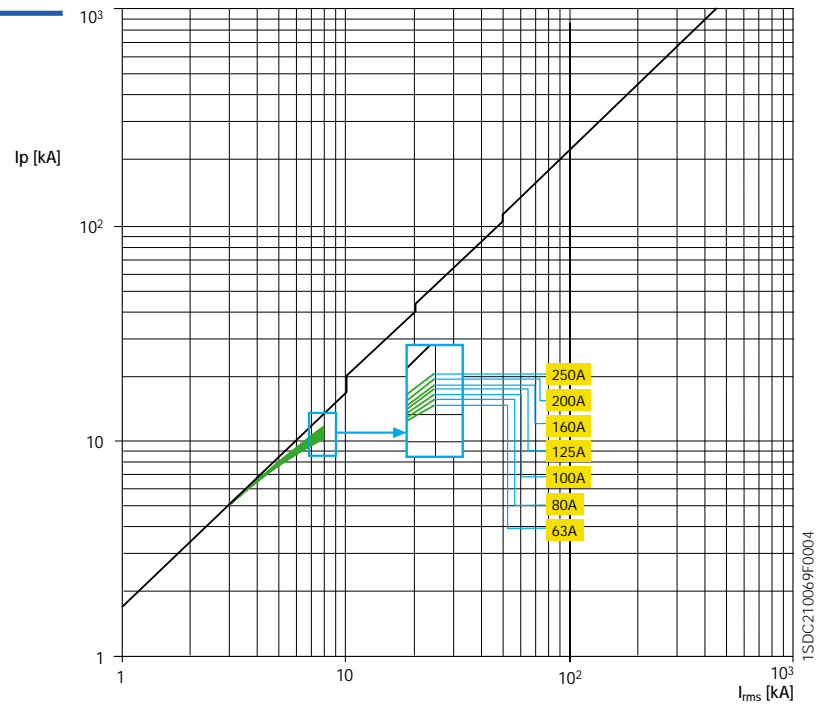

### 3 General characteristics

Limitation curves

**T4 250/320**

690 V

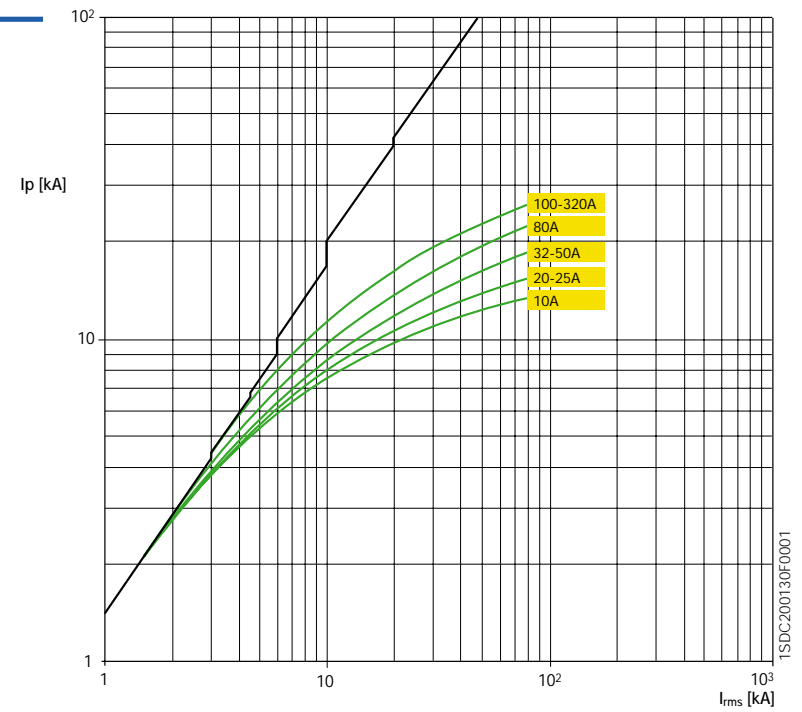

### 3 General characteristics

Limitation curves

**T5 400/630**

690 V

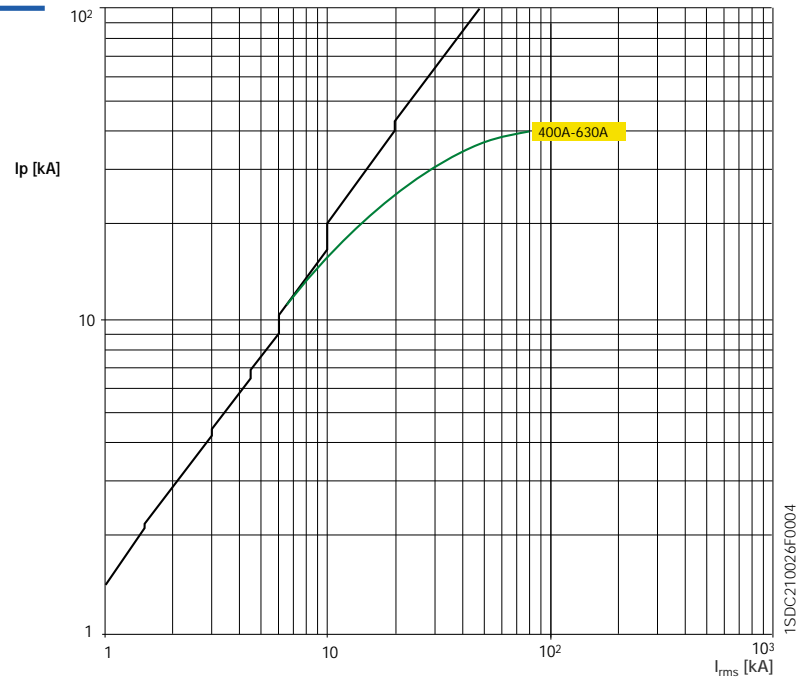

### 3 General characteristics

Limitation curves

**T6 630/800/1000**

690 V

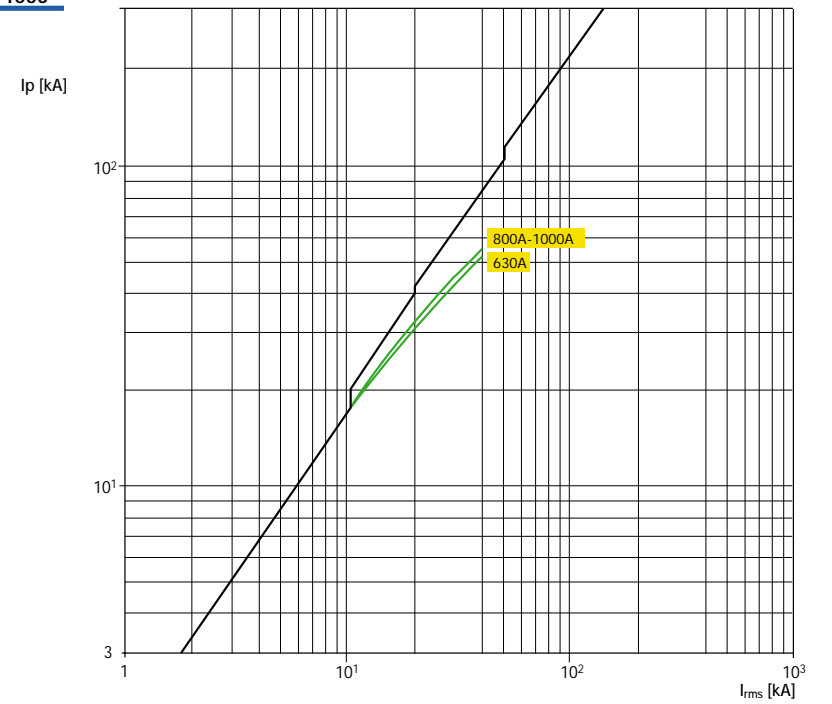

### 3 General characteristics

Limitation curves

**T7**  
**800/1000/1250/1600**

690 V

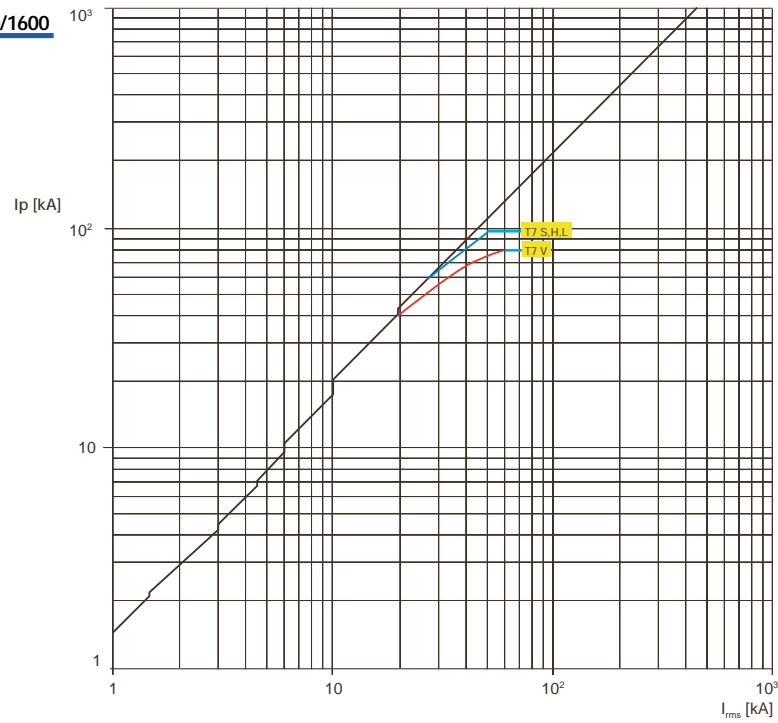

### 3 General characteristics

Limitation curves

**T4 250**  
**T5 400/630**

1000 V

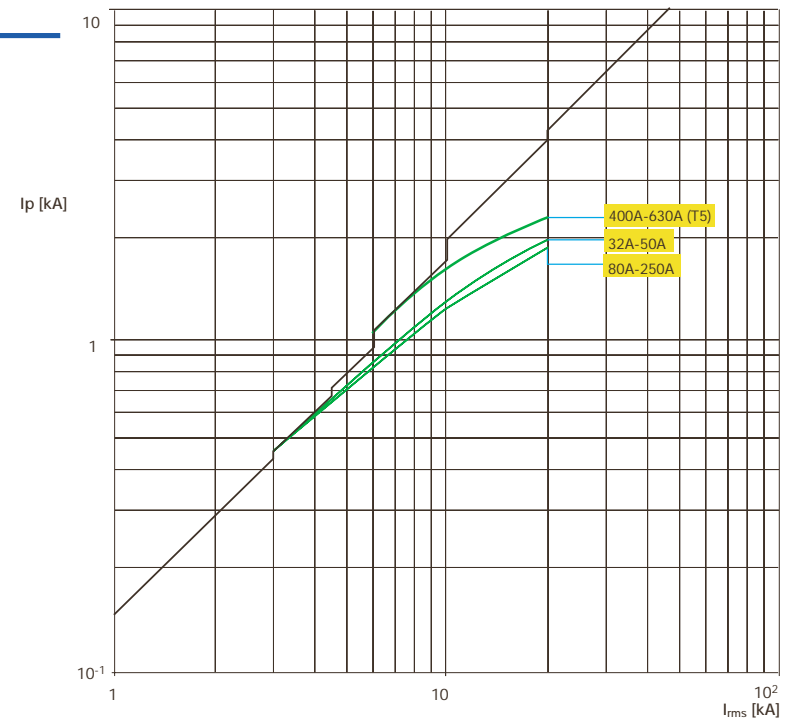

### 3 General characteristics

Limitation curves

**S7**

230 V

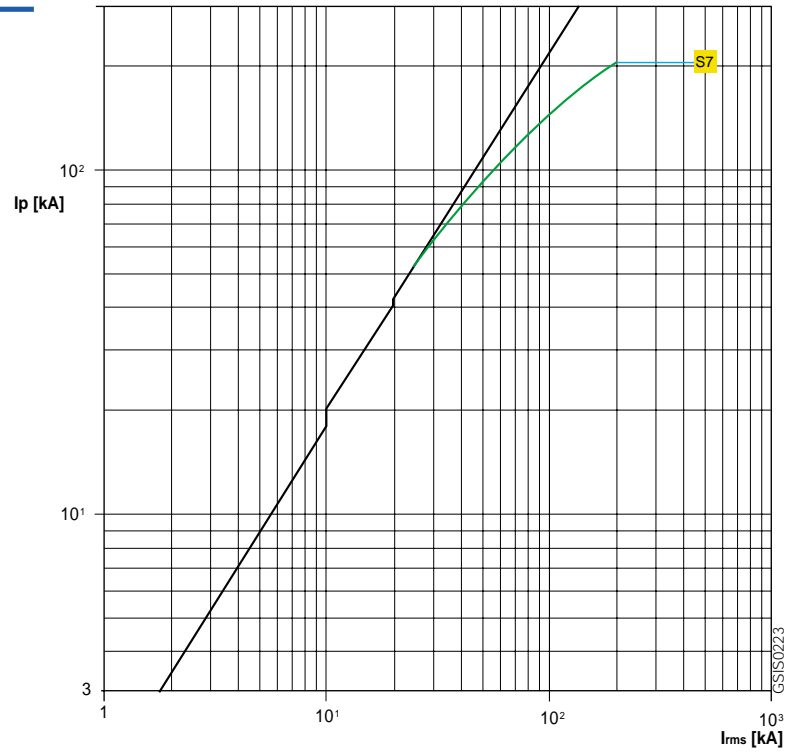

### 3 General characteristics

Limitation curves

**S7**

400-440 V

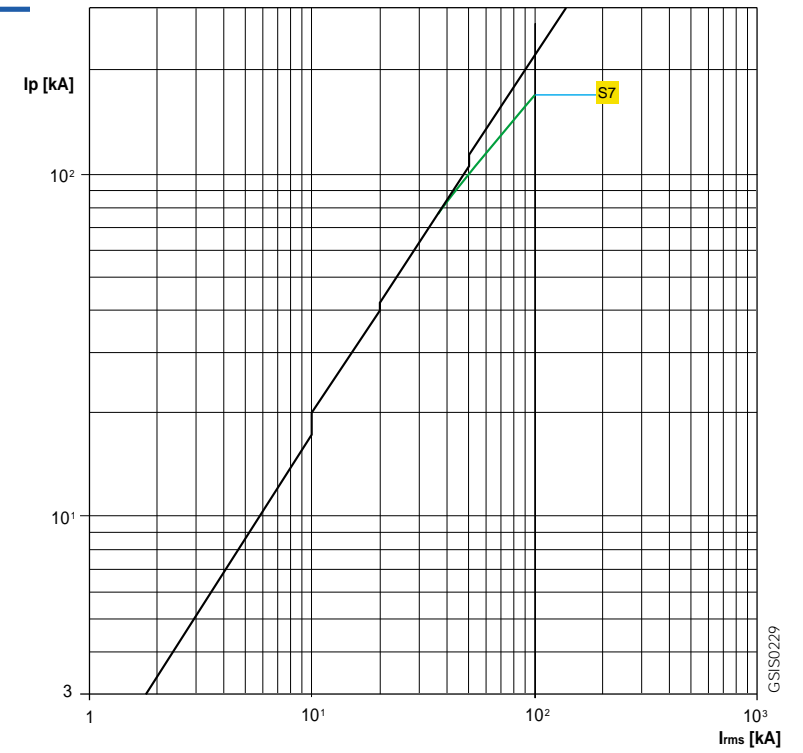

### 3 General characteristics

Limitation curves

**S7**

690 V

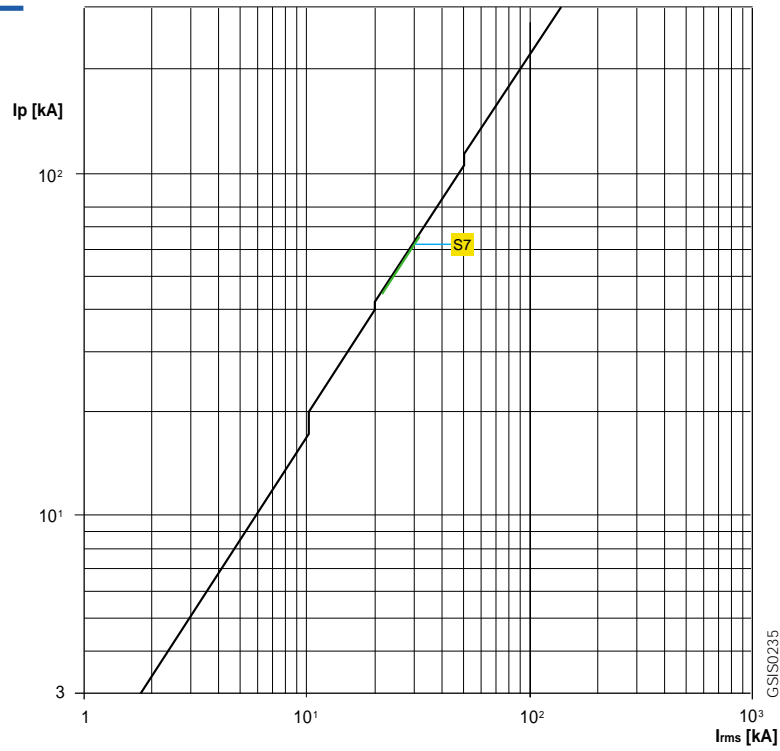

### 3 General characteristics

Limitation curves

**X1L**

690 V ~  
380/415 V ~

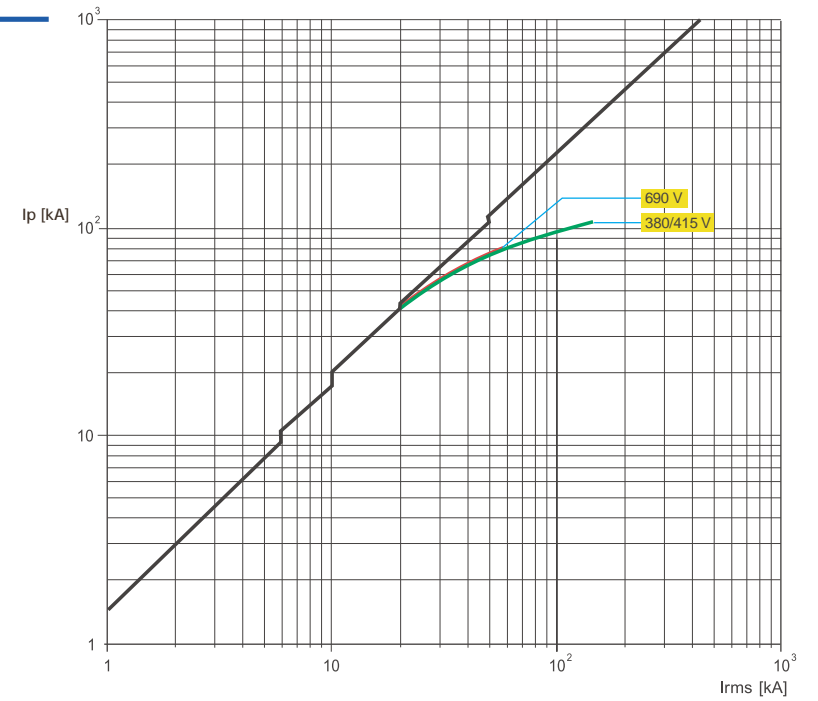

### 3 General characteristics

Limitation curves

#### E2L

690 V ~  
380/415 V ~

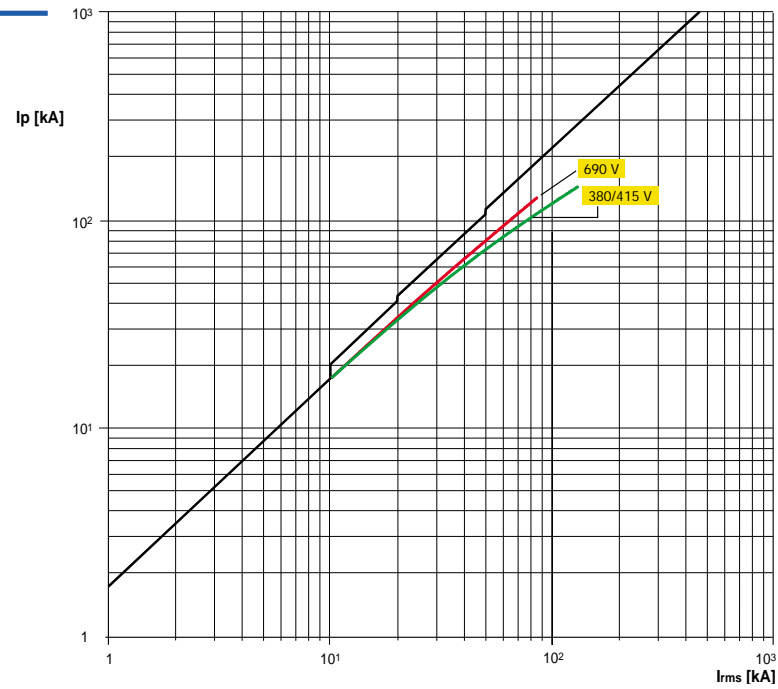

15DC200092F0001

### 3 General characteristics

Limitation curves

#### E3L

690 V ~  
380/415 V ~

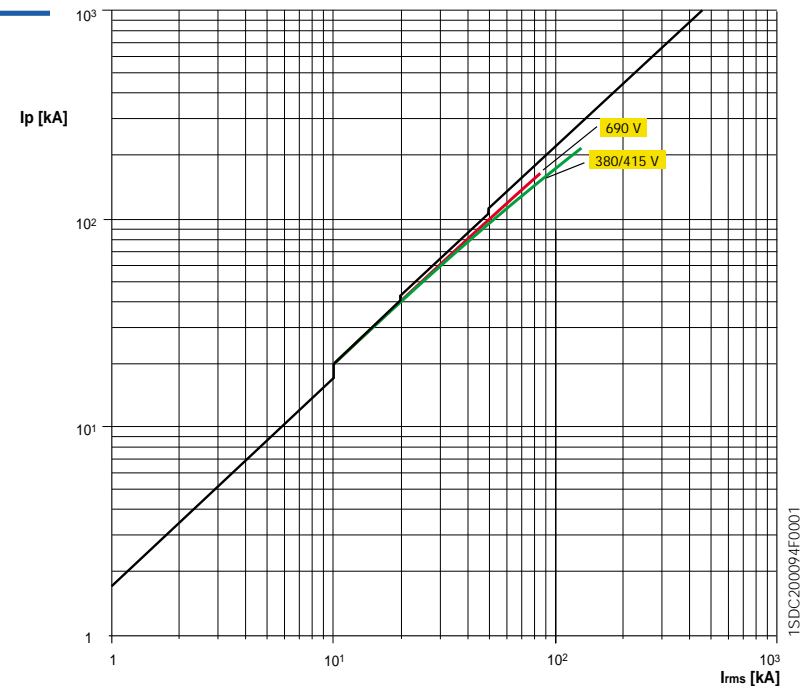

15DC200094F0001

### 3 General characteristics

#### 3.4 Specific let-through energy curves

In case of short-circuit, the parts of a plant affected by a fault are subjected to thermal stresses which are proportional both to the square of the fault current as well as to the time required by the protection device to break the current. The energy let through by the protection device during the trip is termed "specific let-through energy" ( $I^2t$ ), measured in  $A^2s$ . The knowledge of the value of the specific let-through energy in various fault conditions is fundamental for the dimensioning and the protection of the various parts of the installation. The effect of limitation and the reduced trip times influence the value of the specific let-through energy. For those current values for which the tripping of the circuit-breaker is regulated by the timing of the release, the value of the specific let-through energy is obtained by multiplying the square of the effective fault current by the time required for the protection device to trip; in other cases the value of the specific let-through energy may be obtained from the following diagrams.

The following is an example of the reading from a diagram of the specific let-through energy curve for a circuit-breaker type T3S 250 In160 at 400 V. The x-axis shows the symmetrical prospective short-circuit current, while the y-axis shows the specific let-through energy values, expressed in  $MA^2s$ . Corresponding to a short-circuit current equal to 20 kA, the circuit-breaker lets through a value of  $I^2t$  equal to 1.17  $MA^2s$  (1170000  $A^2s$ ).

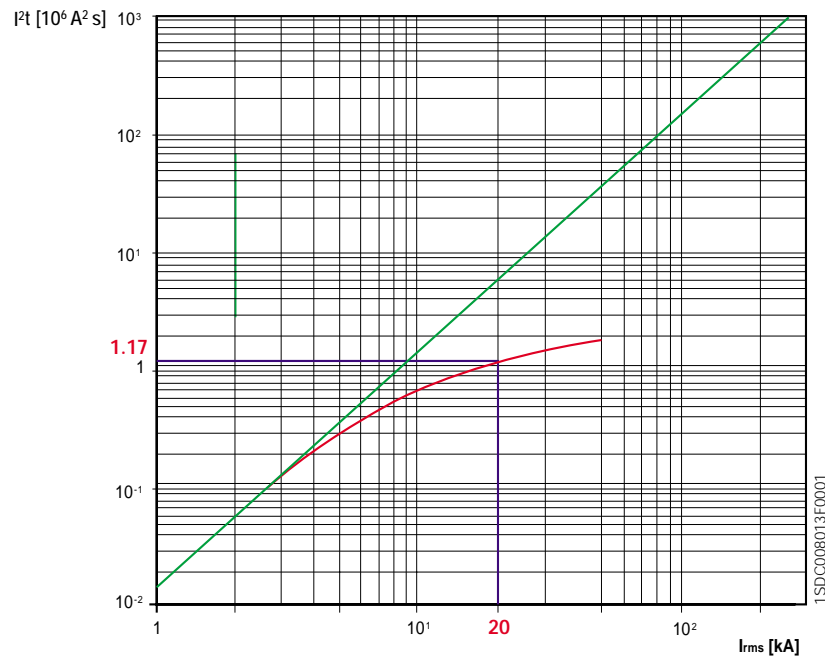

### 3 General characteristics

Specific let-through energy curves

#### T1 160

230 V

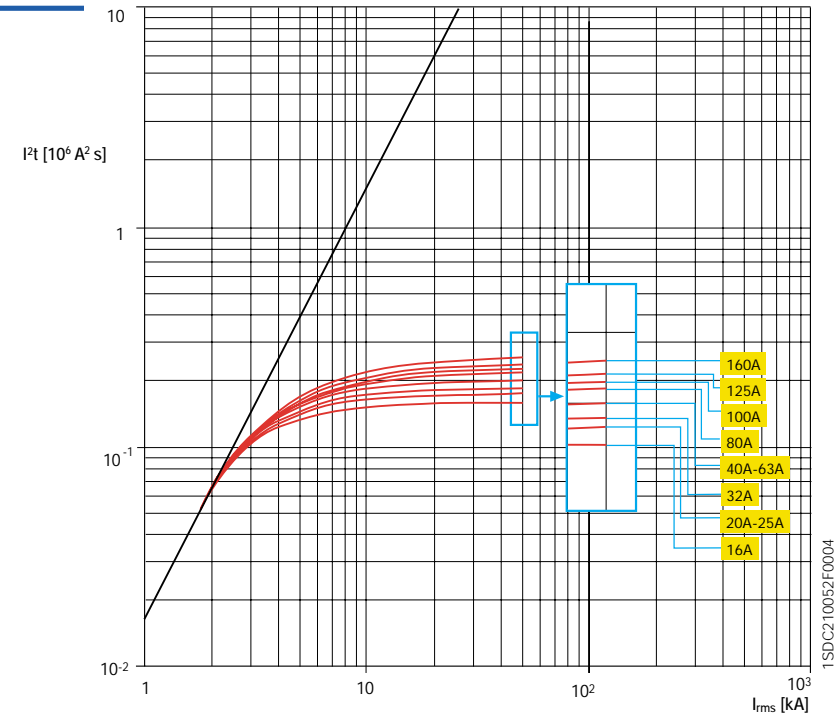

### 3 General characteristics

Specific let-through energy curves

#### T2 160

230 V

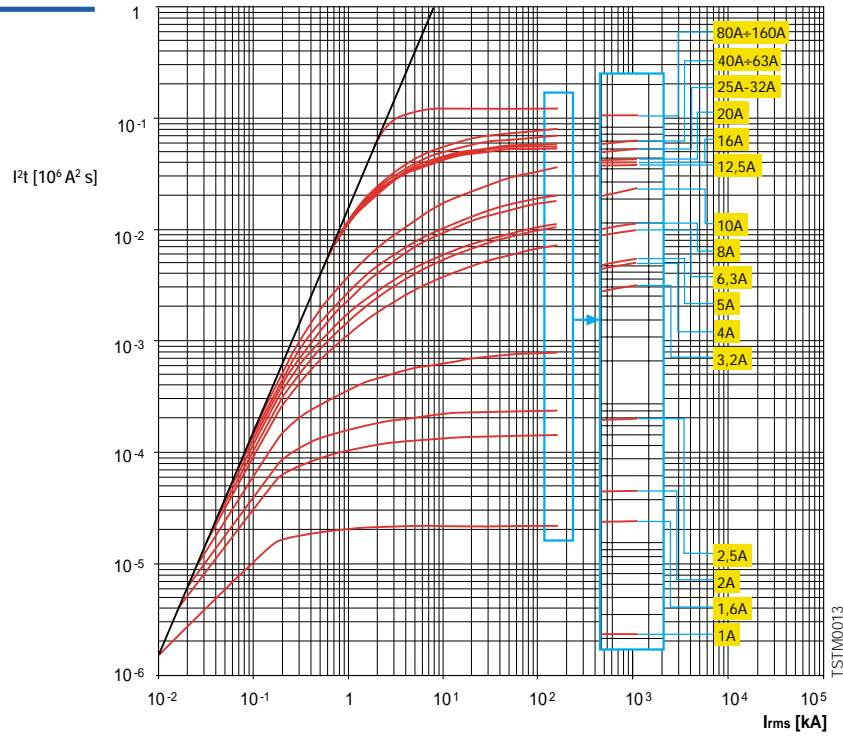

TSTM0013

### 3 General characteristics

Specific let-through energy curves

#### T3 250

230 V

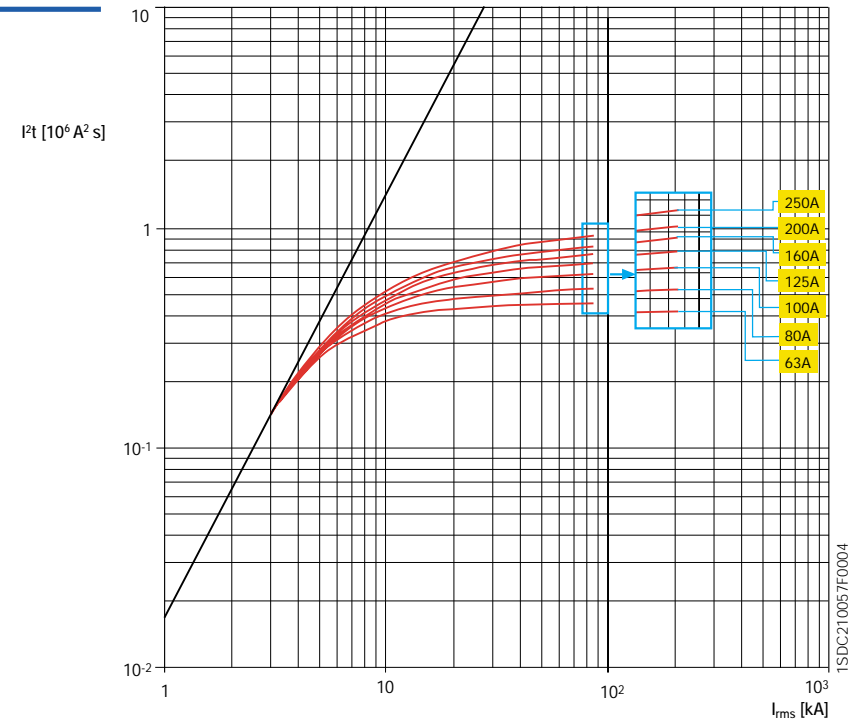

1SDC210057F0004



### 3 General characteristics

Specific let-through energy curves

#### T4 250/320

230 V

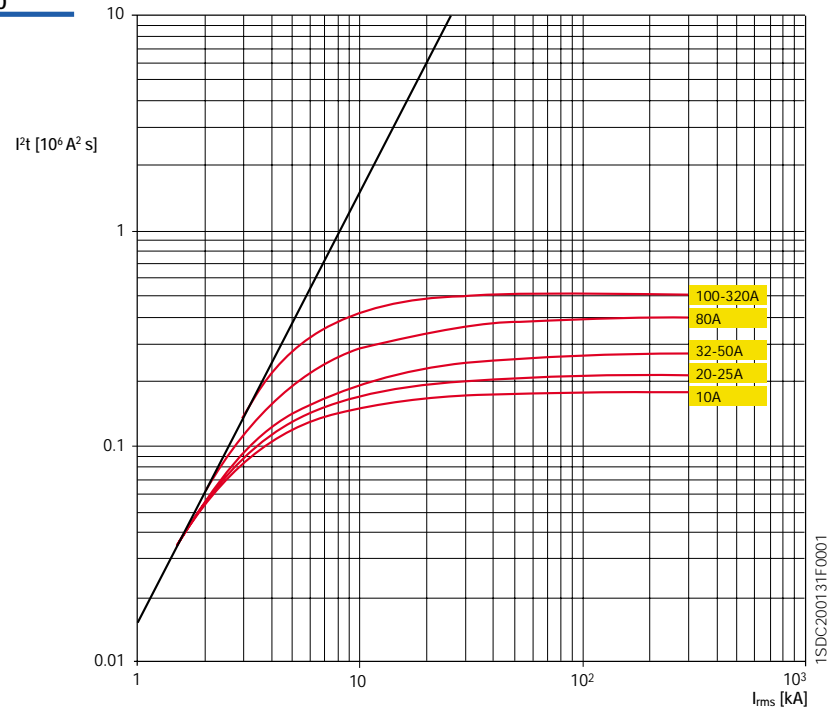

### 3 General characteristics

Specific let-through energy curves

#### T5 400/630

230 V

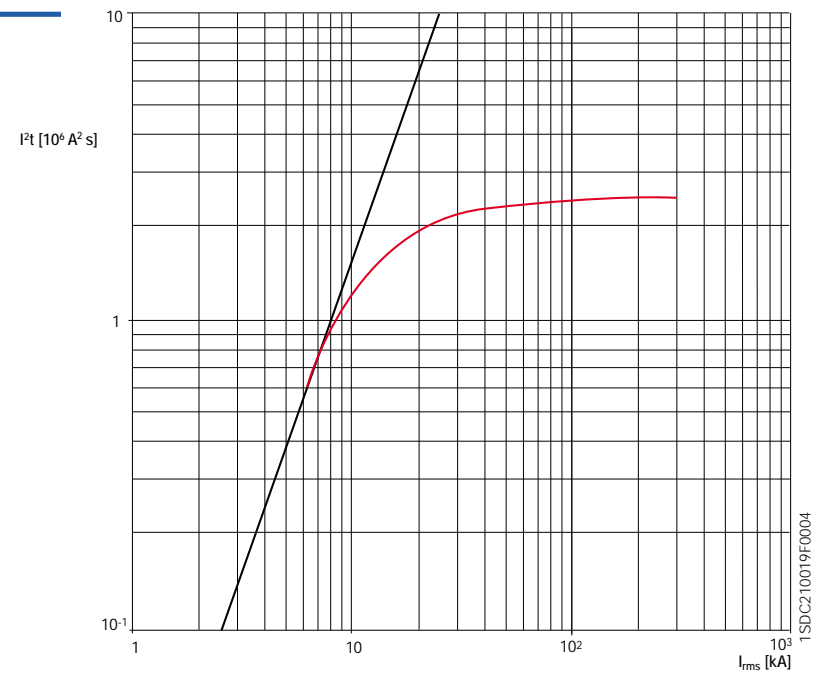

### 3 General characteristics

Specific let-through energy curves

**T6 630/800/1000**

230 V

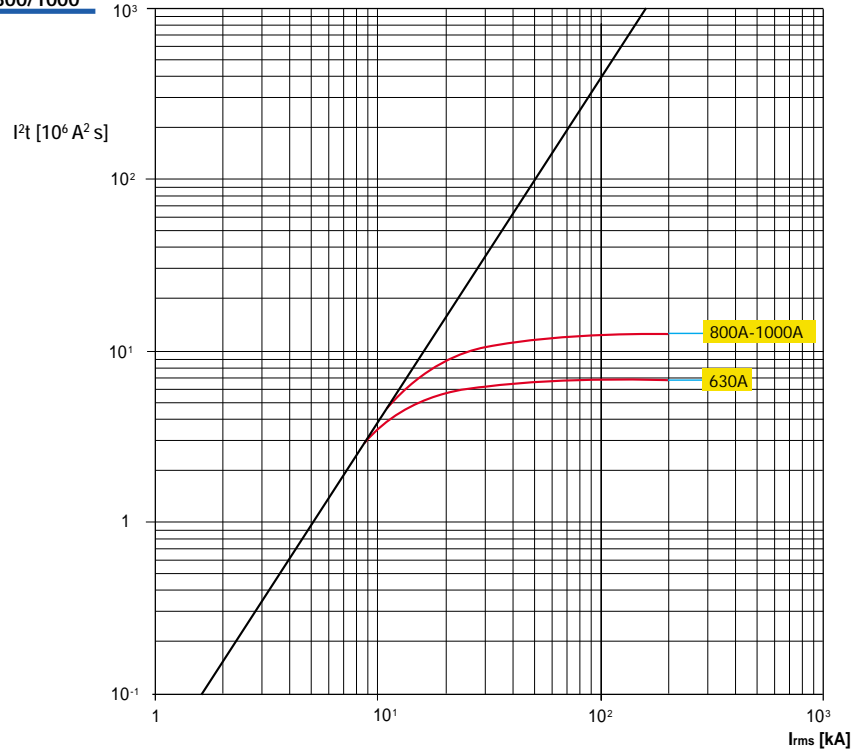

### 3 General characteristics

Specific let-through energy curves

**T7 800/1000/1250/1600**

230 V

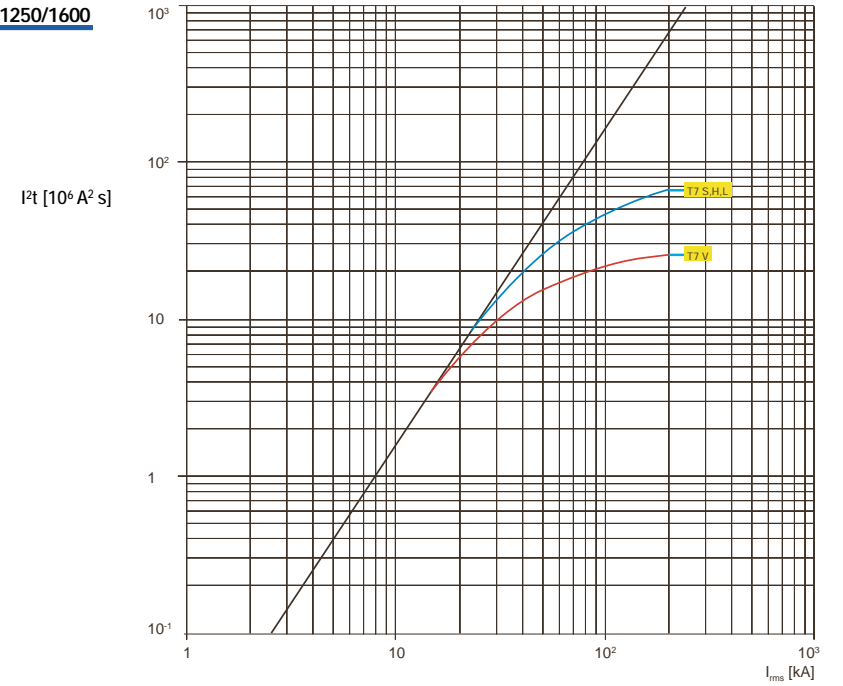

### 3 General characteristics

Specific let-through energy curves

#### T1 160

400-440 V

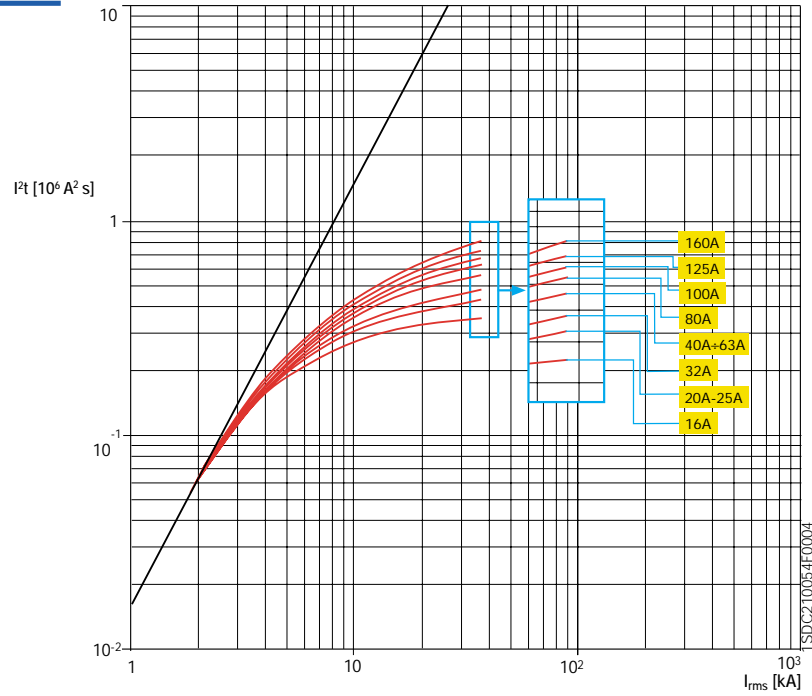

### 3 General characteristics

Specific let-through energy curves

#### T2 160

400-440 V

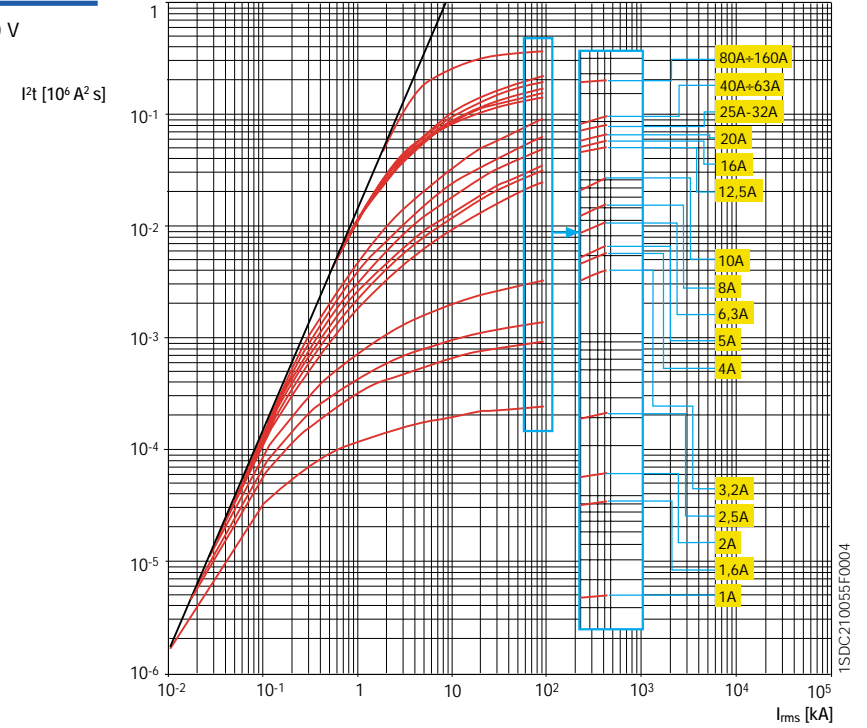

### 3 General characteristics

Specific let-through energy curves

#### T3 250

400-440 V

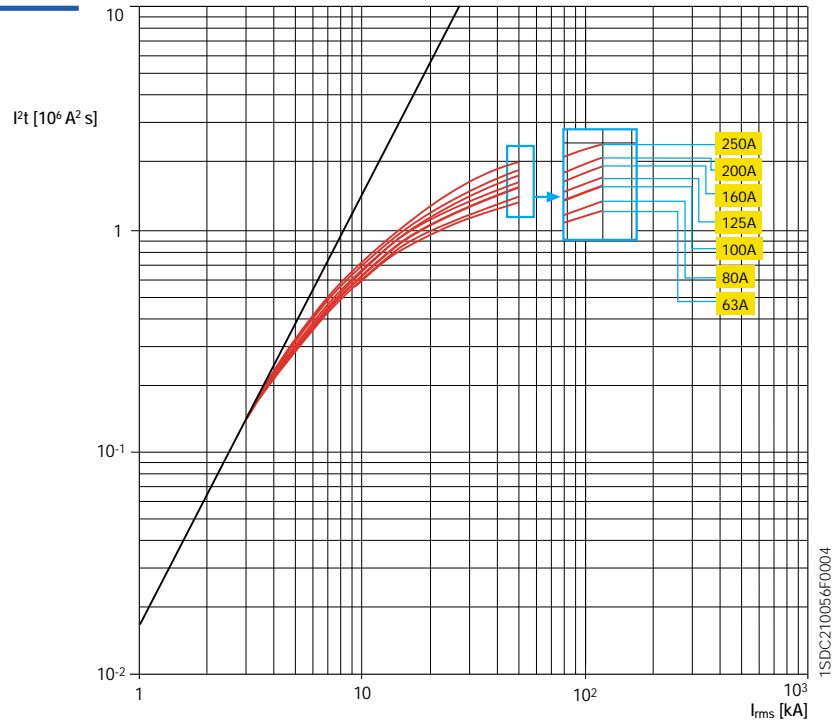

### 3 General characteristics

Specific let-through energy curves

#### T4 250/320

400-440 V

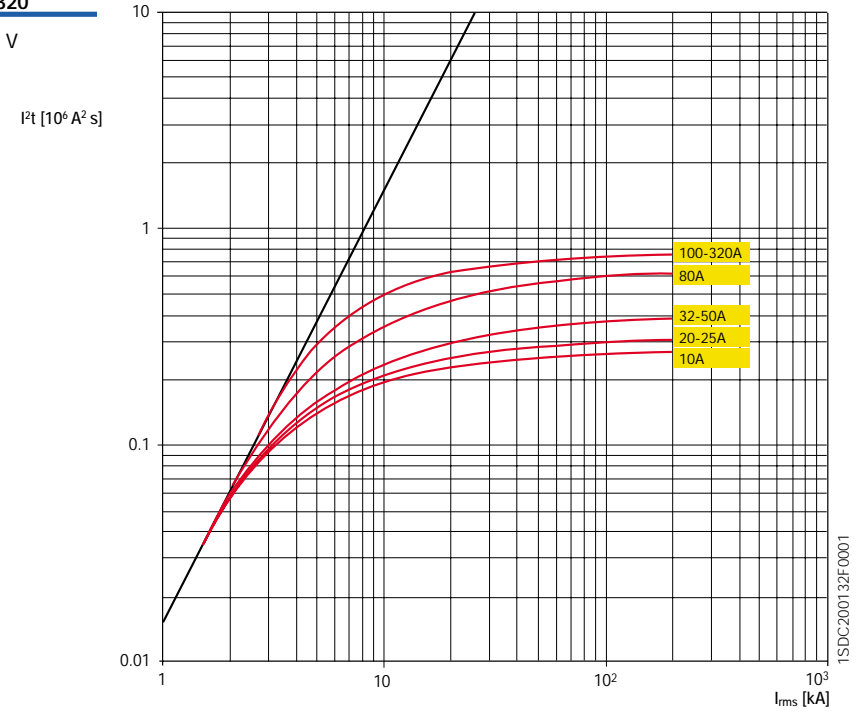

### 3 General characteristics

Specific let-through energy curves

#### T5 400/630

400-440 V

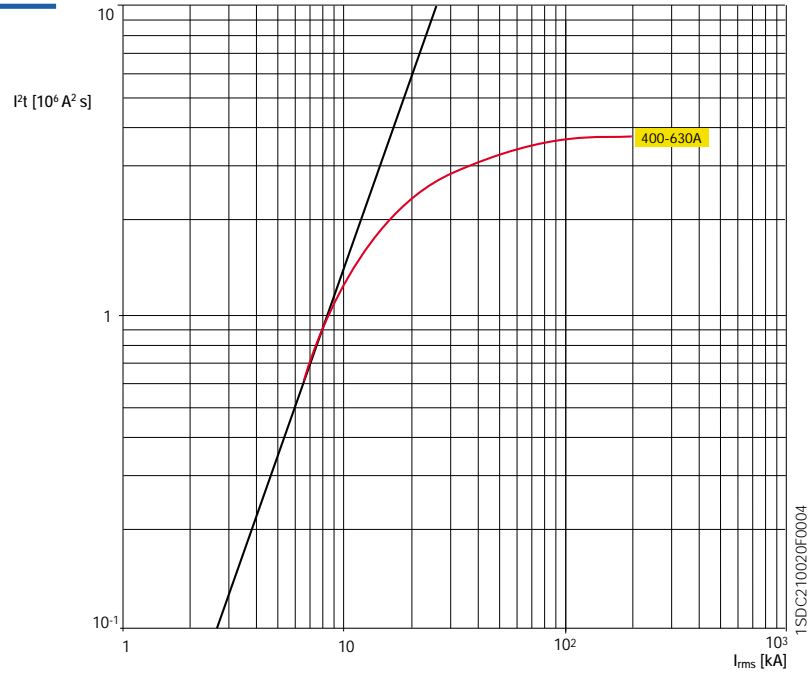

### 3 General characteristics

Specific let-through energy curves

#### T6 630/800/1000

400-440 V

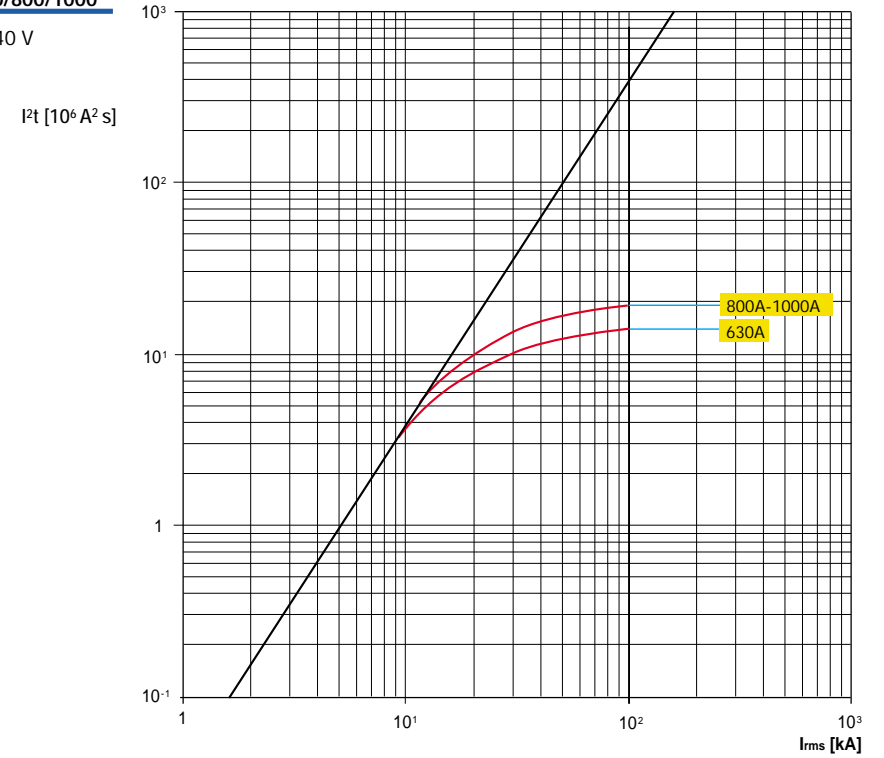

### 3 General characteristics

Specific let-through energy curves

**T7**  
800/1000/1250/1600

400-440 V

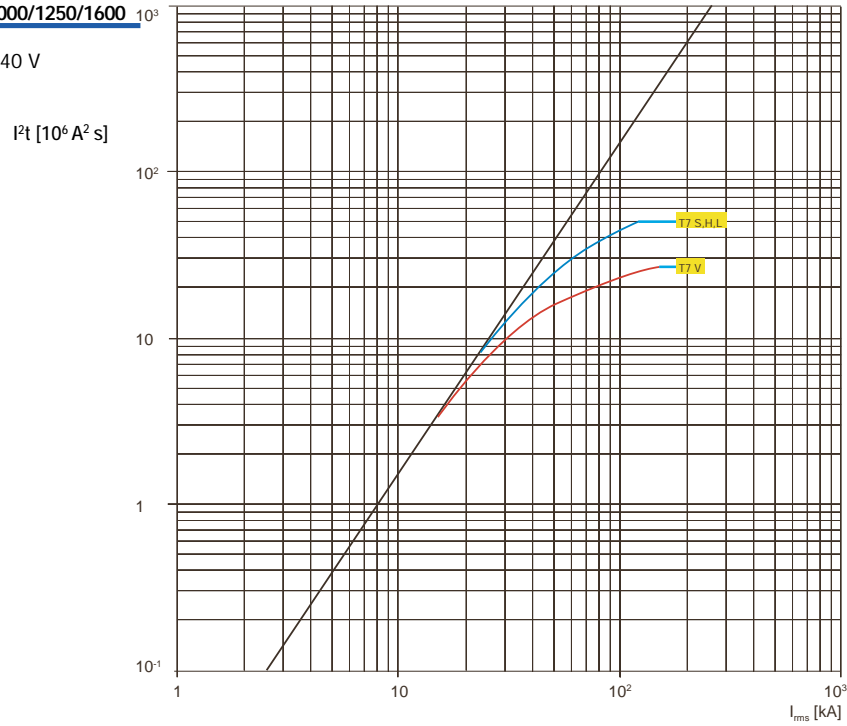

### 3 General characteristics

Specific let-through energy curves

**T1 160**

500 V

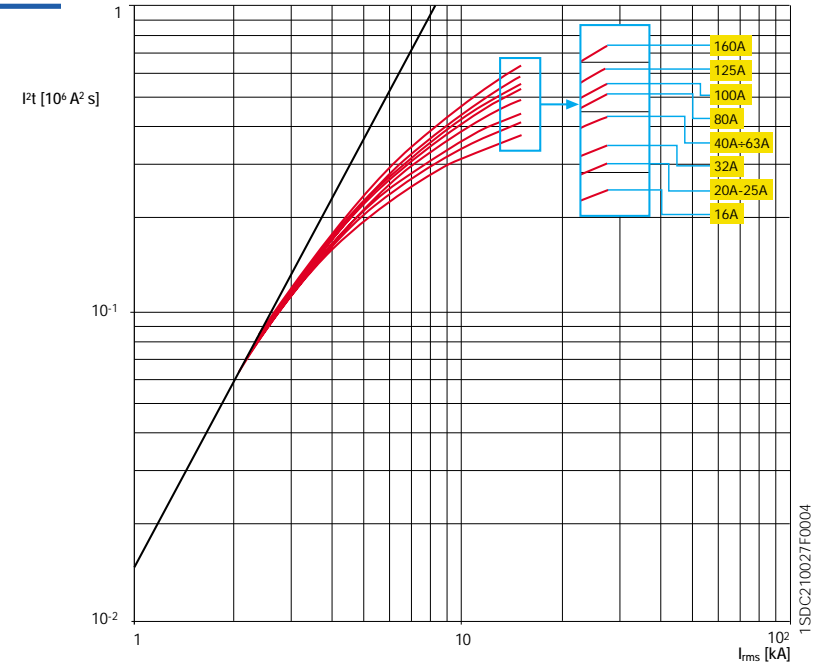

1SDC210027F0004

### 3 General characteristics

Specific let-through energy curves

#### T2 160

500 V

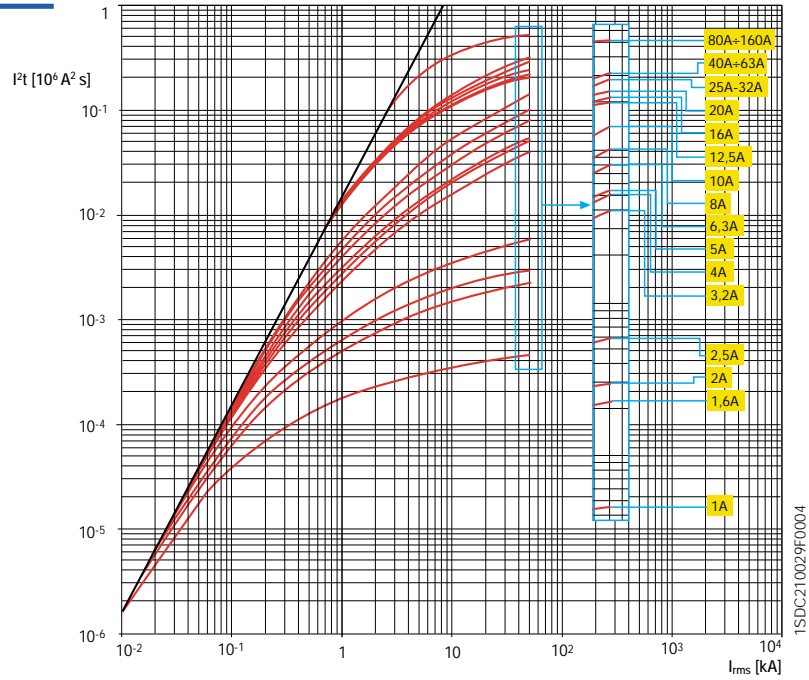

### 3 General characteristics

Specific let-through energy curves

#### T3 250

500 V

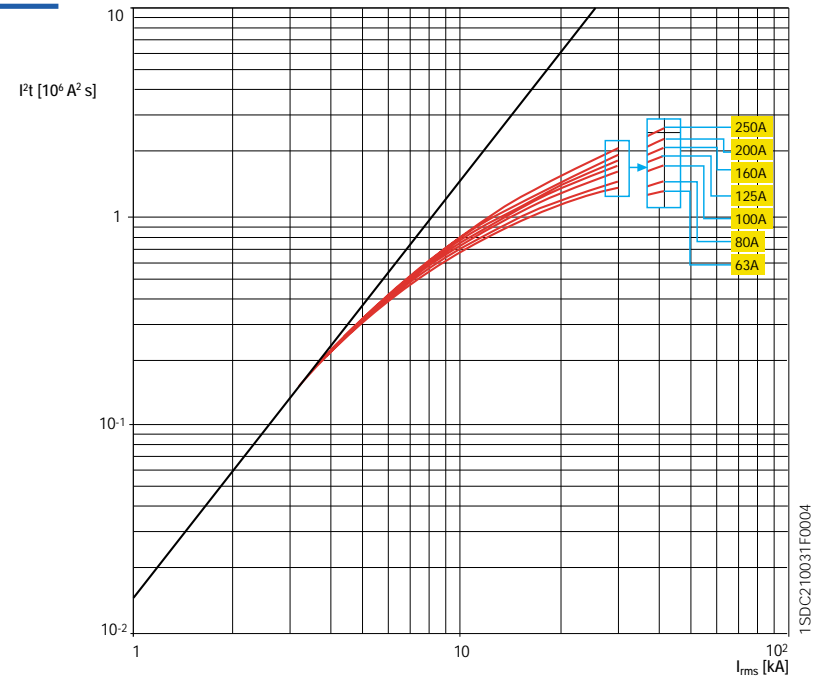

### 3 General characteristics

Specific let-through energy curves

#### T4 250/320

500 V

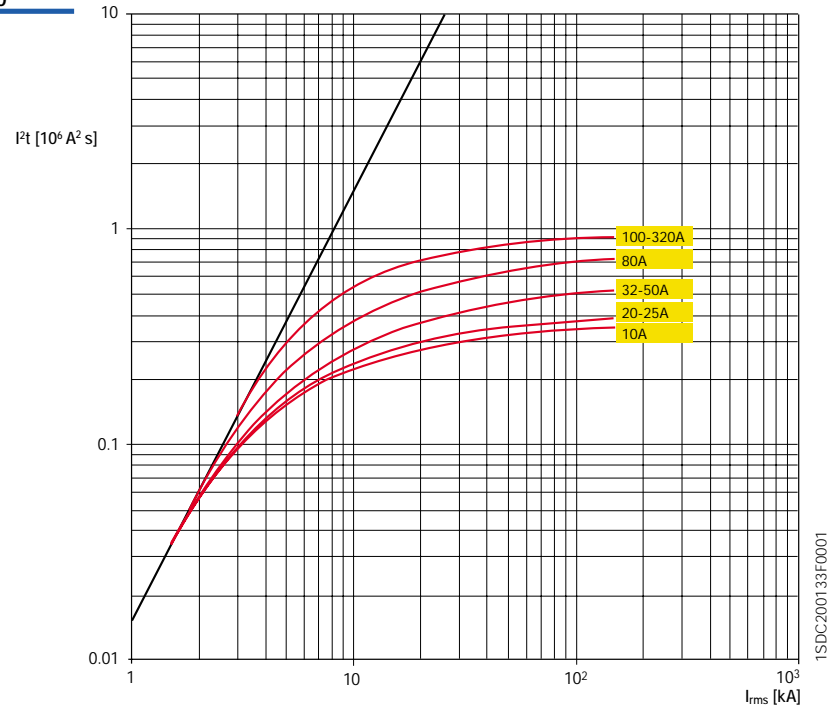

### 3 General characteristics

Specific let-through energy curves

#### T5 400/630

500 V

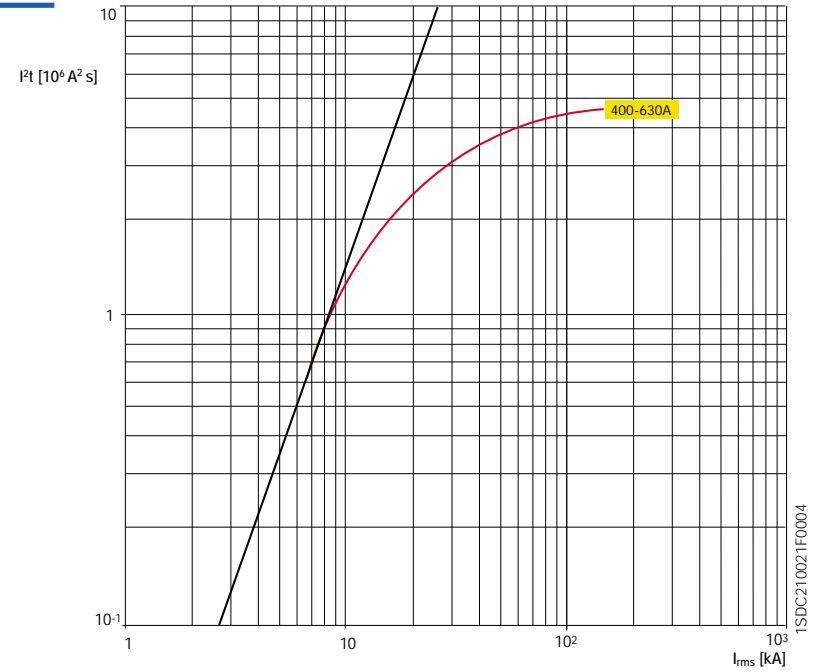



### 3 General characteristics

Specific let-through energy curves

#### T6 630/800/1000

500 V

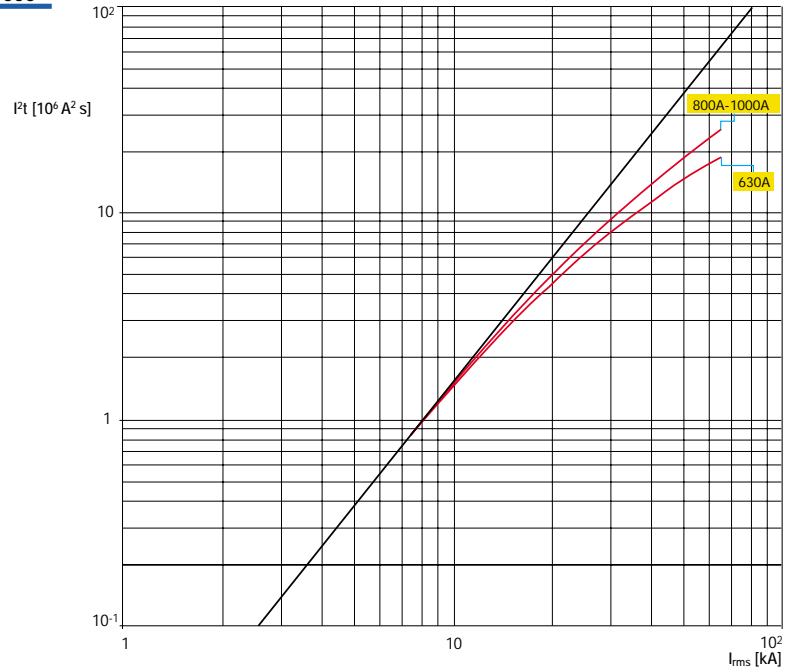

### 3 General characteristics

Specific let-through energy curves

#### T7 800/1000/1250/1600

500 V

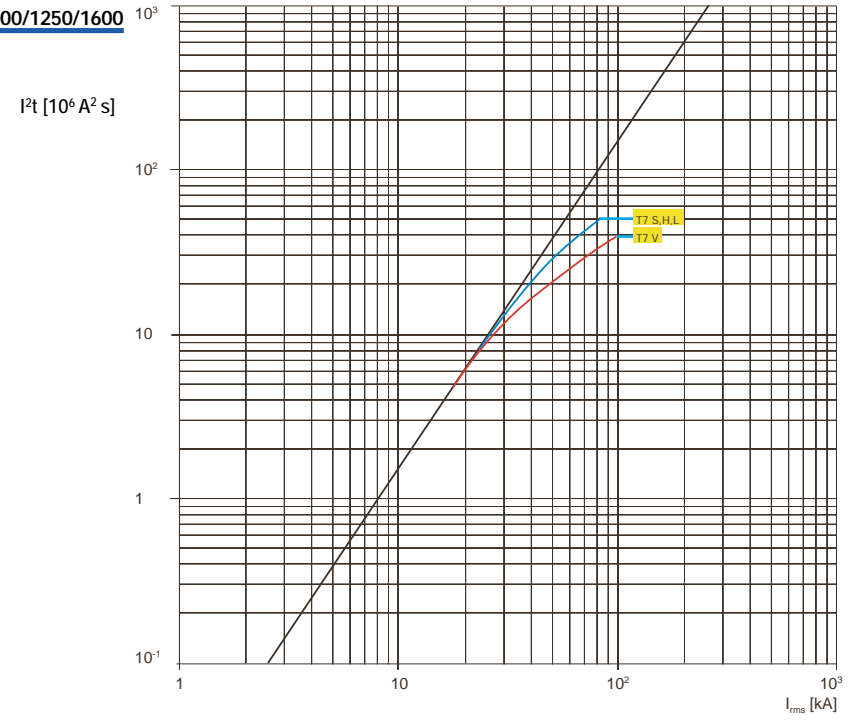

### 3 General characteristics

Specific let-through energy curves

#### T1 160

690 V

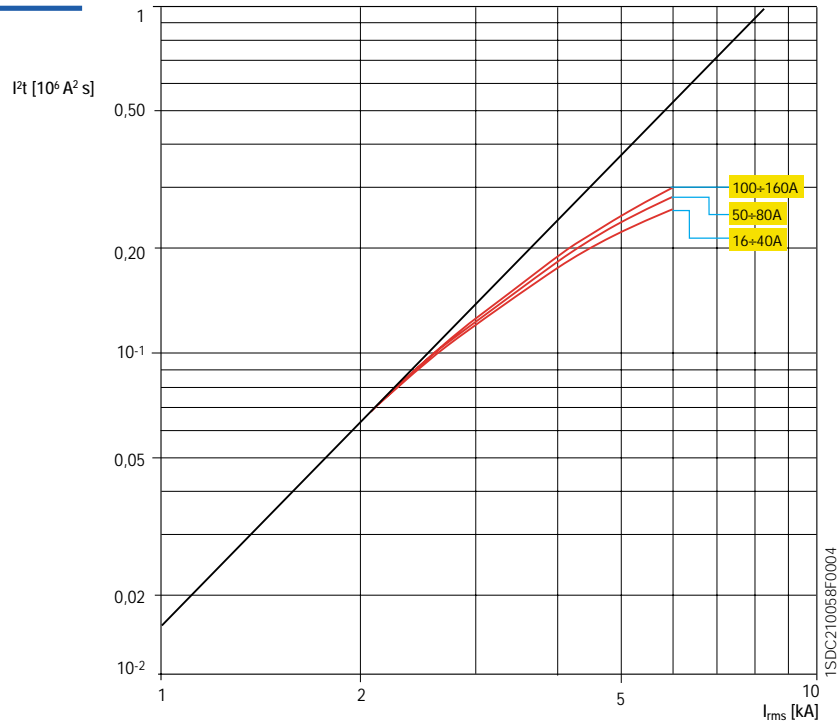

### 3 General characteristics

Specific let-through energy curves

#### T2 160

690 V

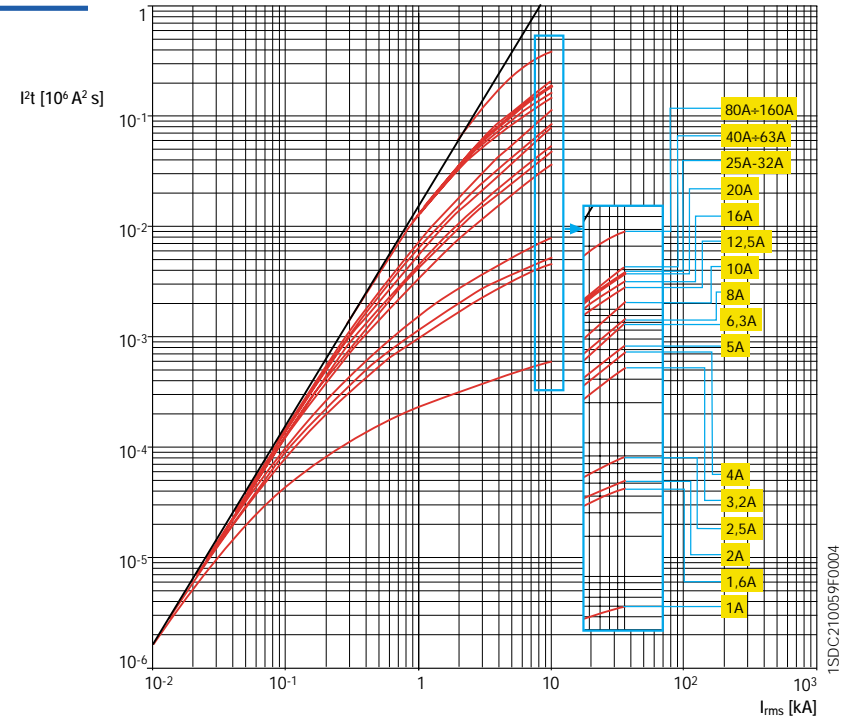

### 3 General characteristics

Specific let-through energy curves

#### T3 250

690 V

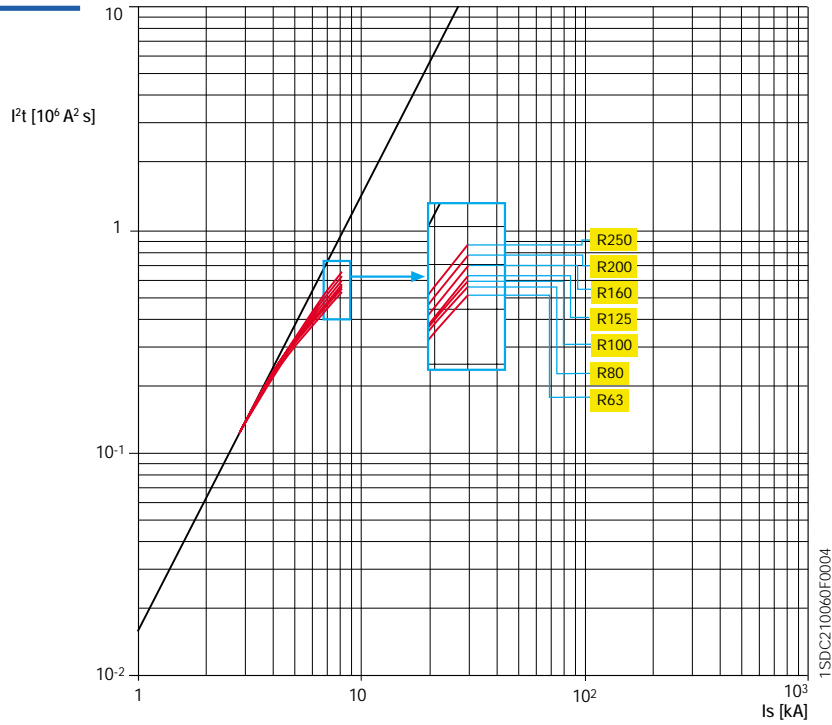

### 3 General characteristics

Specific let-through energy curves

#### T4 250/320

690 V

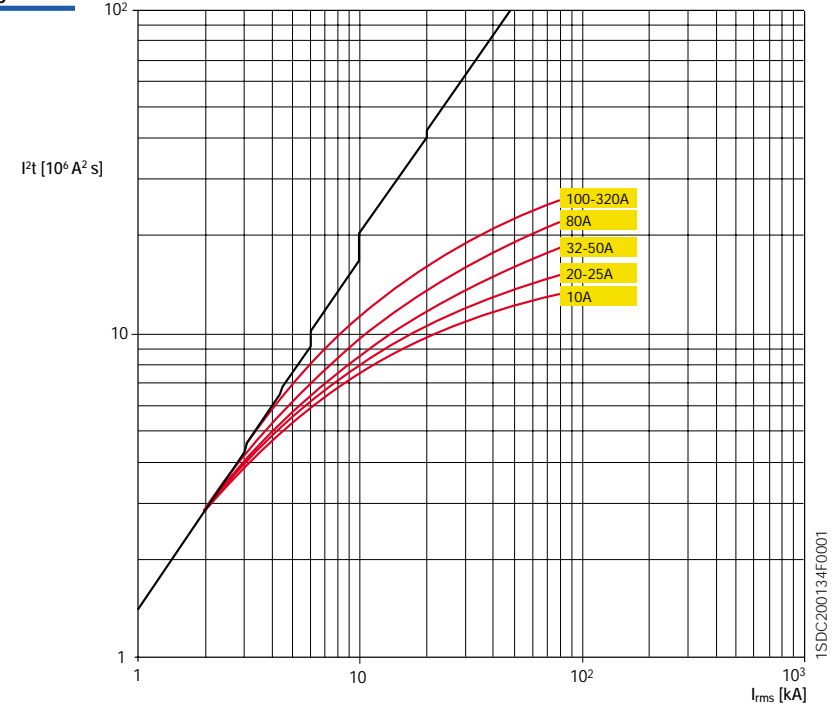

### 3 General characteristics

Specific let-through energy curves

#### T5 400/630

690 V

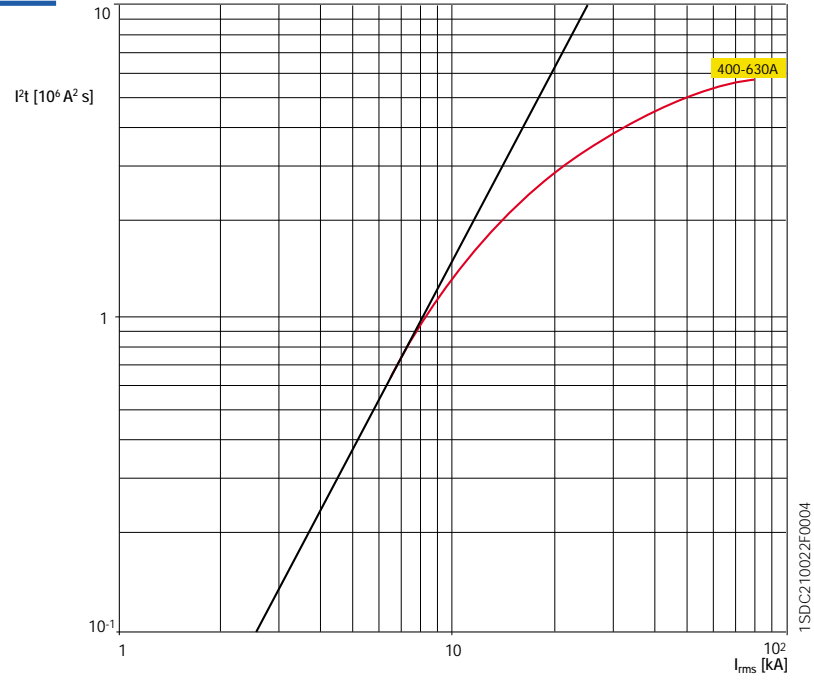

### 3 General characteristics

Specific let-through energy curves

#### T6 630/800/1000

690 V

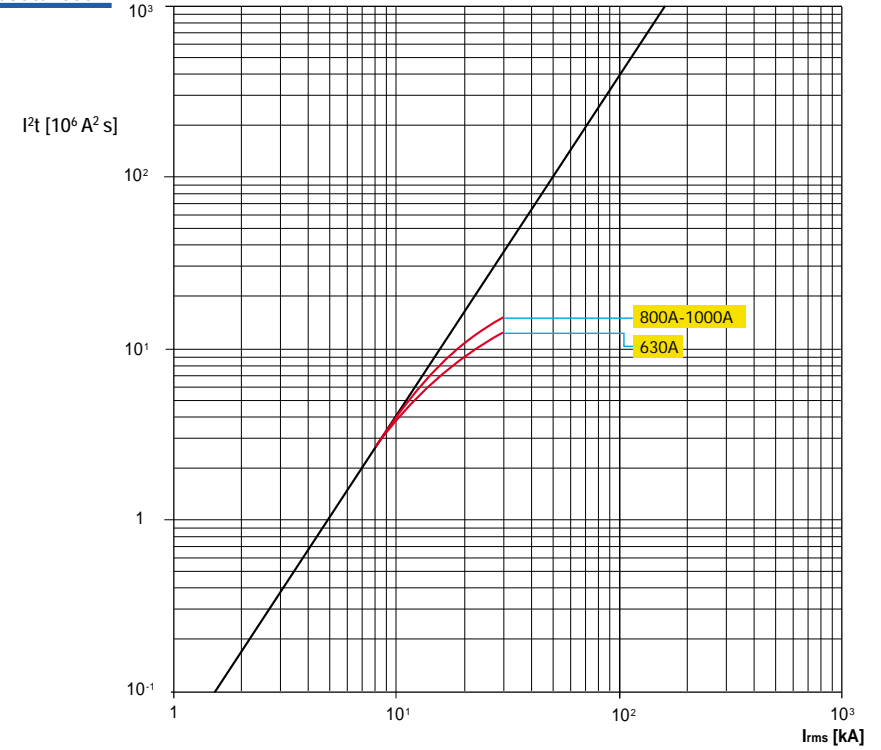

### 3 General characteristics

Specific let-through energy curves

**T7**  
**800/1000/1250/1600**

690 V

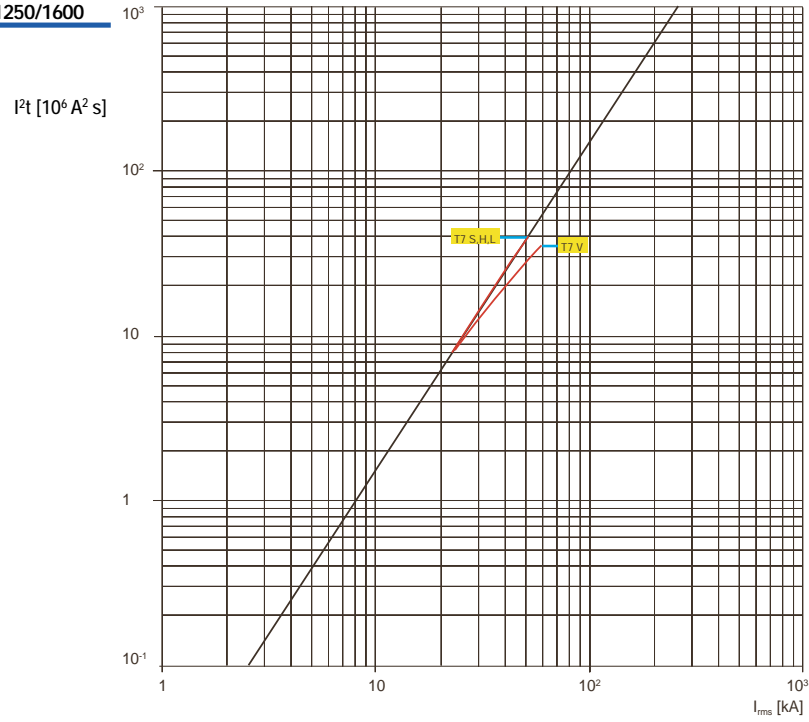

### 3 General characteristics

Specific let-through energy curves

**T4 250**  
**T5 400/630**

1000 V

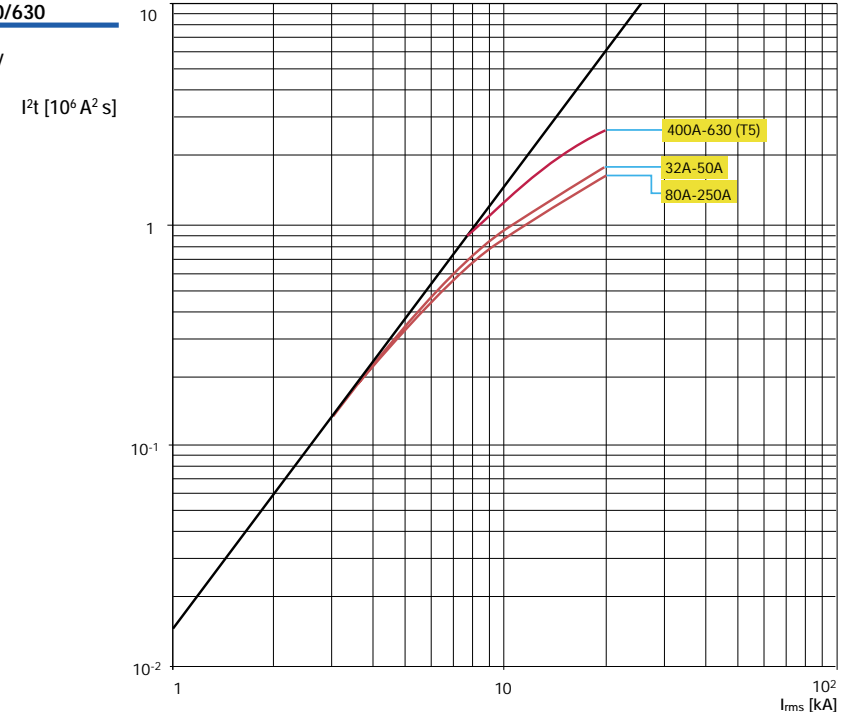

### 3 General characteristics

Specific let-through energy curves

**S7**

230 V

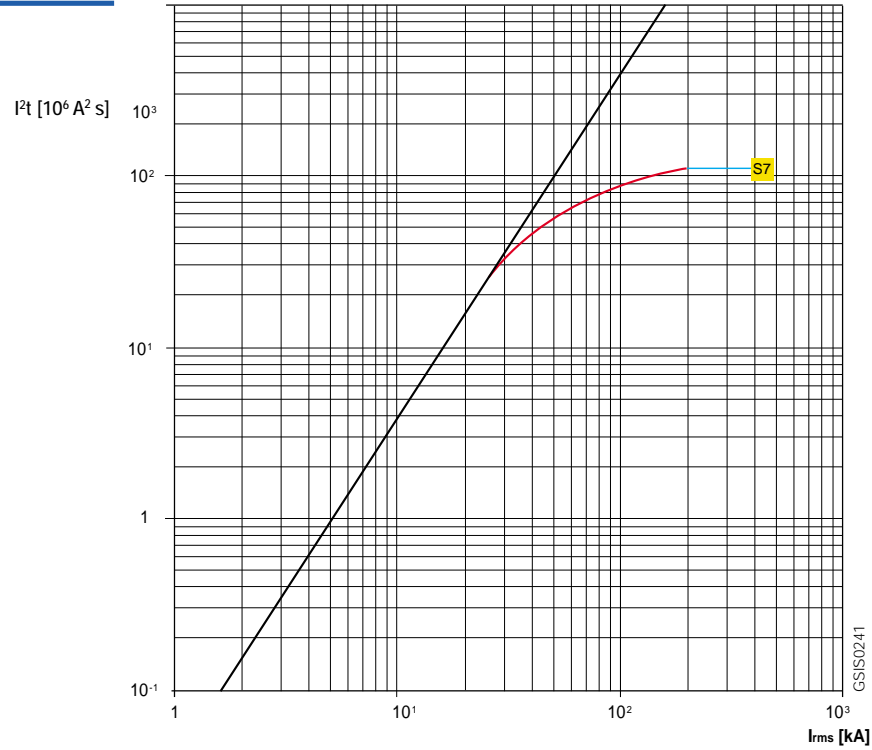

### 3 General characteristics

Specific let-through energy curves

**S7**

400-440 V

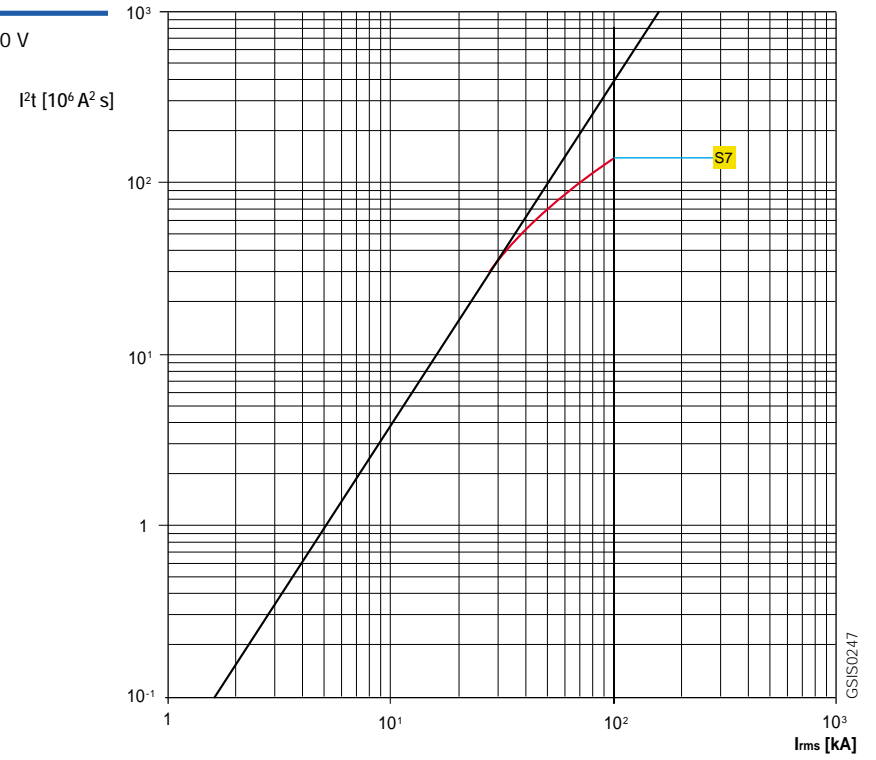

### 3 General characteristics

Specific let-through energy curves

**S7**

690 V

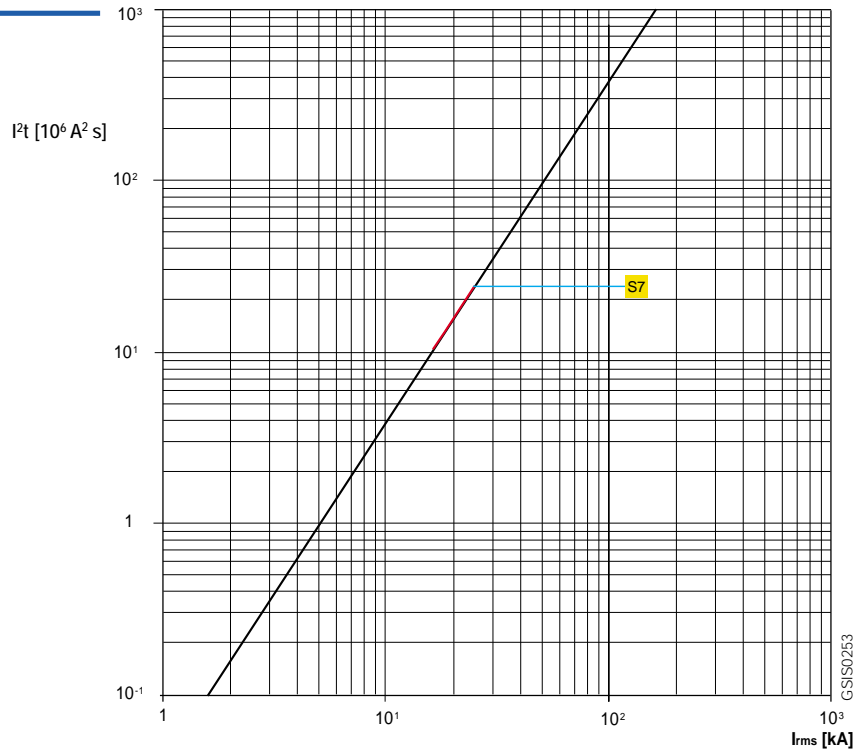

### 3 General characteristics

Specific let-through energy curves

**X1L**

690 V~  
380/415 V~

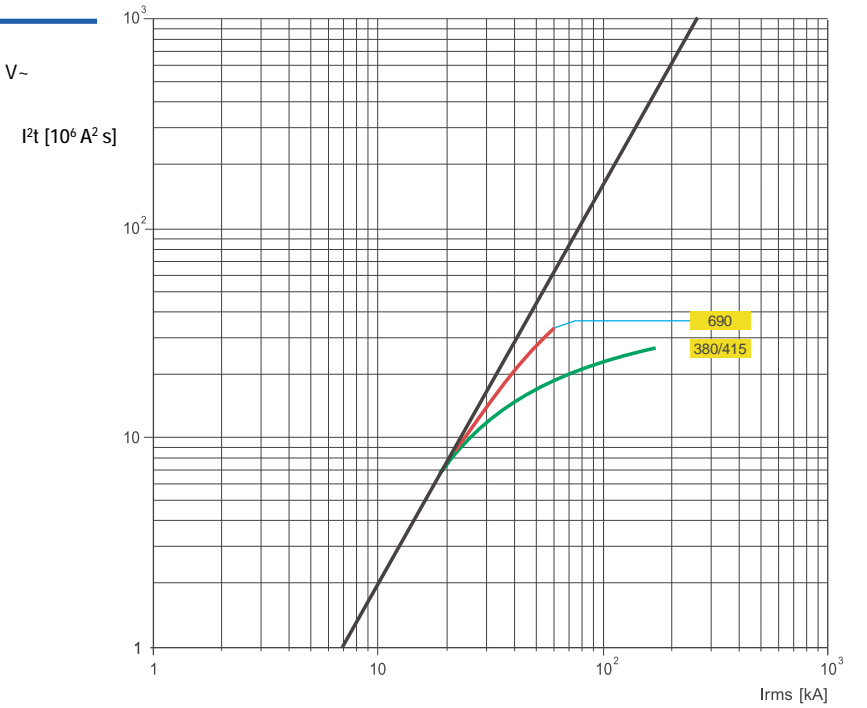

### 3 General characteristics

Specific let-through energy curves

#### E2L

690 V~  
380/415 V~

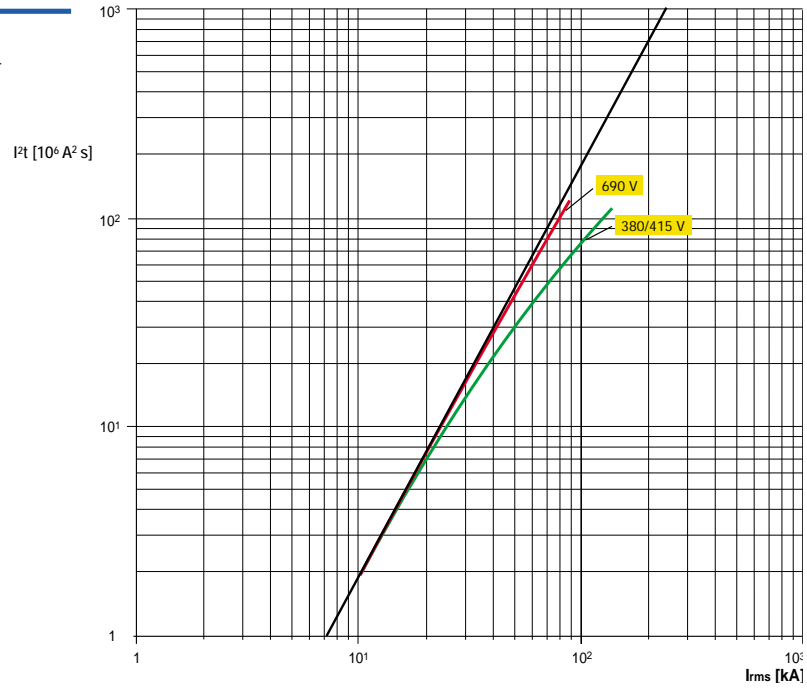

### 3 General characteristics

Specific let-through energy curves

#### E3L

690 V~  
380/415 V~

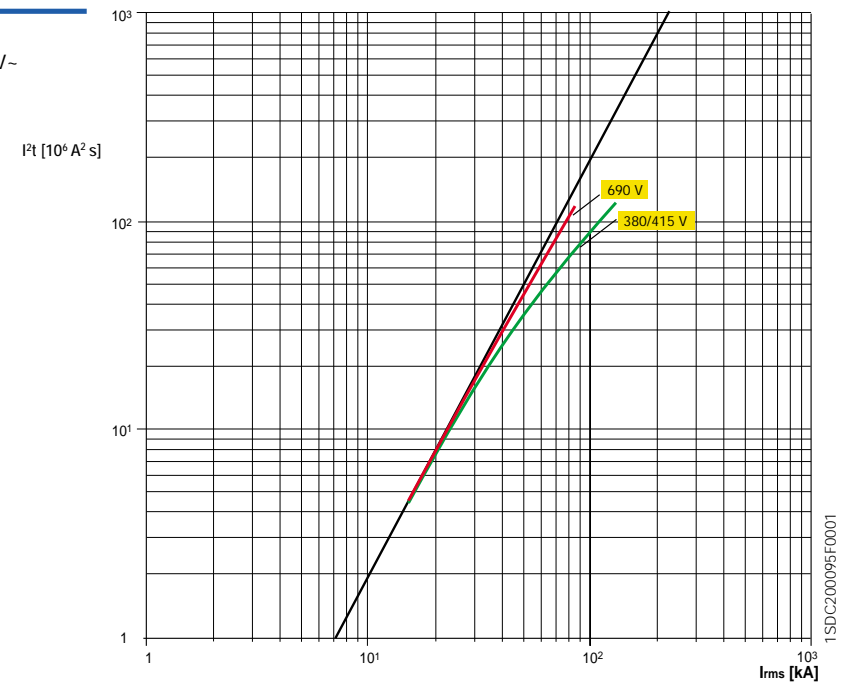



### 3 General characteristics

#### 3.5 Temperature derating

Standard IEC 60947-2 states that the temperature rise limits for circuit-breakers working at rated current must be within the limits given in the following table:

**Table 1 - Temperature rise limits for terminals and accessible parts**

Description of part*	Temperature rise limits K
- Terminal for external connections	80
- Manual operating means:	
metallic	25
non metallic	35
- Parts intended to be touched but not hand-held:	
metallic	40
non metallic	50
- Parts which need not be touched for normal operation:	
metallic	50
non metallic	60

\* No value is specified for parts other than those listed but no damage should be caused to adjacent parts of insulating materials.

These values are valid for a maximum reference ambient temperature of 40°C, as stated in Standard IEC 60947-1, clause 6.1.1.

Whenever the ambient temperature is other than 40°C, the value of the current which can be carried continuously by the circuit-breaker is given in the following tables:

#### Circuit-breakers with thermomagnetic release

##### Tmax T1 and T1 1P (\*)

In [A]	10 °C		20 °C		30 °C		40 °C		50 °C		60 °C		70 °C	
	MIN	MAX	MIN	MAX	MIN	MAX	MIN	MAX	MIN	MAX	MIN	MAX	MIN	MAX
16	13	18	12	18	11	17	11	16	11	15	10	14	9	13
20	16	23	15	22	15	21	14	20	13	19	12	18	11	16
25	20	29	19	28	18	26	18	25	16	23	15	22	14	20
32	26	37	25	35	24	34	22	32	21	30	20	28	18	26
40	32	46	31	44	29	42	28	40	26	38	25	35	23	33
50	40	58	39	55	37	53	35	50	33	47	31	44	28	41
63	51	72	49	69	46	66	44	63	41	59	39	55	36	51
80	64	92	62	88	59	84	56	80	53	75	49	70	46	65
100	81	115	77	110	74	105	70	100	66	94	61	88	57	81
125	101	144	96	138	92	131	88	125	82	117	77	109	71	102
160	129	184	123	176	118	168	112	160	105	150	98	140	91	130

(\*) For the T1 1P circuit-breaker (fitted with TMF fixed thermomagnetic release), consider only the column corresponding to the maximum adjustment of the TMD releases.

### 3 General characteristics

#### Tmax T2

In [A]	10 °C		20 °C		30 °C		40 °C		50 °C		60 °C		70 °C	
	MIN	MAX	MIN	MAX	MIN	MAX	MIN	MAX	MIN	MAX	MIN	MAX	MIN	MAX
1	0.8	1.1	0.8	1.1	0.7	1.1	0.7	1.0	0.7	0.9	0.6	0.9	0.6	0.8
1.6	1.3	1.8	1.2	1.8	1.2	1.7	1.1	1.6	1.0	1.5	1.0	1.4	0.9	1.3
2	1.6	2.3	1.5	2.2	1.5	2.1	1.4	2.0	1.3	1.9	1.2	1.7	1.1	1.6
2.5	2.0	2.9	1.9	2.8	1.8	2.6	1.8	2.5	1.6	2.3	1.5	2.2	1.4	2.0
3.2	2.6	3.7	2.5	3.5	2.4	3.4	2.2	3.2	2.1	3.0	1.9	2.8	1.8	2.6
4	3.2	4.6	3.1	4.4	2.9	4.2	2.8	4.0	2.6	3.7	2.4	3.5	2.3	3.2
5	4.0	5.7	3.9	5.5	3.7	5.3	3.5	5.0	3.3	4.7	3.0	4.3	2.8	4.0
6.3	5.1	7.2	4.9	6.9	4.6	6.6	4.4	6.3	4.1	5.9	3.8	5.5	3.6	5.1
8	6.4	9.2	6.2	8.8	5.9	8.4	5.6	8.0	5.2	7.5	4.9	7.0	4.5	6.5
10	8.0	11.5	7.7	11.0	7.4	10.5	7.0	10.0	6.5	9.3	6.1	8.7	5.6	8.1
12.5	10.1	14.4	9.6	13.8	9.2	13.2	8.8	12.5	8.2	11.7	7.6	10.9	7.1	10.1
16	13	18	12	18	12	17	11	16	10	15	10	14	9	13
20	16	23	15	22	15	21	14	20	13	19	12	17	11	16
25	20	29	19	28	18	26	18	25	16	23	15	22	14	20
32	26	37	25	35	24	34	22	32	21	30	19	28	18	26
40	32	46	31	44	29	42	28	40	26	37	24	35	23	32
50	40	57	39	55	37	53	35	50	33	47	30	43	28	40
63	51	72	49	69	46	66	44	63	41	59	38	55	36	51
80	64	92	62	88	59	84	56	80	52	75	49	70	45	65
100	80	115	77	110	74	105	70	100	65	93	61	87	56	81
125	101	144	96	138	92	132	88	125	82	117	76	109	71	101
160	129	184	123	178	118	168	112	160	105	150	97	139	90	129

#### Tmax T3

In [A]	10 °C		20 °C		30 °C		40 °C		50 °C		60 °C		70 °C	
	MIN	MAX	MIN	MAX	MIN	MAX	MIN	MAX	MIN	MAX	MIN	MAX	MIN	MAX
63	51	72	49	69	46	66	44	63	41	59	38	55	35	51
80	64	92	62	88	59	84	56	80	52	75	48	69	45	64
100	80	115	77	110	74	105	70	100	65	93	61	87	56	80
125	101	144	96	138	92	132	88	125	82	116	76	108	70	100
160	129	184	123	176	118	168	112	160	104	149	97	139	90	129
200	161	230	154	220	147	211	140	200	130	186	121	173	112	161
250	201	287	193	278	184	263	175	250	163	233	152	216	141	201

### 3 General characteristics

#### Tmax T4

In [A]	10 °C		20 °C		30 °C		40 °C		50 °C		60 °C		70 °C	
	MIN	MAX	MIN	MAX	MIN	MAX	MIN	MAX	MIN	MAX	MIN	MAX	MIN	MAX
20	19	27	18	24	16	23	14	20	12	17	10	15	8	13
32	26	43	24	39	22	36	19	32	16	27	14	24	11	21
50	37	62	35	58	33	54	30	50	27	46	25	42	22	39
80	59	98	55	92	52	86	48	80	44	74	40	66	32	58
100	83	118	80	113	74	106	70	100	66	95	59	85	49	75
125	103	145	100	140	94	134	88	125	80	115	73	105	63	95
160	130	185	124	176	118	168	112	160	106	150	100	104	90	130
200	162	230	155	220	147	210	140	200	133	190	122	175	107	160
250	200	285	193	275	183	262	175	250	168	240	160	230	150	220

#### Tmax T5

In [A]	10 °C		20 °C		30 °C		40 °C		50 °C		60 °C		70 °C	
	MIN	MAX	MIN	MAX	MIN	MAX	MIN	MAX	MIN	MAX	MIN	MAX	MIN	MAX
320	260	368	245	350	234	335	224	320	212	305	200	285	182	263
400	325	465	310	442	295	420	280	400	265	380	250	355	230	325
500	435	620	405	580	380	540	350	500	315	450	280	400	240	345

#### Tmax T6

In [A]	10 °C		20 °C		30 °C		40 °C		50 °C		60 °C		70 °C	
	MIN	MAX	MIN	MAX	MIN	MAX	MIN	MAX	MIN	MAX	MIN	MAX	MIN	MAX
630	520	740	493	705	462	660	441	630	405	580	380	540	350	500
800	685	965	640	905	605	855	560	800	520	740	470	670	420	610

### 3 General characteristics

#### Circuit-breakers with electronic release

#### Tmax T2 160

Fixed	up to 40 °C		50 °C		60 °C		70 °C	
	I <sub>max</sub> [A]	I <sub>t</sub>	I <sub>max</sub> [A]	I <sub>t</sub>	I <sub>max</sub> [A]	I <sub>t</sub>	I <sub>max</sub> [A]	I <sub>t</sub>
F	160	1	154	0.96	141	0.88	128	0.8
EF	160	1	154	0.96	141	0.88	128	0.8
ES	160	1	154	0.96	141	0.88	128	0.8
FC Cu	160	1	154	0.96	141	0.88	128	0.8
FC Cu	160	1	154	0.96	141	0.88	128	0.8
R	160	1	154	0.96	141	0.88	128	0.8

F = Front flat terminals; EF = Front extended terminals; ES = Front extended spread terminals;  
FC Cu = Front terminals for copper cables; FC CuAl = Front terminals for CuAl cables; R = Rear terminals

#### Tmax T2 160

Plug-in	up to 40 °C		50 °C		60 °C		70 °C	
	I <sub>max</sub> [A]	I <sub>t</sub>	I <sub>max</sub> [A]	I <sub>t</sub>	I <sub>max</sub> [A]	I <sub>t</sub>	I <sub>max</sub> [A]	I <sub>t</sub>
F	144	0.9	138	0.84	126	0.8	112	0.68
EF	144	0.9	138	0.84	126	0.8	112	0.68
ES	144	0.9	138	0.84	126	0.8	112	0.68
FC Cu	144	0.9	138	0.84	126	0.8	112	0.68
FC Cu	144	0.9	138	0.84	126	0.8	112	0.68
R	144	0.9	138	0.84	126	0.8	112	0.68

F = Front flat terminals; EF = Front extended terminals; ES = Front extended spread terminals;  
FC Cu = Front terminals for copper cables; FC CuAl = Front terminals for CuAl cables; R = Rear terminals

#### Tmax T4 250

Fixed	up to 40 °C		50 °C		60 °C		70 °C	
	I <sub>max</sub> [A]	I <sub>t</sub>	I <sub>max</sub> [A]	I <sub>t</sub>	I <sub>max</sub> [A]	I <sub>t</sub>	I <sub>max</sub> [A]	I <sub>t</sub>
FC	250	1	250	1	250	1	230	0.92
F	250	1	250	1	250	1	230	0.92
HR	250	1	250	1	250	1	220	0.88
VR	250	1	250	1	250	1	220	0.88

#### Plug-in - Withdrawable

FC	250	1	250	1	240	0.96	220	0.88
F	250	1	250	1	240	0.96	220	0.88
HR	250	1	250	1	230	0.92	210	0.84
VR	250	1	250	1	230	0.92	210	0.84

FC = Front terminals for cables; F = Front flat terminals; HR = Rear flat horizontal terminals; VR = Rear flat vertical terminals.

#### Tmax T4 320

Fixed	up to 40 °C		50 °C		60 °C		70 °C	
	I <sub>max</sub> [A]	I <sub>t</sub>	I <sub>max</sub> [A]	I <sub>t</sub>	I <sub>max</sub> [A]	I <sub>t</sub>	I <sub>max</sub> [A]	I <sub>t</sub>
FC	320	1	307	0.96	281	0.88	256	0.80
F	320	1	307	0.96	281	0.88	256	0.80
HR	320	1	294	0.92	269	0.84	243	0.76
VR	320	1	294	0.92	269	0.84	243	0.76

#### Plug-in - Withdrawable

FC	320	1	294	0.92	268	0.84	242	0.76
F	320	1	307	0.96	282	0.88	256	0.80
HR	320	1	294	0.92	268	0.84	242	0.76
VR	320	1	294	0.92	268	0.84	242	0.76

FC = Front terminals for cables; F = Front flat terminals; HR = Rear flat horizontal terminals; VR = Rear flat vertical terminals.

### 3 General characteristics

#### Tmax T5 400

Fixed	up to 40 °C		50 °C		60 °C		70 °C	
	I <sub>max</sub> [A]	I <sub>1</sub>	I <sub>max</sub> [A]	I <sub>1</sub>	I <sub>max</sub> [A]	I <sub>1</sub>	I <sub>max</sub> [A]	I <sub>1</sub>
FC	400	1	400	1	400	1	368	0.92
F	400	1	400	1	400	1	368	0.92
HR	400	1	400	1	400	1	352	0.88
VR	400	1	400	1	400	1	352	0.88
<b>Plug-in - Withdrawable</b>								
FC	400	1	400	1	382	0.96	350	0.88
F	400	1	400	1	382	0.96	350	0.88
HR	400	1	400	1	368	0.92	336	0.84
VR	400	1	400	1	368	0.92	336	0.84

FC = Front terminals for cables; F = Front flat terminals; HR = Rear flat horizontal terminals; VR = Rear flat vertical terminals.

#### Tmax T5 630

Fixed	up to 40 °C		50 °C		60 °C		70 °C	
	I <sub>max</sub> [A]	I <sub>1</sub>	I <sub>max</sub> [A]	I <sub>1</sub>	I <sub>max</sub> [A]	I <sub>1</sub>	I <sub>max</sub> [A]	I <sub>1</sub>
FC	630	1	605	0.96	554	0.88	504	0.80
F	630	1	605	0.96	554	0.88	504	0.80
HR	630	1	580	0.92	529	0.84	479	0.76
VR	630	1	580	0.92	529	0.84	479	0.76
<b>Plug-in - Withdrawable</b>								
F	630	1	607	0.96	552	0.88	476	0.76
HR	630	1	580	0.92	517	0.82	454	0.72
VR	630	1	580	0.92	517	0.82	454	0.72

FC = Front terminals for cables; F = Front flat terminals; HR = Rear flat horizontal terminals; VR = Rear flat vertical terminals.

#### Tmax T6 630

Fixed	up to 40 °C		50 °C		60 °C		70 °C	
	I <sub>max</sub> [A]	I <sub>1</sub>	I <sub>max</sub> [A]	I <sub>1</sub>	I <sub>max</sub> [A]	I <sub>1</sub>	I <sub>max</sub> [A]	I <sub>1</sub>
F	630	1	630	1	630	1	598.5	0.95
FC	630	1	630	1	598.5	0.95	567	0.9
R (HR - VR)	630	1	630	1	567	0.9	504	0.8
<b>Withdrawable</b>								
EF	630	1	630	1	598.5	0.95	567	0.9
VR	630	1	630	1	598.5	0.95	567	0.9
HR	630	1	598.5	0.95	567	0.9	504	0.8

FC = Front terminals for cables; F = Front flat terminals; HR = Rear flat horizontal terminals; VR = Rear flat vertical terminals; R = Rear terminals; EF = Front extended.

### 3 General characteristics

#### Tmax T6 800

Fixed	up to 40 °C		50 °C		60 °C		70 °C	
	I <sub>max</sub> [A]	I <sub>1</sub>	I <sub>max</sub> [A]	I <sub>1</sub>	I <sub>max</sub> [A]	I <sub>1</sub>	I <sub>max</sub> [A]	I <sub>1</sub>
F	800	1	800	1	800	1	760	0.95
FC	800	1	800	1	760	0.95	720	0.9
R (HR - VR)	800	1	800	1	720	0.9	640	0.8
<b>Withdrawable</b>								
EF	800	1	800	1	760	0.95	720	0.9
VR	800	1	800	1	760	0.95	720	0.9
HR	800	1	760	0.95	720	0.9	640	0.8

FC = Front terminals for cables; F = Front flat terminals; HR = Rear flat horizontal terminals; VR = Rear flat vertical terminals; R = Rear terminals; EF = Front extended.

#### Tmax T6 1000

Fixed	up to 40 °C		50 °C		60 °C		70 °C	
	I <sub>max</sub> [A]	I <sub>1</sub>	I <sub>max</sub> [A]	I <sub>1</sub>	I <sub>max</sub> [A]	I <sub>1</sub>	I <sub>max</sub> [A]	I <sub>1</sub>
FC	1000	1	1000	1	913	0.91	817	0.82
R (HR)	1000	1	926	0.93	845	0.85	756	0.76
R (VR)	1000	1	961	0.96	877	0.88	784	0.78

FC=Front cables terminals; R=Rear terminals;HR=Rear flat horizontal terminals;VR=Rear flat terminals

#### Tmax T7 1000 (V version)

Fixed	up to 40 °C		50 °C		60 °C		70 °C	
	I <sub>max</sub> [A]	I <sub>1</sub>	I <sub>max</sub> [A]	I <sub>1</sub>	I <sub>max</sub> [A]	I <sub>1</sub>	I <sub>max</sub> [A]	I <sub>1</sub>
VR	1000	1	1000	1	1000	1	894	0.89
EF-HR	1000	1	1000	1	895	0.89	784	0.78

#### Withdrawable

VR	1000	1	1000	1	913	0.91	816	0.82
EF-HR	1000	1	1000	1	895	0.89	784	0.78

EF = extended front;HR=Rear flat horizontal;VR=Rear flat vertical

#### Tmax T7 1250 (V versions)

Fixed	up to 40 °C		50 °C		60 °C		70 °C	
	I <sub>max</sub> [A]	I <sub>1</sub>	I <sub>max</sub> [A]	I <sub>1</sub>	I <sub>max</sub> [A]	I <sub>1</sub>	I <sub>max</sub> [A]	I <sub>1</sub>
VR	1250	1	1201	0.96	1096	0.88	981	0.78
EF-HR	1250	1	1157	0.93	1056	0.85	945	0.76

#### Withdrawable

VR	1250	1	1157	0.93	1056	0.85	945	0.76
EF-HR	1250	1	1000	0.8	913	0.73	816	0.65

EF=extended front;HR=Rear flat horizontal;VR=Rear flat vertical

### 3 General characteristics

#### Tmax T7 1250 (S-H-L versions)

Fixed	up to 40 °C		50 °C		60 °C		70 °C	
	I <sub>max</sub> [A]	I <sub>1</sub>	I <sub>max</sub> [A]	I <sub>1</sub>	I <sub>max</sub> [A]	I <sub>1</sub>	I <sub>max</sub> [A]	I <sub>1</sub>
VR	1250	1	1250	1	1250	1	1118	0,89
EF-HR	1250	1	1250	1	1118	0,89	980	0,78

#### Withdrawable

VR	1250	1	1250	1	1141	0,91	1021	0,82
EF-HR	1250	1	1250	1	1118	0,89	980	0,78

EF=extended front;HR=Rear flat horizontal;VR=Rear flat vertical

#### Tmax T7 1600 (S-H-L versions)

Fixed	up to 40 °C		50 °C		60 °C		70 °C	
	I <sub>max</sub> [A]	I <sub>1</sub>	I <sub>max</sub> [A]	I <sub>1</sub>	I <sub>max</sub> [A]	I <sub>1</sub>	I <sub>max</sub> [A]	I <sub>1</sub>
VR	1600	1	1537	0,96	1403	0,88	1255	0,78
EF-HR	1600	1	1481	0,93	1352	0,85	1209	0,76

#### Withdrawable

VR	1600	1	1481	0,93	1352	0,85	1209	0,76
EF-HR	1600	1	1280	0,8	1168	0,73	1045	0,65

EF=extended front;HR=Rear flat horizontal;VR=Rear flat vertical

#### SACE Isomax S7 1600

Fixed	up to 40 °C		50 °C		60 °C		70 °C	
	I <sub>max</sub> [A]	I <sub>1</sub>	I <sub>max</sub> [A]	I <sub>1</sub>	I <sub>max</sub> [A]	I <sub>1</sub>	I <sub>max</sub> [A]	I <sub>1</sub>
Front flat bar	1600	1	1520	0,95	1440	0,9	1280	0,8
Rear vertical flat bar	1600	1	1520	0,95	1440	0,9	1280	0,8
Rear horizontal flat bar	1600	1	1440	0,9	1280	0,8	1120	0,7

#### Plug-in - Withdrawable

Front flat bar	1600	1	1440	0,9	1280	0,8	1120	0,7
Rear vertical flat bar	1600	1	1440	0,9	1280	0,8	1120	0,7
Rear horizontal flat bar	1600	1	1280	0,8	1120	0,7	906	0,6

### 3 General characteristics

#### Emax X1 with horizontal rear terminals

Temperature [°C]	X1 630		X1 800		X1 1000		X1 1250		X1 1600	
	%	[A]	%	[A]	%	[A]	%	[A]	%	[A]
10	100	630	100	800	100	1000	100	1250	100	1600
20	100	630	100	800	100	1000	100	1250	100	1600
30	100	630	100	800	100	1000	100	1250	100	1600
40	100	630	100	800	100	1000	100	1250	100	1600
45	100	630	100	800	100	1000	100	1250	100	1600
50	100	630	100	800	100	1000	100	1250	97	1550
55	100	630	100	800	100	1000	100	1250	94	1500
60	100	630	100	800	100	1000	100	1250	93	1480

#### Emax X1 with vertical rear terminals

Temperature [°C]	X1 630		X1 800		X1 1000		X1 1250		X1 1600	
	%	[A]	%	[A]	%	[A]	%	[A]	%	[A]
10	100	630	100	800	100	1000	100	1250	100	1600
20	100	630	100	800	100	1000	100	1250	100	1600
30	100	630	100	800	100	1000	100	1250	100	1600
40	100	630	100	800	100	1000	100	1250	100	1600
45	100	630	100	800	100	1000	100	1250	100	1600
50	100	630	100	800	100	1000	100	1250	100	1600
55	100	630	100	800	100	1000	100	1250	98	1570
60	100	630	100	800	100	1000	100	1250	95	1520

#### Emax E1

Temperature [°C]	E1 800		E1 1000		E1 1250		E1 1600	
	%	[A]	%	[A]	%	[A]	%	[A]
10	100	800	100	1000	100	1250	100	1600
20	100	800	100	1000	100	1250	100	1600
30	100	800	100	1000	100	1250	100	1600
40	100	800	100	1000	100	1250	100	1600
45	100	800	100	1000	100	1250	98	1570
50	100	800	100	1000	100	1250	96	1530
55	100	800	100	1000	100	1250	94	1500
60	100	800	100	1000	100	1250	92	1470
65	100	800	100	1000	99	1240	89	1430
70	100	800	100	1000	98	1230	87	1400

### 3 General characteristics

#### Emax E2

Temperature [°C]	E2 800		E2 1000		E2 1250		E2 1600		E2 2000	
	%	[A]	%	[A]	%	[A]	%	[A]	%	[A]
10	100	800	100	1000	100	1250	100	1600	100	2000
20	100	800	100	1000	100	1250	100	1600	100	2000
30	100	800	100	1000	100	1250	100	1600	100	2000
40	100	800	100	1000	100	1250	100	1600	100	2000
45	100	800	100	1000	100	1250	100	1600	100	2000
50	100	800	100	1000	100	1250	100	1600	97	1945
55	100	800	100	1000	100	1250	100	1600	94	1885
60	100	800	100	1000	100	1250	98	1570	91	1825
65	100	800	100	1000	100	1250	96	1538	88	1765
70	100	800	100	1000	100	1250	94	1510	85	1705

#### Emax E3

Temperature [°C]	E3 800		E3 1000		E3 1250		E3 1600		E3 2000		E3 2500		E3 3200	
	%	[A]	%	[A]	%	[A]	%	[A]	%	[A]	%	[A]	%	[A]
10	100	800	100	1000	100	1250	100	1600	100	2000	100	2500	100	3200
20	100	800	100	1000	100	1250	100	1600	100	2000	100	2500	100	3200
30	100	800	100	1000	100	1250	100	1600	100	2000	100	2500	100	3200
40	100	800	100	1000	100	1250	100	1600	100	2000	100	2500	100	3200
45	100	800	100	1000	100	1250	100	1600	100	2000	100	2500	100	3200
50	100	800	100	1000	100	1250	100	1600	100	2000	100	2500	97	3090
55	100	800	100	1000	100	1250	100	1600	100	2000	100	2500	93	2975
60	100	800	100	1000	100	1250	100	1600	100	2000	100	2500	89	2860
65	100	800	100	1000	100	1250	100	1600	100	2000	97	2425	86	2745
70	100	800	100	1000	100	1250	100	1600	100	2000	94	2350	82	2630

### 3 General characteristics

#### Emax E4

Temperature [°C]	E4 3200		E4 4000	
	%	[A]	%	[A]
10	100	3200	100	4000
20	100	3200	100	4000
30	100	3200	100	4000
40	100	3200	100	4000
45	100	3200	100	4000
50	100	3200	98	3900
55	100	3200	95	3790
60	100	3200	92	3680
65	98	3120	89	3570
70	95	3040	87	3460

#### Emax E6

Temperature [°C]	E6 3200		E6 4000		E6 5000		E6 6300	
	%	[A]	%	[A]	%	[A]	%	[A]
10	100	3200	100	4000	100	5000	100	6300
20	100	3200	100	4000	100	5000	100	6300
30	100	3200	100	4000	100	5000	100	6300
40	100	3200	100	4000	100	5000	100	6300
45	100	3200	100	4000	100	5000	100	6300
50	100	3200	100	4000	100	5000	100	6300
55	100	3200	100	4000	100	5000	98	6190
60	100	3200	100	4000	98	4910	96	6070
65	100	3200	100	4000	96	4815	94	5850
70	100	3200	100	4000	94	4720	92	5600

### 3 General characteristics

The following table lists examples of the continuous current carrying capacity for circuit-breakers installed in a switchboard with the dimensions indicated below. These values refer to withdrawable switchgear installed in non segregated switchboards with a protection rating up to IP31, and following dimensions: 2000x400x400 (HxLxD) for X1, 2300x800x900 (HxLxD) for X1 - E1 - E2 - E3; 2300x1400x1500 (HxLxD) for E4 - E6.

The values refer to a maximum temperature at the terminals of 120 °C. For withdrawable circuit-breakers with a rated current of 6300 A, the use of vertical rear terminals is recommended.

For switchboards with the following dimensions (mm): 2000x400x400

Type	Iu [A]	Vertical terminals			Horizontal and front terminals				
		Continuous capacity [A]			Continuous capacity [A]				
		35 °C	45 °C	55 °C	35 °C	45 °C	55 °C		
							Busbars section [mm <sup>2</sup> ]		
X1B/N/L 06	630	630	630	630	2x(40x5)	630	630	630	2x(40x5)
X1B/N/L 08	800	800	800	800	2x(50x5)	800	800	800	2x(50x5)
X1B/N/L 10	1000	1000	1000	1000	2x(50x8)	1000	1000	1000	2x(50x10)
X1L 10	1000	1000	1000	960	2x(50x8)	1000	950	890	2x(50x10)
X1B/N/L 12	1250	1250	1250	1250	2x(50x8)	1250	1250	1200	2x(50x10)
X1L 12	1250	1250	1205	1105	2x(50x8)	1250	1125	955	2x(50x10)
X1B/N 16	1600	1520	1440	1340	2x(50x10)	1400	1330	1250	3x(50x8)

For switchboards with the following dimensions (mm): 2300x800x900

Type	Iu [A]	Vertical terminals			Horizontal and front terminals				
		Continuous capacity [A]			Continuous capacity [A]				
		35 °C	45 °C	55 °C	35 °C	45 °C	55 °C		
							Busbars section [mm <sup>2</sup> ]		
X1B/N/L 06	630	630	630	630	2x(40x5)	630	630	630	2x(40x5)
X1B/N/L 08	800	800	800	800	2x(50x5)	800	800	800	2x(50x5)
X1B/N/L 10	1000	1000	1000	1000	2x(50x8)	1000	1000	1000	2x(50x10)
X1L 10	1000	1000	1000	1000	2x(50x8)	1000	960	900	2x(50x10)
X1B/N/L 12	1250	1250	1250	1250	2x(50x8)	1250	1250	1200	2x(50x10)
X1L 12	1250	1250	1250	1110	2x(50x8)	1250	1150	960	2x(50x10)
X1B/N 16	1600	1600	1500	1400	2x(50x10)	1460	1400	1300	3x(50x8)

### 3 General characteristics

Type	Iu [A]	Vertical terminals			Busbars section [mm <sup>2</sup> ]	Horizontal and front terminals			
		Continuous capacity [A]				Continuous capacity [A]			
		35 °C	45 °C	55 °C		35 °C	45 °C	55 °C	
E1B/N 08	800	800	800	800	1x(60x10)	800	800	800	1x(60x10)
E1B/N 10	1000	1000	1000	1000	1x(80x10)	1000	1000	1000	2x(60x8)
E1B/N 12	1250	1250	1250	1250	1x(80x10)	1250	1250	1200	2x(60x8)
E1B/N 16	1600	1600	1600	1500	2x(60x10)	1550	1450	1350	2x(60x10)
E2S 08	800	800	800	800	1x(60x10)	800	800	800	1x(60x10)
E2N/S 10	1000	1000	1000	1000	1x(60x10)	1000	1000	1000	1x(60x10)
E2N/S 12	1250	1250	1250	1250	1x(60x10)	1250	1250	1250	1x(60x10)
E2B/N/S 16	1600	1600	1600	1600	2x(60x10)	1600	1600	1530	2x(60x10)
E2B/N/S 20	2000	2000	2000	1800	3x(60x10)	2000	2000	1750	3x(60x10)
E2L 12	1250	1250	1250	1250	1x(60x10)	1250	1250	1250	1x(60x10)
E2L 16	1600	1600	1600	1500	2x(60x10)	1600	1500	1400	2x(60x10)
E3H/V 08	800	800	800	800	1x(60x10)	800	800	800	1x(60x10)
E3S/H 10	1000	1000	1000	1000	1x(60x10)	1000	1000	1000	1x(60x10)
E3S/H/V 12	1250	1250	1250	1250	1x(60x10)	1250	1250	1250	1x(60x10)
E3S/H/V 16	1600	1600	1600	1600	1x(100x10)	1600	1600	1600	1x(100x10)
E3S/H/V 20	2000	2000	2000	2000	2x(100x10)	2000	2000	2000	2x(100x10)
E3N/S/H/V 25	2500	2500	2500	2500	2x(100x10)	2500	2450	2400	2x(100x10)
E3N/S/H/V 32	3200	3200	3100	2800	3x(100x10)	3000	2880	2650	3x(100x10)
E3L 20	2000	2000	2000	2000	2x(100x10)	2000	2000	1970	2x(100x10)
E3L 25	2500	2500	2390	2250	2x(100x10)	2375	2270	2100	2x(100x10)
E4H/V 32	3200	3200	3200	3200	3x(100x10)	3200	3150	3000	3x(100x10)
E4S/H/V 40	4000	4000	3980	3500	4x(100x10)	3600	3510	3150	6x(60x10)
E6V 32	3200	3200	3200	3200	3x(100x10)	3200	3200	3200	3x(100x10)
E6H/V 40	4000	4000	4000	4000	4x(100x10)	4000	4000	4000	4x(100x10)
E6H/V 50	5000	5000	4850	4600	6x(100x10)	4850	4510	4250	6x(100x10)
E6H/V 63	6300	6000	5700	5250	7x(100x10)	-	-	-	-

Note: the reference temperature is the ambient temperature

#### Examples:

Selection of a moulded-case circuit-breaker, with thermomagnetic release, for a load current of 180 A, at an ambient temperature of 60 °C.

From the table referring to Tmax circuit-breakers (page 205), it can be seen that the most suitable breaker is the T3 In 250, which can be set from 152 A to 216 A.

Selection of a moulded-case circuit-breaker, with electronic release, in withdrawable version with rear flat horizontal bar terminals, for a load current equal to 720 A, with an ambient temperature of 50 °C.

From the table referring to Tmax circuit-breakers (page 209), it can be seen that the most suitable breaker is the T6 800, which can be set from 320 A to 760 A.

Selection of an air circuit-breaker, with electronic release, in withdrawable version with vertical terminals, for a load current of 2700 A, with a temperature outside of the IP31 switchboard of 55 °C.

From the tables referring to the current carrying capacity inside the switchboard for Emax circuit-breakers (see above), it can be seen that the most suitable breaker is the E3 3200, with busbar section 3x(100x10)mm<sup>2</sup>, which can be set from 1280 A to 2800 A.

### 3 General characteristics

The following tables show the maximum settings for L protection (against overload) for electronic releases, according to temperature, version and terminals.

Tmax T2 In = 160A	Fixed	Plug-in
	PR221	
	All terminals	
40	1	0.9
45	0.98	0.88
50	0.96	0.84
55	0.92	0.8
60	0.88	0.76
65	0.84	0.72
70	0.8	0.68

Tmax T4 In = 250A	Fixed				Plug-in - Withdrawable			
	PR221		PR222/PR223		PR221		PR222/PR223	
	FC - F	HR - VR	FC - F	HR - VR	FC - F	HR - VR	FC - F	HR - VR
≤40	1	1	1	1	1	1	1	1
45								
50								
55								
60								
65	0.96	0.92	0.96	0.94	0.92	0.88	0.92	0.88
70	0.92	0.88	0.92	0.88	0.88	0.84	0.88	0.84

Tmax T4 In = 320A	Fixed				Plug-in - Withdrawable			
	PR221		PR222/PR223		PR221		PR222/PR223	
	FC - F	HR - VR	FC - F	HR - VR	F	FC-HR-VR	F	FC-HR-VR
≤40	1	1	1	1	1	1	1	1
45								
50								
55								
60								
65	0.96	0.92	0.96	0.92	0.96	0.92	0.96	0.92
70	0.8	0.76	0.8	0.76	0.8	0.76	0.8	0.76

FC = Front terminals for cables; F = Front flat terminals; HR = Rear flat horizontal terminals; VR = Rear flat vertical terminals.

### 3 General characteristics

Tmax T5 In = 400A	Fixed				Plug-in - Withdrawable			
	PR221		PR222/PR223		PR221		PR222/PR223	
	FC - F	HR - VR	FC - F	HR - VR	FC - F	HR - VR	FC - F	HR - VR
≤40	1	1	1	1	1	1	1	1
45								
50								
55								
60								
65	0.96	0.92	0.96	0.94	0.92	0.88	0.92	0.88
70	0.92	0.88	0.92	0.88	0.88	0.84	0.88	0.84

Tmax T5 In = 630A	Fixed				Plug-in - Withdrawable			
	PR221		PR222/PR223		PR221		PR222/PR223	
	FC - F	HR - VR	FC - F	HR - VR	F	HR-VR	F	HR-VR
≤40	1	1	1	1	1	1	1	1
45								
50								
55								
60								
65	0.96	0.92	0.96	0.92	0.96	0.92	0.96	0.92
70	0.8	0.76	0.8	0.76	0.76	0.72	0.76	0.72

FC = Front terminals for cables; F = Front flat terminals; HR = Rear flat horizontal terminals; VR = Rear flat vertical terminals.

Tmax T6 In = 630A	Fixed						Withdrawable			
	PR221			PR222/PR223			PR221		PR222/PR223	
	F	FC	R	F	FC	R	EF-VR	HR	EF-VR	HR
≤40	1	1	1	1	1	1	1	1	1	1
45										
50										
55										
60										
65	0.96	0.92	0.84	0.96	0.92	0.84	0.92	0.84	0.92	0.84
70	0.92	0.88	0.8	0.94	0.9	0.8	0.88	0.8	0.9	0.8

F = Front flat terminals; HR = Rear flat horizontal terminals; VR = Rear flat vertical terminals; FC = Front terminals for cables; R(HR) = Rear terminals oriented in horizontal; R(VR) = Rear terminals oriented in vertical; ES = Spreaded extended front terminals; R = Rear terminals; EF = Front extended.

## 3 General characteristics

Tmax T6 In = 800A	Fixed						Withdrawable					
	PR221			PR222/PR223			PR221			PR222/PR223		
	F	FC	R	F	FC	R	EF-VR	HR	EF-VR	HR		
≤40	1	1	1	1	1	1	1	1	1	1	1	
45	1	1	1	1	1	1	0.96	1	0.96	1	0.96	
50	1	1	1	1	1	1	0.92	1	0.92	1	0.94	
55	1	0.96	0.92	1	0.96	0.94	0.96	0.92	0.96	0.92	0.92	
60	1	0.92	0.88	1	0.94	0.9	0.92	0.88	0.94	0.9	0.9	
65	0.96	0.92	0.84	0.96	0.92	0.84	0.92	0.84	0.92	0.84	0.84	
70	0.92	0.88	0.8	0.94	0.9	0.8	0.88	0.8	0.9	0.8	0.8	

Tmax T6 In = 1000A	Fixed							
	PR221				PR222/PR223			
	FC	R (HR)	R (VR)	ES	FC	R (HR)	R (VR)	ES
≤40	1	1	1	1	1	1	1	1
45	1	0.96	1	0.92	1	0.96	1	0.94
50	1	0.92	0.96	0.88	1	0.92	0.96	0.9
55	0.92	0.88	0.88	0.84	0.92	0.88	0.9	0.84
60	0.92	0.84	0.88	0.8	0.92	0.84	0.88	0.82
65	0.84	0.76	0.8	0.76	0.84	0.78	0.82	0.76
70	0.8	0.76	0.76	0.72	0.8	0.76	0.78	0.72

Tmax T7 V In=1000	Fixed						Withdrawable					
	PR231/PR232		PR331		PR332		PR231/PR232		PR331		PR332	
	VR	EF-HR	VR	EF-HR	VR	EF-HR	VR	EF-HR	VR	EF-HR	VR	EF-HR
≤40	1	1	1	1	1	1	1	1	1	1	1	1
45	1	1	1	1	1	1	1	1	1	1	1	1
50	1	1	1	1	1	1	1	1	1	1	1	1
55	1	0.92	1	0.925	1	0.94	0.92	0.92	0.95	0.925	0.95	0.94
60	1	0.88	1	0.875	1	0.89	0.88	0.88	0.9	0.875	0.9	0.89
65	0.92	0.8	0.95	0.825	0.95	0.83	0.84	0.8	0.85	0.825	0.86	0.83
70	0.88	0.76	0.875	0.775	0.89	0.78	0.8	0.76	0.8	0.775	0.81	0.78

Tmax T7 S, H, L In=1250	Fixed						Withdrawable					
	PR231/PR232		PR331		PR332		PR231/PR232		PR331		PR332	
	VR	EF-HR	VR	EF-HR	VR	EF-HR	VR	EF-HR	VR	EF-HR	VR	EF-HR
≤40	1	1	1	1	1	1	1	1	1	1	1	1
45	1	1	1	1	1	1	1	1	1	1	1	1
50	1	1	1	1	1	1	1	1	1	1	1	1
55	1	0.92	1	0.925	1	0.94	0.92	0.92	0.95	0.925	0.95	0.94
60	1	0.88	1	0.875	1	0.89	0.88	0.88	0.9	0.875	0.91	0.89
65	0.92	0.84	0.925	0.825	0.94	0.84	0.84	0.84	0.85	0.825	0.86	0.84
70	0.88	0.76	0.875	0.775	0.89	0.78	0.8	0.76	0.8	0.775	0.81	0.78

## 3 General characteristics

Tmax T7 V In=1250	Fixed						Withdrawable					
	PR231/PR232		PR331		PR332		PR231/PR232		PR331		PR332	
	VR	EF-HR	VR	EF-HR	VR	EF-HR	VR	EF-HR	VR	EF-HR	VR	EF-HR
≤40	1	1	1	1	1	1	1	1	1	1	1	1
45	1	0.96	1	0.95	1	0.96	0.96	0.88	0.95	0.9	0.96	0.9
50	0.96	0.92	0.95	0.925	0.96	0.92	0.92	0.8	0.925	0.8	0.92	0.8
55	0.88	0.88	0.9	0.875	0.91	0.88	0.88	0.76	0.875	0.75	0.88	0.76
60	0.84	0.84	0.85	0.825	0.87	0.84	0.84	0.72	0.825	0.725	0.84	0.73
65	0.8	0.76	0.8	0.775	0.82	0.79	0.76	0.68	0.775	0.675	0.79	0.69
70	0.76	0.72	0.775	0.75	0.78	0.75	0.72	0.64	0.75	0.65	0.75	0.65

Tmax T7 S, H, L In=1600	Fixed						Withdrawable					
	PR231/PR232		PR331		PR332		PR231/PR232		PR331		PR332	
	VR	EF-HR	VR	EF-HR	VR	EF-HR	VR	EF-HR	VR	EF-HR	VR	EF-HR
≤40	1	1	1	1	1	1	1	1	1	1	1	1
45	1	0.96	1	0.95	1	0.96	0.96	0.88	0.95	0.9	0.96	0.9
50	0.96	0.92	0.95	0.925	0.96	0.92	0.92	0.8	0.925	0.8	0.92	0.8
55	0.88	0.88	0.9	0.875	0.91	0.88	0.88	0.76	0.875	0.75	0.88	0.76
60	0.84	0.84	0.875	0.825	0.87	0.84	0.84	0.72	0.825	0.725	0.84	0.73
65	0.8	0.76	0.825	0.775	0.83	0.79	0.8	0.68	0.8	0.675	0.8	0.67
70	0.76	0.72	0.775	0.75	0.78	0.75	0.72	0.64	0.75	0.65	0.75	0.65

F = Front flat terminals; HR = Rear flat horizontal terminals; VR = Rear flat vertical terminals; FC = Front terminals for cables; R(HR) = Rear terminals oriented in horizontal; R(VR) = Rear terminals oriented in vertical; ES = Spreaded extended front terminals; R = Rear terminals; EF = Front extended.

Isomax S7 In ≤ 1250A	Front flat bar		Front flat bar		Front for cables		Rear horizontal flat bar		Rear horizontal flat bar	
	Rear vertical flat bar		Rear vertical flat bar		Front for cables		Rear horizontal flat bar		Rear horizontal flat bar	
	PR211		PR212		PR211		PR211		PR212	
≤40	F	W	F	W	F	F	F	W	F	W
45	1	1	1	1	1	1	1	1	1	1
50	1	1	1	1	1	1	1	1	1	1
55	1	0.95	1	0.975	0.95	0.975	1	0.95	1	0.95
60	1	0.88	1	0.875	0.9	0.875	1	0.9	1	0.9
65	0.95	0.8	0.975	0.975	0.9	0.925	0.95	0.8	0.95	0.85
70	0.95	0.76	0.95	0.9	0.9	0.9	0.9	0.8	0.9	0.8

Isomax S7 In = 1600A	Front flat bar		Front flat bar		Rear horizontal flat bar		Rear horizontal flat bar	
	Rear vertical flat bar		Rear vertical flat bar		Rear horizontal flat bar		Rear horizontal flat bar	
	PR211		PR212		PR211		PR212	
≤40	F	W	F	W	F	W	F	W
45	1	1	1	1	1	1	1	1
50	0.95	0.95	0.975	0.95	0.95	0.9	0.95	0.9
55	0.9	0.8	0.925	0.85	0.8	0.7	0.85	0.75
60	0.9	0.8	0.9	0.8	0.8	0.7	0.8	0.7
65	0.95	0.7	0.85	0.75	0.7	0.6	0.75	0.65
70	0.95	0.7	0.8	0.7	0.7	0.6	0.7	0.6



### 3 General characteristics

Emax X1	630 A	
	PR331	PR332/PR333
≤40	1	1
45		
50		
55		
60		

Emax X1	800 A	
	PR331	PR332/PR333
≤40	1	1
45		
50		
55		
60		

Emax X1	1000 A	
	PR331	PR332/PR333
≤40	1	1
45		
50		
55		
60		

Emax X1	1250 A	
	PR331	PR332/PR333
≤40	1	1
45		
50		
55		
60		

Emax X1*	1600 A	
	PR331	PR332/PR333
≤40	1	1
45		
50		
55		
60		
60		

Emax X1**	1600 A	
	PR331	PR332/PR333
≤40	1	1
45		
50		
55		
60		
60		

\* with horizontal rear terminals

\*\* with vertical rear terminals

### 3 General characteristics

Emax E1	800 A	
	PR121	PR122/PR123
≤40	1	1
45		
50		
55		
60		
65		
70		

Emax E1	1000 A	
	PR121	PR122/PR123
≤40	1	1
45		
50		
55		
60		
65		
70		

Emax E1	1250 A	
	PR121	PR122/PR123
≤40	1	1
45		
50		
55		
60		
65		
70		

Emax E1	1600 A	
	PR121	PR122/PR123
≤40	1	1
45	0.975	0.98
50	0.95	0.95
55	0.925	0.93
60	0.9	0.91
65	0.875	0.89
70	0.85	0.87

Emax E2	800/1000/1250 A	
	PR121	PR122/PR123
≤40	1	1
45		
50		
55		
60		
65		
70		

Emax E2	1600 A	
	PR121	PR122/PR123
≤40	1	1
45		
50		
55		
60		
65		
70		

Emax E2	2000 A	
	PR121	PR122/PR123
≤40	1	1
45	0.95	0.97
50		
55		
60		
65		
70		

Emax E3	800/1000/1250/1600/2000 A	
	PR121	PR122/PR123
≤40	1	1
45		
50		
55		
60		
65		
70		

### 3 General characteristics

Emax E3	2500 A	
	PR121	PR122/PR123
≤40	1	1
45		
50		
55		
60		
65		
70		
	0.95	0.97
	0.925	0.94

Emax E3	3200 A	
	PR121	PR122/PR123
≤40	1	1
45		
50		
55		
60		
65		
70		
	0.95	0.96
	0.9	0.92
	0.875	0.89
	0.85	0.85
	0.8	0.82

Emax E4	3200 A	
	PR121	PR122/PR123
≤40	1	1
45		
50		
55		
60		
65		
70		
	0.975	0.97
	0.95	0.95

Emax E4	4000 A	
	PR121	PR122/PR123
≤40	1	1
45		
50		
55		
60		
65		
70		
	0.975	0.97
	0.925	0.94
	0.9	0.92
	0.875	0.89
	0.85	0.86

Emax E6	3200/4000 A	
	PR121	PR122/PR123
≤40	1	1
45		
50		
55		
60		
65		
70		

Emax E6	5000 A	
	PR121	PR122/PR123
≤40	1	1
45		
50		
55		
60		
65		
70		
	0.975	0.98
	0.95	0.96
	0.925	0.94

Emax E6	6300 A	
	PR121	PR122/PR123
≤40	1	1
45		
50		
55		
60		
65		
70		
	0.975	0.98
	0.95	0.96
	0.9	0.92
	0.875	0.88

### 3 General characteristics

For switchboards with the following dimensions (mm):2000x400x400 (HxLxD)

	Vertical terminals					
	35 °C		45 °C		55 °C	
	PR331	PR332/PR333	PR331	PR332/PR333	PR331	PR332/PR333
X1B/N/L 06	1	1	1	1	1	1
X1B/N/L 08						
X1B/N 10						
X1L 10					0.95	0.96
X1B/N 12					1	1
X1L 12					0.95	0.96
X1B/N 16					0.9	0.9
			0.875	0.88		
			0.825	0.83		

	Horizontal and front terminals							
	35 °C		45 °C		55 °C			
	PR331	PR332/PR333	PR331	PR332/PR333	PR331	PR332/PR333		
X1B/N/L 06	1	1	1	1	1	1		
X1B/N/L 08								
X1B/N 10								
X1L 10					0.95	0.95	0.875	0.89
X1B/N 12					1	1	0.95	0.96
X1L 12					0.9	0.9	0.75	0.76
X1B/N 16					0.875	0.87	0.825	0.83

For switchboards with the following dimensions (mm):2300x900x800 (HxLxD)

	Vertical terminals							
	35 °C		45 °C		55 °C			
	PR331	PR332/PR333	PR331	PR332/PR333	PR331	PR332/PR333		
X1B/N/L 06	1	1	1	1	1	1		
X1B/N/L 08								
X1B/N 10								
X1L 10							0.875	0.88
X1B/N 12								
X1L 12							0.925	0.93
X1B/N 16							0.875	0.87

	Horizontal and front terminals							
	35 °C		45 °C		55 °C			
	PR331	PR332/PR333	PR331	PR332/PR333	PR331	PR332/PR333		
X1B/N/L 06	1	1	1	1	1	1		
X1B/N/L 08								
X1B/N 10								
X1L 10					0.95	0.96	0.9	0.9
X1B/N 12					1	1	0.95	0.96
X1L 12					0.9	0.92	0.75	0.76
X1B/N 16					0.9	0.91	0.875	0.87

### 3 General characteristics

	Vertical Terminals					
	35 °C		45 °C		55 °C	
	PR121	PR122/PR123	PR121	PR122/PR123	PR121	PR122/PR123
E1B/N 08	1	1	1	1	1	1
E1B/N 10	1	1	1	1	1	1
E1B/N 12	1	1	1	1	1	1
E1B/N 16	1	1	1	1	0.925	0.93
E2S 08	1	1	1	1	1	1
E2N/S 10	1	1	1	1	1	1
E2N/S 12	1	1	1	1	1	1
E2B/N/S16	1	1	1	1	1	1
E2B/N/S20	1	1	1	1	0.9	0.9
E2L 12	1	1	1	1	1	1
E2L 16	1	1	1	1	0.925	0.93
E3H/V 08	1	1	1	1	1	1
E3S/ V 10	1	1	1	1	1	1
E3S/H/V 12	1	1	1	1	1	1
E3S/H/V 16	1	1	1	1	1	1
E3S/H/V20	1	1	1	1	1	1
E3N/S/H/ V25	1	1	1	1	1	1
E3N/S/H/ V32	1	1	0.95	0.96	0.875	0.87
E3L 20	1	1	1	1	1	1
E3L 25	1	1	0.95	0.95	0.9	0.9
E4H/V32	1	1	1	1	1	1
E4S/H/V40	1	1	0.975	0.99	0.875	0.87
E6V 32	1	1	1	1	1	1
E6H/ V 40	1	1	1	1	1	1
E6H/ V 50	1	1	0.95	0.97	0.9	0.92
E6H/V 63	0.95	0.95	0.9	0.9	0.825	0.83

	Horizontal and front Terminals					
	35 °C		45 °C		55 °C	
	PR121	PR122/PR123	PR121	PR122/PR123	PR121	PR122/PR123
E1B/N 08	1	1	1	1	1	1
E1B/N 10	1	1	1	1	1	1
E1B/N 12	1	1	1	1	0.95	0.96
E1B/N 16	0.95	0.96	0.9	0.9	0.825	0.84
E2S 08	1	1	1	1	1	1
E2N/S 10	1	1	1	1	1	1
E2N/S 12	1	1	1	1	1	1
E2B/N/S16	1	1	1	1	0.95	0.95
E2B/N/S20	1	1	1	1	0.875	0.87
E2L 12	1	1	1	1	1	1
E2L 16	1	1	0.925	0.93	0.875	0.87
E3H/ V 08	1	1	1	1	1	1
E3S/H 10	1	1	1	1	1	1
E3S/H/ V 12	1	1	1	1	1	1
E3S/H/ V16	1	1	1	1	1	1
E3S/H/ V20	1	1	1	1	1	1
E3N/S/H/ V25	1	1	0.975	0.98	0.95	0.96
E3N/S/H/ V32	0.925	0.93	0.9	0.9	0.825	0.82
E3L 20	1	1	1	1	0.975	0.98
E3L 25	0.95	0.95	0.9	0.9	0.825	0.84
E4H/ V32	1	1	0.975	0.98	0.925	0.93
E4S/H/ V40	0.9	0.9	0.875	0.87	0.775	0.78
E6V 32	1	1	1	1	1	1
E6H/ V 40	1	1	1	1	1	1
E6H/ V 50	0.95	0.97	0.9	0.9	0.85	0.85
E6H/ V 63	-	-	-	-	-	-

### 3 General characteristics

#### 3.6 Altitude derating

For installations carried out at altitudes of more than 2000 m above sea level, the performance of low voltage circuit-breakers is subject to a decline.

Basically there are two main phenomena:

- the reduction of air density causes a lower efficiency in heat transfer. The allowable heating conditions for the various parts of the circuit-breaker can only be followed if the value of the rated uninterrupted current is decreased;
- the rarefaction of the air causes a decrease in dielectric rigidity, so the usual isolation distances become insufficient. This leads to a decrease in the maximum rated voltage at which the device can be used.

The correction factors for the different types of circuit-breakers, both moulded- case and air circuit-breakers, are given in the following table:

Altitude	Rated operational voltage Ue [V]			
	2000[m]	3000[m]	4000[m]	5000[m]
Tmax*	690	600	500	440
Isomax	690	600	500	440
Emax	690	600	500	440

Altitude	Rated uninterrupted current Iu [A]			
	2000[m]	3000[m]	4000[m]	5000[m]
Tmax	100%	98%	93%	90%
Isomax	100%	95%	90%	85%
Emax	100%	98%	93%	90%

\*Excluding Tmax T1P

## 3 General characteristics

### 3.7 Electrical characteristics of switch disconnectors

A switch disconnector as defined by the standard IEC 60947-3 is a mechanical switching device which, when in the open position, carries out a disconnecting function and ensures an isolating distance (distance between contacts) sufficient to guarantee safety. This safety of disconnection must be guaranteed and verified by the positive operation: the operating lever must always indicate the actual position of the mobile contacts of the device.

The mechanical switching device must be able to make, carry and break currents in normal circuit conditions, including any overload currents in normal service, and to carry, for a specified duration, currents in abnormal circuit conditions, such as, for example, short-circuit conditions.

Switch disconnectors are often used as:

- main sub-switchboard devices;
- switching and disconnecting devices for lines, busbars or load units;
- bus-tie.

The switch disconnector shall ensure that the whole plant or part of it is not live, safely disconnecting from any electrical supply. The use of such a switch disconnector allows, for example, personnel to carry out work on the plant without risks of electrical nature.

Even if the use of a single pole devices side by side is not forbidden, the standards recommend the use of multi-pole devices so as to guarantee the simultaneous isolation of all poles in the circuit.

The specific rated characteristics of switch disconnectors are defined by the standard IEC 60947-3, as detailed below:

- **I<sub>cw</sub> [kA]:** rated short-time withstand current:  
is the current that a switch is capable of carrying, without damage, in the closed position for a specific duration
- **I<sub>cm</sub> [kA]:** rated short-circuit making capacity:  
is the maximum peak value of a short-circuit current which the switch disconnector can close without damages. When this value is not given by the manufacturer it must be taken to be at least equal to the peak current corresponding to I<sub>cw</sub>. It is not possible to define a breaking capacity I<sub>cu</sub> [kA] since switch disconnectors are not required to break short-circuit currents
- **utilization categories with alternating current AC and with direct current DC:**

define the kind of the conditions of using which are represented by two letters to indicate the type of circuit in which the device may be installed (AC for alternating current and DC for direct current), with a two digit number for the type of load which must be operated, and an additional letter (A or B) which represents the frequency in the using.

With reference to the utilization categories, the product standard defines the current values which the switch disconnector must be able to break and make under abnormal conditions.

## 3 General characteristics

The characteristics of the utilization categories are detailed in Table 1 below. The most demanding category in alternating current is AC23A, for which the device must be capable of connecting a current equal to 10 times the rated current of the device, and of disconnecting a current equal to 8 times the rated current of the device.

From the point of view of construction, the switch disconnector is a very simple device. It is not fitted with devices for overcurrent detection and the consequent automatic interruption of the current. Therefore the switch disconnector cannot be used for automatic protection against overcurrent which may occur in the case of failure, protection must be provided by a coordinated circuit-breaker. The combination of the two devices allows the use of switch disconnectors in systems in which the short-circuit current value is greater than the electrical parameters which define the performance of the disconnector (back-up protection see Chapter 4.4. This is valid only for Isomax and Tmax switch-disconnectors. For the Emax/MS air disconnectors, it must be verified that the values for I<sub>cw</sub> and I<sub>cm</sub> are higher to the values for short-circuit in the plant and correspondent peak, respectively.

**Table1: Utilization categories**

Nature of current	Utilization categories		
	Utilization category		Typical applications
	Frequent operation	Non-frequent operation	
Alternating Current	AC-20A	AC-20B	Connecting and disconnecting under no-load conditions
	AC-21A	AC-21B	Switching of resistive loads including moderate overloads
	AC-22A	AC-22B	Switching of mixed resistive and inductive loads, including moderate overload
	AC-23A	AC-23B	Switching of motor loads or other highly inductive loads
Direct Current	DC-20A	DC-20B	Connecting and disconnecting under no-load conditions
	DC-21A	DC-21B	Switching of resistive loads including moderate overloads
	DC-22A	DC-22B	Switching of mixed resistive and inductive loads, including moderate overload (e.g. shunt motors)
	DC-23A	DC-23B	Switching of highly inductive loads

### 3 General characteristics

Tables 2, 3 and 4 detail the main characteristics of the disconnectors.

**Table 2: Tmax switch disconnectors**

		Tmax T1D	Tmax T3D		
Conventional thermal current, <b>I<sub>th</sub></b>	[A]	160	250		
Rated service current in category AC22, <b>I<sub>e</sub></b>	[A]	160	250		
Rated service current in category AC23, <b>I<sub>e</sub></b>	[A]	125	200		
Poles	[Nr.]	3/4	3/4		
Rated service voltage, <b>U<sub>e</sub></b>	(AC) 50-60 Hz	690	690		
	(DC)	500	500		
Rated impulse withstand voltage, <b>U<sub>imp</sub></b>	[kV]	8	8		
Rated insulation voltage, <b>U<sub>i</sub></b>	[V]	800	800		
Test voltage at industrial frequency for 1 minute	[V]	3000	3000		
Rated short-circuit making capacity, I <sub>cm</sub> (min) switch-disconnector only	[kA]	2.8	5.3		
	(max) with circuit-breaker on supply side	[kA]	187	105	
Rated short-time withstand current for 1s, <b>I<sub>cw</sub></b>	[kA]	2	3.6		
Reference Standard		IEC 60947-3	IEC 60947-3		
Versions		F	F - P		
Terminals		FC Cu - EF - FC CuAl	F-FC CuAl-FC Cu-EF-ES-R		
Mechanical life	[No. operations]	25000	25000		
	[No. Hourly operations]	120	120		
Basic dimensions, fixed	3 poles	W [mm]	76	105	
	4 poles	W [mm]	102	140	
		D [mm]	70	70	
	H [mm]	130	150		
Weight	fixed	3/4 poles	[kg]	0.9/1.2	1.5/2
	plug-in	3/4 poles	[kg]	-	2.1/3.7
	withdrawable	3/4 poles	[kg]	-	-

### 3 General characteristics

Tmax T4D	Tmax T5D	Tmax T6D	Tmax T7D
250/320	400/630	630/800/1000	1000/1250/1600
250/320	400/630	630/800/1000	1000/1250/1600
250	400	630/800/800	1000/1250/1250
3/4	3/4	3/4	3/4
690	690	690	690
750	750	750	750
8	8	8	8
800	800	1000	1000
3000	3000	3500	3000
5.3	11	30	52.5
440	440	440	440
3.6	6	15	20
IEC 60947-3	IEC 60947-3	IEC 60947-3	IEC 60947-3
F - P - W	F - P - W	F-W	F-W
F-FC CuAl-FC Cu-EF-ES-R-MC-HR-VR	F-FC CuAl-FC Cu-EF-ES-R-HR-VR	F-FC CuAl-EF-ES-R-RC	F-EF-ES-FC CuAl HR/VR
20000	20000	20000	10000
120	120	120	60
105	140	210	210
140	184	280	280
103.5	103.5	268	154(manual)/178(motorizable)
205	205	103.5	268
2.35/3.05	3.25/4.15	9.5/12	9.7/12.5(manual)/11/14(motorizable)
3.6/4.65	5.15/6.65	-	-
3.85/4.9	5.4/6.9	12.1/15.1	29.7/39.6(manual)/32/42.6(motorizable)

KEY TO VERSIONS  
F = Fixed  
P = Plug-in  
W = Withdrawable

KEY TO TERMINALS  
F = Front  
EF = Extended front  
ES = Extended spreaded front

FC CuAl = Front for copper or aluminium cables  
R = Rear threaded  
RC = Rear for copper or aluminium cables  
HR = Rear horizontal flat bar

VR = Rear vertical flat bar

### 3 General characteristics

**Table 3: SACE Isomax switch disconnectors**

Conventional thermal current at 40 °C, <b>I<sub>th</sub></b>	[A]
Number of poles	Nr.
Rated operational voltage, <b>U<sub>e</sub></b>	(ac) 50-60Hz [V~] (dc) [V-]
Rated current, <b>I<sub>e</sub></b>	[A]
Rated impulse withstand voltage, <b>U<sub>imp</sub></b>	[kV]
Rated insulation voltage, <b>U<sub>i</sub></b>	[V]
Test voltage at industrial frequency for 1 min.	[V]
Rated short-circuit making capacity (415 V~), <b>I<sub>cm</sub></b>	[kA]
Rated short-time withstand current for 1 s, <b>I<sub>cw</sub></b>	[kA]
Isolation behaviour	
IEC 60947-3	
Versions	
Terminals	fixed  plug-in withdrawable
Mechanical life [No. of operations / operation per hour]	
Basic dimensions, fixed	L (3/4 poles) [mm] D [mm] H [mm]
Weight, fixed	3/4 poles [kg]

**Table 4: Emax switch disconnectors**

		X1B/MS	E1B/MS	E1N/MS	E2B/MS	E2N/MS	E2S/MS	E3N/MS	E3S/MS	E3V/MS	E4S/MS	E4H/fMS	E4H/MS	E6H/MS	E6H/f MS
<b>Rated uninterrupted current (a 40 °C) I<sub>w</sub></b>	[A]	1000	800	800	1600	1000	1000	2500	1000	800	4000	3200	3200	4000	4000
	[A]	1250	1000	1000	2000	1250	1250	3200	1250	1250		4000	4000	5000	5000
	[A]	1600	1250	1250		1600	1600		1600	1600				6300	6300
	[A]		1600	1600		2000	2000		2000	2000					
	[A]							2500	2500						
	[A]							3200	3200						
<b>Rated operational voltage U<sub>e</sub></b>	[V ~]	690	690	690	690	690	690	690	690	690	690	690	690	690	690
	[V -]	250	250	250	250	250	250	250	250	250	250	250	250	250	250
<b>Rated insulation voltage U<sub>i</sub></b>	[V ~]	1000	1000	1000	1000	1000	1000	1000	1000	1000	1000	1000	1000	1000	1000
<b>Rated impulse withstand voltage U<sub>imp</sub></b>	[kV]	12	12	12	12	12	12	12	12	12	12	12	12	12	12
<b>Rated short-time withstand current I<sub>cw</sub></b>	(1s) [kA]	42	42	50 <sup>(1)</sup>	42	55	65	65	75	85	75	85	100 <sup>(2)</sup>	100	100
	(3s) [kA]		36	36	42	42	42	65	65	65	75	75	75	85	85
<b>Rated short-circuit making capacity (peak value) I<sub>cm</sub></b>	220/230/380/400/415/440 V ~ [kA]	88.2	88.2	105	88.2	143	187	143	165	286	165	220	220	220	220
	500/660/690 V ~ [kA]	88.2	5.6	75.6	88.2	121	143	143	165	220	165	220	187	220	220

**Note:** the breaking capacity  $I_{cw}$ , at the maximum rated use voltage, by means of external protection relay, with 500 ms maximum timing, is equal to the value of  $I_{cw}$  (1s).

<sup>(1)</sup>  $I_{cw} = 36kA@690V$ .

<sup>(2)</sup>  $I_{cw} = 85kA@690V$ .

### 3 General characteristics

**S7D**

Conventional thermal current at 40 °C, <b>I<sub>th</sub></b>	1000 / 1250 / 1600
Number of poles	3/4
Rated operational voltage, <b>U<sub>e</sub></b>	690 750
Rated current, <b>I<sub>e</sub></b>	1000-1250-1600
Rated impulse withstand voltage, <b>U<sub>imp</sub></b>	8
Rated insulation voltage, <b>U<sub>i</sub></b>	800
Test voltage at industrial frequency for 1 min.	3000
Rated short-circuit making capacity (415 V~), <b>I<sub>cm</sub></b>	52,5
Rated short-time withstand current for 1 s, <b>I<sub>cw</sub></b>	25
Isolation behaviour	■
IEC 60947-3	■
Versions	F - W
Terminals	F - EF - FC CuAl (1250A) HR - VR - F - HR - VR
Mechanical life [No. of operations / operation per hour]	10000/120
Basic dimensions, fixed	210/280 138,5 406
Weight, fixed	17/22

## 4 Protection coordination

### 4.1 Protection coordination

The design of a system for protecting an electric network is of fundamental importance both to ensure the correct economic and functional operation of the installation as a whole and to reduce to a minimum any problem caused by anomalous operating conditions and/or malfunctions.

The present analysis discusses the coordination between the different devices dedicated to the protection of zones and specific components with a view to:

- guaranteeing safety for people and installation at all times;
- identifying and rapidly excluding only the zone affected by a problem, instead of taking indiscriminate actions and thus reducing the energy available to the rest of the network;
- containing the effects of a malfunction on other intact parts of the network (voltage dips, loss of stability in the rotating machines);
- reducing the stress on components and damage in the affected zone;
- ensuring the continuity of the service with a good quality feeding voltage;
- guaranteeing an adequate back-up in the event of any malfunction of the protective device responsible for opening the circuit;
- providing staff and management systems with the information they need to restore the service as rapidly as possible and with a minimal disturbance to the rest of the network;
- achieving a valid compromise between reliability, simplicity and cost effectiveness.

To be more precise, a valid protection system must be able to:

- understand what has happened and where it has happened, discriminating between situations that are anomalous but tolerable and faults within a given zone of influence, avoiding unnecessary tripping and the consequent unjustified disconnection of a sound part of the system;
- take action as rapidly as possible to contain damage (destruction, accelerated ageing, ...), safeguarding the continuity and stability of the power supply.

The most suitable solution derives from a compromise between these two opposing needs - to identify precisely the fault and to act rapidly - and is defined in function of which of these two requirements takes priority.

### Over-current coordination

#### Influence of the network's electrical parameters (rated current and short-circuit current)

The strategy adopted to coordinate the protective devices depends mainly on the rated current ( $I_n$ ) and short-circuit current ( $I_k$ ) values in the considered point of network.

Generally speaking, we can classify the following types of coordination:

- current discrimination;
- time (or time-current) discrimination;
- zone (or logical) discrimination;
- energy discrimination;
- back-up.

## 4 Protection coordination

### Definition of discrimination

The **over-current discrimination** is defined in the Standards as *"coordination of the operating characteristics of two or more over-current protective devices such that, on the incidence of over-currents within stated limits, the device intended to operate within these limits does so, while the others do not operate"* (IEC 60947-1, def. 2.5.23);

It is possible to distinguish between:

- **total discrimination**, which means *"over-current discrimination such that, in the case of two over-current protective devices in series, the protective device on the load side provides protection without tripping the other protective device"* (IEC 60947-2, def. 2.17.2);
- **partial discrimination**, which means *"over-current discrimination such that, in the case of two over-current protective devices in series, the protective device on the load side provides protection up to a given over-current limit without tripping the other"* (IEC 60947-2, def. 2.17.3); this over-current threshold is called *"discrimination limit current  $I_s$ "* (IEC 60947-2, def. 2.17.4).

### Current discrimination

This type of discrimination is based on the observation that the closer the fault comes to the network's feeder, the greater the short-circuit current will be. We can therefore pinpoint the zone where the fault has occurred simply by calibrating the instantaneous protection of the device upstream to a limit value higher than the fault current which causes the tripping of the device downstream.

We can normally achieve total discrimination only in specific cases where the fault current is not very high (and comparable with the device's rated current) or where a component with high impedance is between the two protective devices (e.g. a transformer, a very long or small cable...) giving rise to a large difference between the short-circuit current values.

This type of coordination is consequently feasible mainly in final distribution networks (with low rated current and short-circuit current values and a high impedance of the connection cables).

The devices' time-current tripping curves are generally used for the study.

This solution is:

- rapid;
- easy to implement;
- and inexpensive.

On the other hand:

- the discrimination limits are normally low;
- increasing the discrimination levels causes a rapid growing of the device sizes.

The following example shows a typical application of current discrimination based on the different instantaneous tripping threshold values of the circuit-breakers considered.

## 4 Protection coordination

With a fault current value at the defined point equal to 1000 A, an adequate coordination is obtained by using the considered circuit-breakers as verified in the tripping curves of the protection devices.

The discrimination limit is given by the minimum magnetic threshold of the circuit-breaker upstream, T1B160 In160.

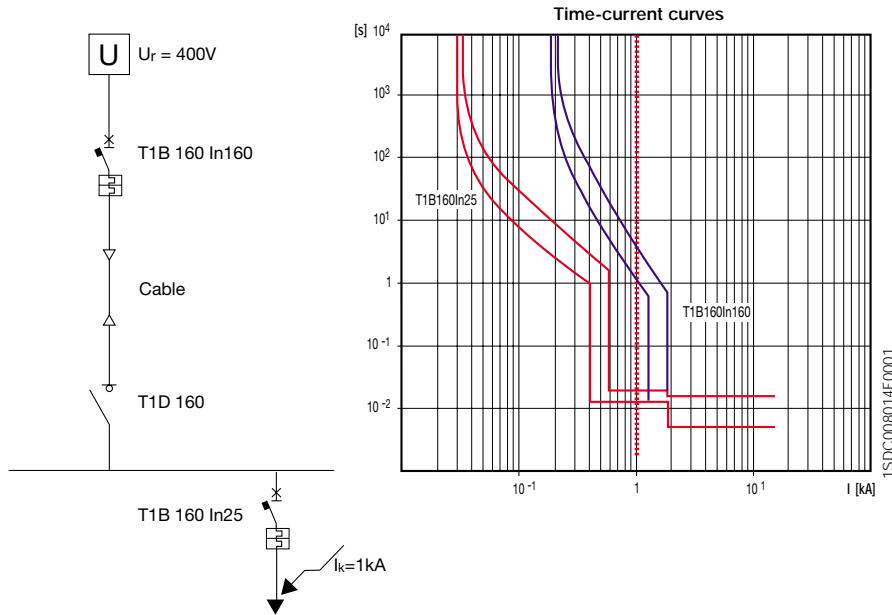

### Time discrimination

This type of discrimination is an evolution from the previous one. The setting strategy is therefore based on progressively increasing the current thresholds and the time delays for tripping the protective devices as we come closer to the power supply source. As in the case of current discrimination, the study is based on a comparison of the time-current tripping curves of the protective devices.

#### **This type of coordination:**

- is easy to study and implement;
- is relatively inexpensive;
- enables to achieve even high discrimination levels, depending on the  $I_{cw}$  of the upstream device;
- allows a redundancy of the protective functions and can send valid information to the control system,

#### **but has the following disadvantages:**

- the tripping times and the energy levels that the protective devices (especially those closer to the sources) let through are high, with obvious problems concerning safety and damage to the components even in zones unaffected by the fault;

## 4 Protection coordination

- it enables the use of current-limiting circuit-breakers only at levels hierarchically lower down the chain; the other circuit-breakers have to be capable of withstanding the thermal and electro-dynamic stresses related to the passage of the fault current for the intentional time delay. Selective circuit-breakers, often air type, have to be used for the various levels to guarantee a sufficiently high short-time withstand current;
- the duration of the disturbance induced by the short-circuit current on the power supply voltages in the zones unaffected by the fault can cause problems with electronic and electro-mechanical devices (voltage below the electromagnetic releasing value);
- the number of discrimination levels is limited by the maximum time that the network can stand without loss of stability.

The following example shows a typical application of time discrimination obtained by setting differently the tripping times of the different protection devices.

Electronic release:	L (Long delay)	S (Short delay)	I (IST)
E4S 4000 PR121-LSI In4000	Setting: 0.9 Curve: 12s	Setting: 8.5 Curve: 0.5s	Off
E3N 2500 PR121-LSI In2500	Setting: 1 Curve: 3s	Setting: 10 Curve: 0.3s	Off
S7H 1600 PR211-LI In1600	Setting: 1 Curve: A		Setting: 10

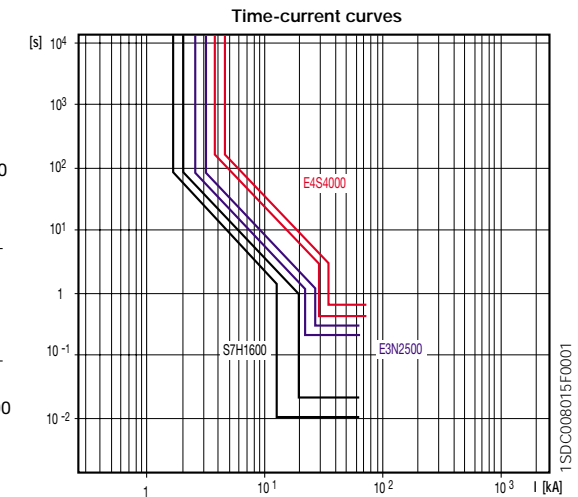
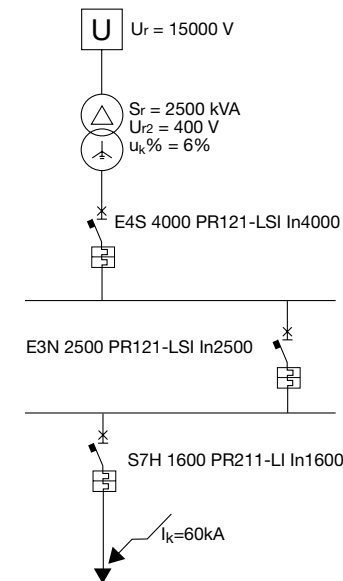



## 4 Protection coordination

### Zone (or logical) discrimination

The zone discrimination is available with MCCB (T4 L-T5 L-T6 L with PR223-EF) and ACB (with PR332/P - PR333/P - PR122 - PR 123).

This type of coordination is implemented by means of a dialogue between current measuring devices that, when they ascertain that a setting threshold has been exceeded, give the correct identification and disconnection only of the zone affected by the fault.

In practice, it can be implemented in two ways:

- the releases send information on the preset current threshold that has been exceeded to the supervisor system and the latter decides which protective device has to trip;
- in the event of current values exceeding its setting threshold, each protective device sends a blocking signal via a direct connection or bus to the protective device higher in the hierarchy (i.e. upstream with respect to the direction of the power flow) and, before it trips, it makes sure that a similar blocking signal has not arrived from the protective device downstream; in this way, only the protective device immediately upstream of the fault trips.

The first mode foresees tripping times of about one second and is used mainly in the case of not particularly high short-circuit currents where a power flow is not uniquely defined.

The second mode enables distinctly shorter tripping times: with respect to a time discrimination coordination, there is no longer any need to increase the intentional time delay progressively as we move closer to the source of the power supply. The maximum delay is in relation to the time necessary to detect any presence of a blocking signal sent from the protective device downstream.

#### Advantages:

- reduction of the tripping times and increase of the safety level;
- reduction of both the damages caused by the fault as well of the disturbances in the power supply network;
- reduction of the thermal and dynamic stresses on the circuit-breakers and on the components of the system;
- large number of discrimination levels;
- redundancy of protections: in case of malfunction of zone discrimination, the tripping is ensured by the settings of the other protection functions of the circuit-breakers. In particular, it is possible to adjust the time-delay protection functions against short-circuit at increasing time values, the closer they are to the network's feeder.

#### Disadvantages:

- higher costs;
- greater complexity of the system (special components, additional wiring, auxiliary power sources, ...).

This solution is therefore used mainly in systems with high rated current and high short-circuit current values, with precise needs in terms of both safety and continuity of service: in particular, examples of logical discrimination can be often found in primary distribution switchboards, immediately downstream of transformers and generators and in meshed networks.

## 4 Protection coordination

### Zone selectivity with Emax

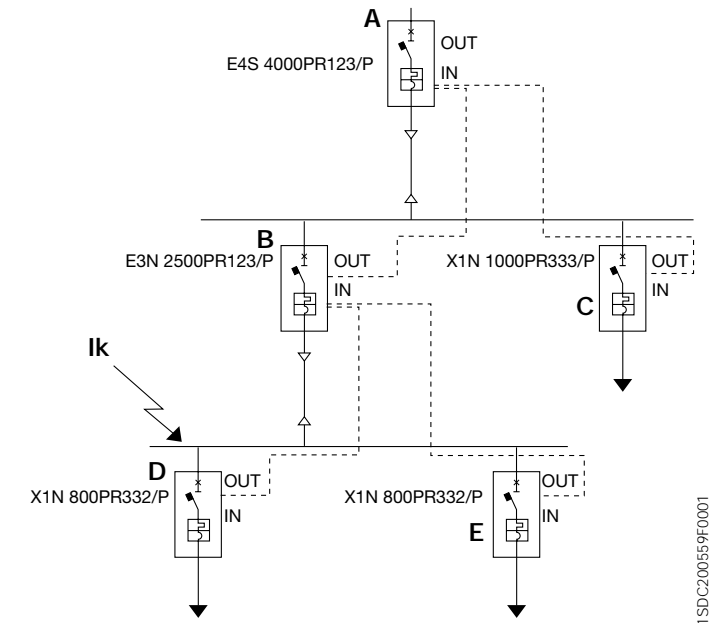

The example above shows a plant wired so as to guarantee zone selectivity with Emax CB equipped with PR332/P-PR333/P-PR122/P-PR123/P releases. Each circuit-breaker detecting a fault sends a signal to the circuit-breaker immediately on the supply side through a communication wire; the circuit-breaker that does not receive any communication from the circuit-breakers on the load side shall launch the opening command.

In this example, with a fault located in the indicated point, the circuit-breakers D and E do not detect the fault and therefore they do not communicate with the circuit-breaker on the supply side (circuit-breaker B), which shall launch the opening command within the selectivity time set from 40 to 200 ms.

To actuate correctly zone selectivity, the following settings are suggested:

S	$t_2 \geq \text{selectivity time} + 70 \text{ ms}$
I	$I_3 = \text{OFF}$
G	$t_4 \geq \text{selectivity time} + 70 \text{ ms}$
Selectivity time	same settings for each circuit-breaker

## 4 Protection coordination

### Zone selectivity for circuit-breakers type Tmax (T4L-T5L-T6L) with PR223 EF releases

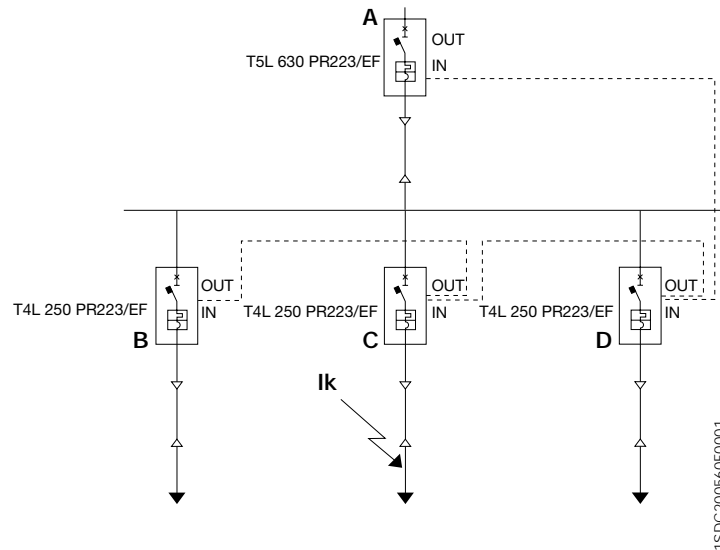

The example above shows a plant wired through an interlocking protocol (Interlocking, IL), so as to guarantee zone selectivity through PR223 EF release. In case of short-circuit, the circuit-breaker immediately on the supply side of the fault sends through the bus a block signal to the protection device hierarchically higher and verifies, before tripping, that an analogous block signal has not been sent by the protection on the load side.

In the example in the figure, the circuit-breaker C, immediately on the supply side of the fault, sends a block signal to the circuit-breaker A, which is hierarchically higher. If, as in the given example, no protection on the load side is present, the circuit-breaker C shall open in very quick times since it has received no block signal.

Everything occurs in shorter times (10 to 15ms) than in the case of zone selectivity with the Emax series air circuit-breaker (40 to 200ms), thus subjecting the plant to lower electrodynamic stresses, and with a consequent cost reduction for the plant.

## 4 Protection coordination

### Energy discrimination

Energy coordination is a particular type of discrimination that exploits the current-limiting characteristics of moulded-case circuit-breakers. It is important to remember that a current-limiting circuit-breaker is "a circuit-breaker with a break time short enough to prevent the short-circuit current reaching its otherwise attainable peak value" (IEC 60947-2, def. 2.3).

In practice, ABB SACE moulded-case circuit-breakers of Isomax and Tmax series, under short-circuit conditions, are extremely rapid (tripping times of about some milliseconds) and therefore it is impossible to use the time-current curves for the coordination studies.

The phenomena are mainly dynamic (and therefore proportional to the square of the instantaneous current value) and can be described by using the specific let-through energy curves.

In general, it is necessary to verify that the let-through energy of the circuit-breaker downstream is lower than the energy value needed to complete the opening of the circuit-breaker upstream.

This type of discrimination is certainly more difficult to consider than the previous ones because it depends largely on the interaction between the two devices placed in series and demands access to data often unavailable to the end user. Manufacturers provide tables, rules and calculation programs in which the minimum discrimination limits are given between different combinations of circuit-breakers.

#### Advantages:

- fast breaking, with tripping times which reduce as the short-circuit current increases;
- reduction of the damages caused by the fault (thermal and dynamic stresses), of the disturbances to the power supply system, of the costs...;
- the discrimination level is no longer limited by the value of the short-time withstand current  $I_{cw}$  which the devices can withstand;
- large number of discrimination levels;
- possibility of coordination of different current-limiting devices (fuses, circuit-breakers,...) even if they are positioned in intermediate positions along the chain.

#### Disadvantage:

- difficulty of coordination between circuit-breakers of similar sizes.

This type of coordination is used above all for secondary and final distribution networks, with rated currents below 1600A.

### Back-up protection

The back-up protection is an "over-current coordination of two over-current protective devices in series where the protective device, generally but not necessarily on the supply side, effects the over-current protection with or without the assistance of the other protective device and prevents any excessive stress on the latter" (IEC 60947-1, def. 2.5.24).

Besides, IEC 60364-4-43, 434.5.1 states: "... A lower breaking capacity is admitted if another protective device having the necessary breaking capacity is installed on the supply side. In that case, characteristics of the devices, must be co-ordinated so that the energy let through by these two devices does not exceed that which can be withstood without damage by the device on the load side and the conductors protected by these devices."

## 4 Protection coordination

### Advantages:

- cost-saving solution;
- extremely rapid tripping.

### Disadvantages:

- extremely low discrimination values;
- low service quality, since at least two circuit-breakers in series have to trip.

## Coordination between circuit-breaker and switch disconnecter

### The switch disconnecter

The switch disconnectors derive from the corresponding circuit-breakers, of which they keep the overall dimensions, the fixing systems and the possibility of mounting all the accessories provided for the basic versions. They are devices which can make, carry and break currents under normal service conditions of the circuit.

They can also be used as general circuit-breakers in sub-switchboards, as bus-ties, or to isolate installation parts, such as lines, busbars or groups of loads.

Once the contacts have opened, these switches guarantee isolation thanks to their contacts, which are at the suitable distance to prevent an arc from striking in compliance with the prescriptions of the standards regarding aptitude to isolation.

### Protection of switch disconnectors

Each switch disconnecter shall be protected by a coordinated device which safeguards it against overcurrents, usually a circuit-breaker able to limit the short-circuit current and the let-through energy values at levels acceptable for the switch-disconnector.

As regards overload protection, the rated current of the circuit-breaker shall be lower than or equal to the size of the disconnecter to be protected.

Regarding Isomax and Tmax series switch disconnectors the coordination tables show the circuit-breakers which can protect them against the indicated prospective short-circuit currents values.

Regarding Emax series switch disconnectors it is necessary to verify that the short-circuit current value at the installation point is lower than the short-time withstand current  $I_{CW}$  of the disconnecter, and that the peak value is lower than the making current value ( $I_{CM}$ ).

## 4 Protection coordination

### 4.2 Discrimination tables

The tables below give the selectivity values of short-circuit currents (in kA) between pre-selected combinations of circuit-breakers, for voltages from 380 to 415 V, according annex A of IEC 60947-2. The tables cover the possible combinations of ABB SACE Emax air circuit-breakers series, ABB SACE Isomax and Tmax moulded-case circuit-breakers series and the series of ABB modular circuit-breakers. The values are obtained following particular rules which, if not respected, may give selectivity values which in some cases may be much lower than those given. Some of these guidelines are generally valid and are indicated below; others refer exclusively to particular types of circuit-breakers and will be subject to notes below the relevant table.

### General rules:

- the function I of electronic releases of upstream breakers must be excluded (I3 in OFF);
- the magnetic trip of thermomagnetic (TM) or magnetic only (MA-MF) breakers positioned upstream must be  $\geq 10 \cdot I_n$  and set to the maximum threshold;
- it is fundamentally important to verify that the settings adopted by the user for the electronic and thermomagnetic releases of breakers positioned either upstream or downstream result in time-current curves properly spaced.

### Notes for the correct reading of the coordination tables:

The limit value of selectivity is obtained considering the lower among the given value, the breaking capacity of the CB on the supply side and the breaking capacity of the CB on the load side.

The letter T indicates total selectivity for the given combination, the corresponding value in kA is obtained considering the lower of the downstream and upstream circuit-breakers' breaking capacities (Icu).

The following tables show the breaking capacities at 415Vac for SACE Emax, Isomax and Tmax circuit-breakers.

Tmax @ 415V ac	
Version	Icu [kA]
B	16
C	25
N	36
S	50
H	70
L (for T2)	85
L (for T4-T5-T7)	120
L (for T6)	100
V (for T7)	150
V	200

Isomax @ 415V ac	
Version	Icu [kA]
S	50
H	65
L	100

Emax @ 415V ac	
Version	Icu [kA]
B	42
N	65*
S	75**
H	100
L	130***
V	150****

- \* For Emax E1 version N Icu=50kA
- \*\* For Emax E2 version S Icu=85kA
- \*\*\* For Emax X1 version L Icu=150kA
- \*\*\*\* For Emax E3 version V Icu=130kA

### Keys

For MCCB (Moulded-case circuit-breaker) ACB (Air circuit-breaker) TM = thermomagnetic release - TMD (Tmax) - TMA (Tmax) - T adjustable M adjustable (Isomax) M = magnetic only release - MF (Tmax) - MA (Tmax) EL = electronic release	For MCB (Miniature circuit-breaker): B = characteristic trip (I3=3...5In) C = characteristic trip (I3=5...10In) D = characteristic trip (I3=10...20In) K = characteristic trip (I3=8...14In) Z = characteristic trip (I3=2...3In)
---	--

### 4 Protection coordination

**Example:**

From the selectivity table on page 265 it can be seen that breakers E2N1250 and T5H400, correctly set, are selective up to 55kA (higher than the short-circuit current at the busbar).

From the selectivity table on page 258 it can be seen that, between T5H400 and T1N160 In125, the total selectivity is granted; as already specified on page 241 this means selectivity up to the breaking capacity of T1N and therefore up to 36 kA (higher than the short-circuit current at the busbar).

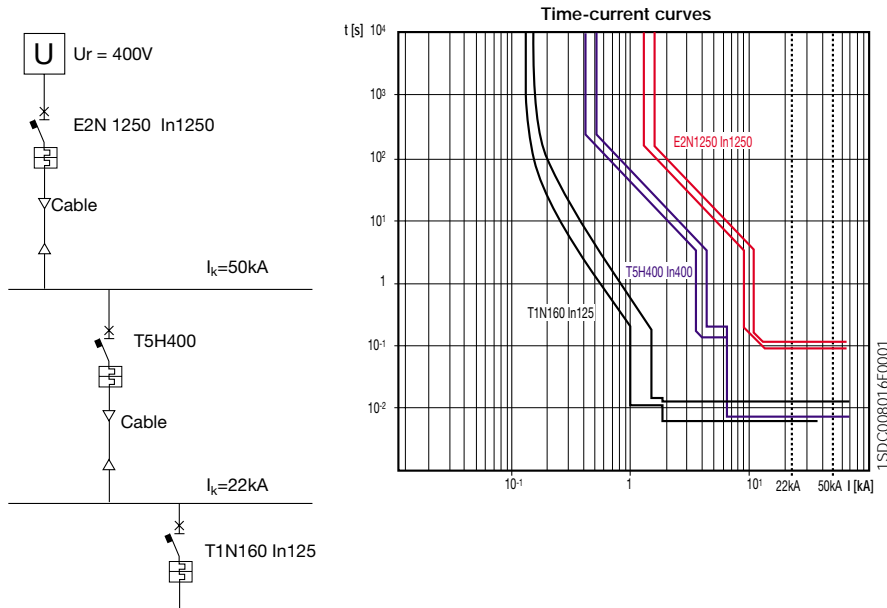

From the curves it is evident that between breakers E2N1250 and T5H400 time discrimination exists, while between breakers T5H400 and T1N160 there is energy discrimination.

### 4 Protection coordination

**Discrimination tables MCB-MCB**

**MCB - S2.. B @ 415V**

		Supply s.							
		S290		S500					
Char.	Icu [kA]	D		D					
		15		50					
		80	100	32	40	50	63		
Load s.	6	-	-	-	-	-	-		
	10	-	-	-	-	-	-		
	15	-	-	-	-	-	-		
	25	-	-	-	-	-	-		
	In [A]	≤2							
		3							
		4							
		6	10.5	T	1.5	2	3	5.5	
		8	10.5	T	1.5	2	3	5.5	
		10	5	8	1	1.5	2	3	
		13	4.5	7		1.5	2	3	
		16	4.5	7			2	3	
	20	3.5	5				2.5		
	25	3.5	5						
	32		4.5						
	40								
	50								
	63								

**MCB - S2.. C @ 415V**

		Supply s.							
		S290		S500					
Char.	Icu [kA]	D		D					
		15		50					
		80	100	32	40	50	63		
Load s.	6	-	-	-	-	-	-		
	10	-	-	-	-	-	-		
	15	-	-	-	-	-	-		
	25	-	-	-	-	-	-		
	In [A]	≤2	T	T	T	T	T		
		3	T	T	3	6	T		
		4	T	T	2	3	6		
		6	10.5	T	1.5	2	3	5.5	
		8	10.5	T	1.5	2	3	5.5	
		10	5	8	1	1.5	2	3	
		13	4.5	7		1.5	2	3	
		16	4.5	7			2	3	
	20	3.5	5				2.5		
	25	3.5	5						
	32		4.5						
	40								
	50								
	63								

### 4 Protection coordination

Discrimination tables MCB-MCB

MCB - S2.. D @ 415V

Char.		Supply s.									
		S290					S500				
		D					D				
Icu [kA]					In [A]	15		50			
	6	10	15	25		80	100	32	40	50	63
-	S200	S200M	S200P	≤2	T	T	T	T	T	T	T
-	S200	S200M	S200P	3	T	T	3	6	T	T	
-	S200	S200M	S200P	4	T	T	2	3	6	T	
-	S200	S200M	S200P	6	10.5	T	1.5	2	3	5.5	
-	S200	S200M	S200P	8	10.5	T	1.5	2	3	5.5	
-	S200	S200M	S200P	10	5	8	1	1.5	2	3	
-	S200	-	S200P	13	3	5			1.5	2	
-	S200	S200M	S200P	16	3	5				2	
-	S200	S200M	S200P	20	3	5					
-	S200	S200M	S200P	25		4					
-	S200	S200M-S200P	-	32							
-	S200	S200M-S200P	-	40							
-	S200	S200M-S200P	-	50							
-	S200	S200M-S200P	-	63							

MCB - S2.. K @ 415V

Char.		Supply s.									
		S290					S500				
		D					D				
Icu [kA]					In [A]	15		50			
	6	10	15	25		80	100	32	40	50	63
-	S200	S200M	S200P	≤2	T	T	T	T	T	T	T
-	S200	S200M	S200P	3	T	T	3	6	T	T	
-	S200	S200M	S200P	4	T	T	2	3	6	T	
-	S200	S200M	S200P	6	10.5	T	1.5	2	3	5.5	
-	S200	S200M	S200P	8	10.5	T	1.5	2	3	5.5	
-	S200	S200M	S200P	10	5	8		1.5	2	3	
-	-	-	S200P	13	3	5			1.5	2	
-	S200	S200M	S200P	16	3	5				2	
-	S200	S200M	S200P	20	3	5					
-	S200	S200M	S200P	25		4					
-	S200	S200M-S200P	-	32							
-	S200	S200M-S200P	-	40							
-	S200	S200M-S200P	-	50							
-	S200	S200M-S200P	-	63							

### 4 Protection coordination

MCB - S2.. Z @ 415V

Char.		Supply s.									
		S290					S500				
		D					D				
Icu [kA]					In [A]	15		50			
	6	10	15	25		80	100	32	40	50	63
-	S200	-	S200P	≤2	T	T	T	T	T	T	T
-	S200	-	S200P	3	T	T	3	6	T	T	
-	S200	-	S200P	4	T	T	2	3	6	T	
-	S200	-	S200P	6	10.5	T	1.5	2	3	5.5	
-	S200	-	S200P	8	10.5	T	1.5	2	3	5.5	
-	S200	-	S200P	10	5	8	1	1.5	2	3	
-	S200	-	S200P	13	4.5	7	1	1.5	2	3	
-	S200	-	S200P	16	4.5	7	1	1.5	2	3	
-	S200	-	S200P	20	3.5	5		1.5	2	2.5	
-	S200	-	S200P	25	3.5	5			2	2.5	
-	S200	S200P	-	32	3	4.5				2	
-	S200	S200P	-	40	3	4.5					
-	S200	S200P	-	50		3					
-	S200	S200P	-	63							

1SDC008005F0201

### 4 Protection coordination

### 4 Protection coordination

Discrimination tables MCB/MCCB - S500

MCB/MCCB - S500 @ 415V

Load s.	Char.	Icu [kA]	Version	B, C, N, S, H, L, V																B, C, N, S, H, L, V															
			Release	TM																EL															
			Supply s.	S290 D	T2	T1-T2				T1-T2-T3				T3				T4						T2					T4-T5						
In [A]	80	100	12.5	16	20	25	32	40	50	63	80	100	125	160	200	250	20	25	32	50	80	100	125	160	200+	250	10	25	63	100	160	100+	630		
S500	B, C	50	6	6	10	4.5	5.5	5.5	5.5	5.5	5.5	5.5	10.5	15	20	25	36	36	36	7.5	7.5 <sup>(4)</sup>	7.5	7.5	16	T	T	T	T			36	36	36	36	T
			10	6	10			4.5 <sup>(1)</sup>	4.5	4.5	4.5	4.5	8	10	20	25	36	36	36	6.5	6.5 <sup>(4)</sup>	6.5	6.5	11	T	T	T	T			36	36	36	36	T
			13	6	10			4.5 <sup>(1)</sup>		4.5	4.5	4.5	7.5	10	15	25	36	36	36	6.5	5 <sup>(4)</sup>	6.5	6.5	11	T	T	T	T			36	36	36	36	T
			16	6	10					4.5 <sup>(1)</sup>	4.5	4.5	7.5	10	15	25	36	36	36		5 <sup>(4)</sup>	6.5	6.5	11	T	T	T	T			36	36	36	36	T
			20	6	7.5					4.5 <sup>(1)</sup>	4.5	7.5	10	15	25	36	36	36		4 <sup>(4)</sup>	6.5	6.5	11	T	T	T	T			36	36	36	36	T	
			25	4.5	6						4.5 <sup>(1)</sup>	6	10	15	20	36	36	36			6.5	11	T	T	T	T			36	36	36	36	36	T	
			32		6							4.5 <sup>(1)</sup>	7.5	10	20	36	36	36			6.5	8	T	T	T	T			36	36	36	36	36	T	
			40										5 <sup>(1)</sup>	10	20	36	36	36				5 <sup>(4)</sup>	6.5	T	T	T	T				36	36	36	36	T
	50										5 <sup>(1)</sup>	7.5 <sup>(2)</sup>	15	36	36	36				5 <sup>(4)</sup>	7.5	T	T	T	T				36	36	36	36	T		
	63											5 <sup>(2)</sup>	6 <sup>(3)</sup>	36	36	36						5 <sup>(4)</sup>	7	T	T					36	36	36	36	T	
	D	50	6	6	10	4.5	5.5	5.5	5.5	5.5	5.5	10.5	15	20	25	36	36	36	7.5	7.5 <sup>(4)</sup>	7.5	7.5	16	T	T	T	T			36	36	36	36	T	
			10	6	10			4.5 <sup>(1)</sup>	4.5	4.5	4.5	4.5	8	10	20	25	36	36	36	6.5	6.5 <sup>(4)</sup>	6.5	6.5	11	T	T	T	T			36	36	36	36	T
			13	6	10			4.5 <sup>(1)</sup>		4.5	4.5	4.5	7.5	10	15	25	36	36	36		5 <sup>(4)</sup>		6.5	11	T	T	T	T			36	36	36	36	T
			16	6	10					4.5 <sup>(1)</sup>	4.5	4.5	7.5	10	15	25	36	36	36			6.5	11	T	T	T	T			36	36	36	36	T	
			20	6	7.5					4.5 <sup>(1)</sup>	4.5	7.5	10	15	25	36	36	36			6.5 <sup>(4)</sup>	11	T	T	T	T			36	36	36	36	T		
			25	4.5	6						4.5 <sup>(1)</sup>	6	10	15	20	36	36	36			6.5 <sup>(4)</sup>	11	T	T	T	T			36	36	36	36	36	T	
			32		6							4.5 <sup>(1)</sup>	7.5	10	20	36	36	36				8	T	T	T	T			36	36	36	36	36	T	
			40										5 <sup>(1)</sup>	10	20	36	36	36				6.5 <sup>(4)</sup>	T <sup>(4)</sup>	T	T	T	T				36	36	36	36	T
	50										5 <sup>(1)</sup>	7.5 <sup>(2)</sup>	15	36	36	36					7.5 <sup>(4)</sup>	T <sup>(4)</sup>	T	T	T				36	36	36	36	T		
	63											5 <sup>(2)</sup>	6 <sup>(3)</sup>	36	36	36						7 <sup>(4)</sup>	T <sup>(4)</sup>	T					36	36	36	36	T		
	K	50	≤5.8	T	T	36	36	36	36	36	36	36	36	36	36	36	36	36	40	40 <sup>(4)</sup>	40	40	40	T	T	T	T	50	50	50	50	50	T		
			5.3...8	10	T	4.5 <sup>(1)</sup>	5.5	5.5	5.5	5.5	5.5	10.5	36	36	36	50	T	T	6	6 <sup>(4)</sup>	6	6	40	T	T	T	T			50	50	50	50	T	
			7.3...11	7.5	T		4.5 <sup>(1)</sup>	4.5	4.5	4.5	4.5	8	36	36	36	50	T	T		5 <sup>(4)</sup>	5	5	40	T	T	T	T			50	50	50	50	T	
		30	10...15	4.5	10			4.5 <sup>(1)</sup>		4.5	4.5	4.5	7.5	10	15	T	T	T	T	5 <sup>(4)</sup>		5	12	T	T	T	T			T	T	T	T	T	
			14...20	4.5	6					4.5 <sup>(1)</sup>	4.5	4.5	7.5	10	15	T	T	T	T			5	12	T	T	T	T			T	T	T	T	T	
			18...26		4.5					4.5 <sup>(1)</sup>	4.5	7.5	10	15	T	T	T	T			5 <sup>(4)</sup>	12 <sup>(4)</sup>	T	T	T	T			T	T	T	T	T		
			23...32								4.5 <sup>(1)</sup>	6	10	15	20	T	T	T			5 <sup>(4)</sup>	12 <sup>(4)</sup>	T <sup>(4)</sup>	T	T	T			T	T	T	T	T		
			29...37								4.5 <sup>(1)</sup>	7.5	10	20	T	T	T			5 <sup>(4)</sup>	8 <sup>(4)</sup>	T <sup>(4)</sup>	T <sup>(4)</sup>	T	T			T	T	T	T	T			
34...41											5 <sup>(1)</sup>	10	20	T	T	T				6 <sup>(4)</sup>	T <sup>(4)</sup>	T <sup>(4)</sup>	T	T			T	T	T	T	T				
38...45											5 <sup>(1)</sup>	7.5 <sup>(2)</sup>	15	T	T	T				6 <sup>(4)</sup>	8 <sup>(4)</sup>	T <sup>(4)</sup>	T <sup>(4)</sup>	T			T	T	T	T	T				

<sup>(1)</sup> Value for the supply side magnetic only T2 circuit-breaker.  
<sup>(2)</sup> Value for the supply side magnetic only T2-T3 circuit-breaker.  
<sup>(3)</sup> Value for the supply side magnetic only T3 circuit-breaker.  
<sup>(4)</sup> Value for the supply side magnetic only T4 circuit-breaker.

1SDC008006F0201

### 4 Protection coordination

### 4 Protection coordination

Discrimination tables MCCB - S2..

MCCB - S2.. B @ 415V

Char.		Icu [kA]				Version	B, C, N, S, H, L																										B, C, N, S, H, L, V									
		Supply s.				Release	TM													TM													EL									
							T2	T1-T2				T1-T2-T3				T3		T4						T5	T2			T4			T5											
Load s.	B	6	10	15	25	In [A]	12.5	16	20	25	32	40	50	63	80	100	125	160	200	250	20	25	32	50	80	100	125	160	200	250	320+ 500	10	25	63	100	160	100	250	320+ 630			
		-	-	-	-	<2																																				
		-	-	-	-	3																																				
		-	-	-	-	4																																				
		-	S200	S200M	S200P	6	5.5 <sup>(1)</sup>	5.5	5.5	5.5	5.5	5.5	5.5	5.5	10.5	T	T	T	T	T	T	7.5	7.5 <sup>(4)</sup>	7.5	7.5	T	T	T	T	T	T	T	T	T	T	T	T	T	T	T	T	
		-	S200	S200M	S200P	8			5.5	5.5	5.5	5.5	5.5	10.5		T	T	T	T	T	T	7.5	7.5 <sup>(4)</sup>	7.5	7.5	T	T	T	T	T	T	T	T	T	T	T	T	T	T	T	T	
		-	S200	S200M	S200P	10			3 <sup>(1)</sup>	3	3	3	4.5	7.5		8.5	17	T	T	T	T	5	5 <sup>(4)</sup>	5	6.5	9	T	T	T	T	T	T	T	T	T	T	T	T	T	T	T	T
		-	S200	S200M	S200P	13			3 <sup>(1)</sup>		3	3	4.5	7.5		7.5	12	20	T	T	T		5 <sup>(4)</sup>	5	6.5	8	T	T	T	T	T	T	T	T	T	T	T	T	T	T	T	T
		-	S200	S200M	S200P	16					3 <sup>(1)</sup>	3	4.5	5		7.5	12	20	T	T	T		3 <sup>(4)</sup>	5	6.5	8	T	T	T	T	T	T	T	T	T	T	T	T	T	T	T	T
		-	S200	S200M	S200P	20					3 <sup>(1)</sup>		3	5		6	10	15	T	T	T				5	7.5	T	T	T	T	T	T	T	T	T	T	T	T	T	T	T	T
		-	S200	S200M	S200P	25							3 <sup>(1)</sup>	5		6	10	15	T	T	T				5	7.5	T	T	T	T	T	T	T	T	T	T	T	T	T	T	T	T
		-	S200	S200M-S200P	-	32							3 <sup>(1)</sup>			6	7.5	12	T	T	T				5 <sup>(4)</sup>	7.5	T	T	T	T	T	T	T	T	T	T	T	T	T	T	T	T
		-	S200	S200M-S200P	-	40										5.5 <sup>(1)</sup>	7.5	12	T	T	T					6.5	T	T	T	T	T	T	T	T	T	T	T	T	T	T	T	
		-	S200	S200M-S200P	-	50										3 <sup>(1)</sup>	5 <sup>(2)</sup>	7.5	10.5	T	T					5 <sup>(4)</sup>	T	T	T	T	T	T	T	T	T	T	T	T	T	T	T	
		-	S200	S200M-S200P	-	63											5 <sup>(2)</sup>	6 <sup>(3)</sup>	10.5	T	T						T <sup>(4)</sup>	T <sup>(4)</sup>	T	T	T	T	T	T	T	T	T	T	T	T	T	
		-	-	-	-	80																																				
-	-	-	-	100																																						
-	-	-	-	125																																						

<sup>(1)</sup> Value for the supply side magnetic only T2 circuit-breaker.  
<sup>(2)</sup> Value for the supply side magnetic only T2-T3 circuit-breaker.  
<sup>(3)</sup> Value for the supply side magnetic only T3 circuit-breaker.  
<sup>(4)</sup> Value for the supply side magnetic only T4 circuit-breaker.

1SDC008007F0201

## 4 Protection coordination

Discrimination tables MCCB - S2..

MCCB - S2.. C @ 415V

Char.	Icu [kA] 6    10    15    25				Version	B, C, N, S, H, L																															B, C, N, S, H, L, V									
					Release	TM															TM															EL										
					Supply s.	T2	T1-T2					T1-T2-T3					T3		T4					T5	T2					T4		T5														
					In [A]	12.5	16	20	25	32	40	50	63	80	100	125	160	200	250	20	25	32	50	80	100	125	160	200	250	320+ 500	10	25	63	100	160	100	250	320+ 630								
Load s. C	-	S200	S200M	S200P	≤2	T	T	T	T	T	T	T	T		T	T	T	T	T	T	T <sup>(4)</sup>	T	T	T	T	T	T	T	T	T	T	T	T	T	T	T	T	T	T							
	-	S200	S200M	S200P	3	T	T	T	T	T	T	T	T		T	T	T	T	T	T	T <sup>(4)</sup>	T	T	T	T	T	T	T	T	T	T	T	T	T	T	T	T	T	T	T						
	-	S200	S200M	S200P	4	T	T	T	T	T	T	T	T		T	T	T	T	T	T	T <sup>(4)</sup>	T	T	T	T	T	T	T	T	T	T	T	T	T	T	T	T	T	T	T	T					
	S200L	S200	S200M	S200P	6	5.5 <sup>(1)</sup>	5.5	5.5	5.5	5.5	5.5	5.5	10.5		T	T	T	T	T	7.5	7.5 <sup>(4)</sup>	7.5	7.5	T	T	T	T	T	T	T	T	T	T	T	T	T	T	T	T	T	T					
	S200L	S200	S200M	S200P	8			5.5	5.5	5.5	5.5	5.5	10.5		T	T	T	T	T	7.5	7.5 <sup>(4)</sup>	7.5	7.5	T	T	T	T	T	T	T	T	T	T	T	T	T	T	T	T	T	T					
	S200L	S200	S200M	S200P	10			3 <sup>(1)</sup>	3	3	3	4.5	7.5		8.5	17	T	T	T	T	5	5 <sup>(4)</sup>	5	6.5	9	T	T	T	T	T	T	T	T	T	T	T	T	T	T	T	T					
	S200L	S200	S200M	S200P	13			3 <sup>(1)</sup>		3	3	4.5	7.5		7.5	12	20	T	T	T		5 <sup>(4)</sup>	5	6.5	8	T	T	T	T	T	T	T	T	T	T	T	T	T	T	T						
	S200L	S200	S200M	S200P	16					3 <sup>(1)</sup>	3	4.5	5		7.5	12	20	T	T	T		3 <sup>(4)</sup>	5	6.5	8	T	T	T	T	T	T	T	T	T	T	T	T	T	T	T						
	S200L	S200	S200M	S200P	20					3 <sup>(1)</sup>		3	5		6	10	15	T	T	T				5	7.5	T	T	T	T	T	T	T	T	T	T	T	T	T	T	T						
	S200L	S200	S200M	S200P	25						3 <sup>(1)</sup>	5			6	10	15	T	T	T				5	7.5	T	T	T	T	T	T	T	T	T	T	T	T	T	T	T						
	S200L	S200	S200M-S200P	-	32						3 <sup>(1)</sup>				6	7.5	12	T	T	T				5 <sup>(4)</sup>	7.5	T	T	T	T	T	T	T	T	T	T	T	T	T	T	T						
	S200L	S200	S200M-S200P	-	40										5.5 <sup>(1)</sup>	7.5	12	T	T	T					6.5	T	T	T	T	T	T	T	T	T	T	T	T	T	T							
	-	S200	S200M-S200P	-	50										3 <sup>(1)</sup>	5 <sup>(2)</sup>	7.5	10.5	T	T					5 <sup>(4)</sup>	T	T	T	T	T	T	T	T	T	T	T	T	T	T							
	-	S200	S200M-S200P	-	63											5 <sup>(2)</sup>	6 <sup>(3)</sup>	10.5	T	T						T <sup>(4)</sup>	T <sup>(4)</sup>	T	T	T	T	T	T	T	T	T	T	T	T							
	-	-	S290	-	80												4 <sup>(3)</sup>	10	15									5	11	T	T				4	7 <sup>(9)</sup>	T	T								
	-	-	S290	-	100												4 <sup>(3)</sup>	7.5 <sup>(3)</sup>	15									5 <sup>(4)</sup>	8	T	T				4	12 <sup>(4)</sup>	T	T								
-	-	S290	-	125													7.5 <sup>(3)</sup>											8 <sup>(4)</sup>	12	T				4		T	T									

<sup>(1)</sup> Value for the supply side magnetic only T2 circuit-breaker.  
<sup>(2)</sup> Value for the supply side magnetic only T2-T3 circuit-breaker.  
<sup>(3)</sup> Value for the supply side magnetic only T3 circuit-breaker.  
<sup>(4)</sup> Value for the supply side magnetic only T4 circuit-breaker.  
<sup>(5)</sup> Value for the supply side T4 In160 circuit-breaker.

1SDC00808F0201







### 4 Protection coordination

### 4 Protection coordination

Discrimination tables MCCB - S2..

MCCB - S2.. Z @ 400V

Char.	Icu [kA]	Version												B, C, N, S, H, L												B, C, N, S, H, L, V																				
		Release												TM												EL																				
		Supply s.	T2	T1-T2				T1-T2-T3				T3		T4						T5	T2			T4			T5																			
6	10	15	25	In [A]	12.5	16	20	25	32	40	50	63	80	100	125	160	200	250	20	25	32	50	80	100	125	160	200	250	320+	500	10	25	63	100	160	100	250	320+	630							
Load s.	Z	-	S200	-	S200P	≤2	T	T	T	T	T	T	T	T	T	T	T	T	T	T <sup>(4)</sup>	T	T	T	T	T	T	T	T	T	T	T	T	T	T	T	T	T	T	T	T	T	T				
		-	S200	-	S200P	3	T	T	T	T	T	T	T	T	T	T	T	T	T	T	T <sup>(4)</sup>	T	T	T	T	T	T	T	T	T	T	T	T	T	T	T	T	T	T	T	T	T	T	T		
		-	S200	-	S200P	4	T	T	T	T	T	T	T	T	T	T	T	T	T	T	T <sup>(4)</sup>	T	T	T	T	T	T	T	T	T	T	T	T	T	T	T	T	T	T	T	T	T	T	T	T	T
		-	S200	-	S200P	6	5.5 <sup>(1)</sup>	5.5	5.5	5.5	5.5	5.5	5.5	10.5	T	T	T	T	T	T	T	7.5	7.5 <sup>(4)</sup>	7.5	7.5	T	T	T	T	T	T	T	T	T	T	T	T	T	T	T	T	T	T	T	T	
		-	S200	-	S200P	8			5.5	5.5	5.5	5.5	5.5	10.5	T	T	T	T	T	T	T	7.5	7.5 <sup>(4)</sup>	7.5	7.5	T	T	T	T	T	T	T	T	T	T	T	T	T	T	T	T	T	T	T	T	
		-	S200	-	S200P	10			3 <sup>(1)</sup>	3	3	3	4.5	8	8.5	17	T	T	T	T	T	5	5 <sup>(4)</sup>	5	6.5	9	T	T	T	T	T	T	T	T	T	T	T	T	T	T	T	T	T	T	T	
		-	-	-	S200P	13			3 <sup>(1)</sup>		3	3	4.5	7.5	7.5	12	20	T	T	T		5 <sup>(4)</sup>	5	6.5	8	T	T	T	T	T	T	T	T	T	T	T	T	T	T	T	T	T	T	T	T	
		-	S200	-	S200P	16					3 <sup>(1)</sup>	3	4.5	5	7.5	12	20	T	T	T		5 <sup>(4)</sup>	4.5	6.5	8	T	T	T	T	T	T	T	T	T	T	T	T	T	T	T	T	T	T	T	T	T
		-	S200	-	S200P	20					3 <sup>(1)</sup>	3	5	6	6	10	15	T	T	T				5	6.5	T	T	T	T	T	T	T	T	T	T	T	T	T	T	T	T	T	T	T	T	
		-	S200	-	S200P	25						3 <sup>(1)</sup>	5	6	6	10	15	T	T	T				5	6.5	T	T	T	T	T	T	T	T	T	T	T	T	T	T	T	T	T	T	T	T	
		-	S200	S200P	-	32						3 <sup>(1)</sup>		6	6	7.5	12	T	T	T				5 <sup>(4)</sup>	6.5	T	T	T	T	T	T	T	T	T	T	T	T	T	T	T	T	T	T	T	T	
		-	S200	S200P	-	40								5.5 <sup>(1)</sup>	5.5 <sup>(1)</sup>	7.5	12	T	T	T				5	6.5	T	T	T	T	T	T	T	T	T	T	T	T	T	T	T	T	T	T	T	T	
		-	S200	S200P	-	50								4 <sup>(1)</sup>	4 <sup>(1)</sup>	5 <sup>(2)</sup>	7.5	10.5	T	T				3.5 <sup>(4)</sup>	3.5 <sup>(4)</sup>	T	T	T	T	T	T	T	T	T	T	T	T	T	T	T	T	T	T	T	T	
		-	S200	S200P	-	63								5 <sup>(2)</sup>	5 <sup>(2)</sup>	6 <sup>(3)</sup>	10.5	T	T					7 <sup>(4)</sup>	7 <sup>(4)</sup>	T	T	T	T	T	T	T	T	T	T	T	T	T	T	T	T	T	T	T	T	
		-	-	-	-	80																																								
-	-	-	-	100																																										
-	-	-	-	125																																										

<sup>(1)</sup> Value for the supply side magnetic only T2 circuit-breaker.  
<sup>(2)</sup> Value for the supply side magnetic only T2-T3 circuit-breaker.  
<sup>(3)</sup> Value for the supply side magnetic only T3 circuit-breaker.  
<sup>(4)</sup> Value for the supply side magnetic only T4 circuit-breaker.

1SDC008011F0201







### 4 Protection coordination

Discrimination tables MCCB - MCCB

MCCB - T5 @ 415V

		Supply s.		T6					T7				S7		
Version				N,S,H,L					S,H,L,V*				S,H,L		
Release				TM,M		EL			EL				EL		
Load s.	N, S, H, L, V	I <sub>o</sub> [A]	I <sub>n</sub> [A]	630	800	630	800	1000	800	1000	1250	1600	1250	1600	
				320	30	30	30	30	30	30	30	T	T	T	T
T5	TM	400	320	30	30	30	30	30	T	T	T	T	T	T	T
		400	400		30		30	30	T	T	T	T	T	T	T
		630	500				30	30	T	T	T	T	T	T	T
	EL	400	320	30	30	30	30	30	T	T	T	T	T	T	T
		400	400	30	30	30	30	30	T	T	T	T	T	T	T
		630	630				30	30	T	T	T	T	T	T	T

\*Available only with I<sub>u</sub> ≤ 1250A  
 \*\*Values valid only with PR232/P, PR331/P and PR332/P electronic releases

MCCB - T6 @ 415V

		Supply s.		T7				S7		
Version				S,H,L,V*				S,H,L		
Release				EL				EL		
Load s.	N, S, H, L, V	I <sub>o</sub> [A]	I <sub>n</sub> [A]	800	1000	1250	1600	1250	1600	
				800	800			40	40	40
T6	TM	630	630			40	40		40	40
		800	800			40	40		40	40
		630	630	40	40	40	40	40	40	40
	EL	800	800	40	40	40	40	40	40	40
		800	800	40	40	40	40	40	40	40
		1000	1000			40	40		40	40

\*Available only with I<sub>u</sub> ≤ 1250A, maximum selectivity values is 15kA  
 \*\*Values valid only with PR232/P, PR331/P and PR332/P electronic releases

### 4 Protection coordination

Discrimination tables ACB - MCCB

ACB - MCCB @ 415V

		Supply s.		X1			E1		E2				E3				E4			E6				
Version				B	N	L	B	N	B	N	S	L*	N	S	H	V	L*	S	H	V	H	V		
Release				EL			EL		EL				EL				EL			EL				
Load s.	N, S, H, L, V	I <sub>o</sub> [A]	I <sub>n</sub> [A]	800	800	800	800	800	1600	1000	800	1250	2500	1000	800	800	2000	4000	3200	3200	4000	3200		
				1000	1000	1000	1000	1000	2000	1250	1000	1600	1250	1600	3200	1250	1000	1000	2500	4000	4000	4000	5000	4000
T1	TM	160		T	T	T	T	T	T	T	T	T	T	T	T	T	T	T	T	T	T	T	T	
		160		T	T	T	T	T	T	T	T	T	T	T	T	T	T	T	T	T	T	T	T	T
		160		T	T	T	T	T	T	T	T	T	T	T	T	T	T	T	T	T	T	T	T	T
T2	TM,EL	160		T	T	T	T	T	T	T	T	T	T	T	T	T	T	T	T	T	T	T	T	
		160		T	T	T	T	T	T	T	55	65	T	T	T	T	T	T	T	T	T	T	T	T
		160		T	T	T	T	T	T	T	55	65	T	T	T	75	T	T	T	T	T	T	T	T
T3	TM	250		T	T	T	T	T	T	T	T	T	T	T	T	T	T	T	T	T	T	T	T	
		250		T	T	T	T	T	T	T	T	T	T	T	T	T	T	T	T	T	T	T	T	T
		250		T	T	T	T	T	T	T	T	T	T	T	T	T	T	T	T	T	T	T	T	T
T4	TM,EL	250		T	T	T	T	T	T	T	T	T	T	T	T	T	T	T	T	T	T	T	T	
		320		T	T	T	T	T	T	T	T	T	T	T	T	T	T	T	T	T	T	T	T	T
		250		T	T	T	T	T	T	T	55	65	T	T	T	T	T	T	T	T	T	T	T	T
		320		T	T	T	T	T	T	T	55	65	100	T	T	75	85	100	T	T	100	T	100	T
T5	TM,EL	400		T	T	T	T	T	T	T	T	T	T	T	T	T	T	T	T	T	T	T	T	
		630		T	T	T	T	T	T	T	T	T	T	T	T	T	T	T	T	T	T	T	T	
		400		T	T	T	T	T	T	T	55	65	T	T	T	T	T	T	T	T	T	T	T	
		630		T	T	T	T	T	T	T	55	65	100	T	T	75	85	100	T	T	100	T	100	
T6	TM,EL	630		T	T	15	T	T	T	T	T	T	T	T	T	T	T	T	T	T	T	T	T	
		800		T	T	15	T	T	T	T	T	T	T	T	T	T	T	T	T	T	T	T	T	
		1000		T	T	15	T	T	T	T	55	65	T	T	T	T	T	T	T	T	T	T	T	
		1000		T	T	15	T	T	T	T	55	65	T	T	T	75	85	T	T	T	T	T	T	
T7	EL	800					T	T	T	T	T	T	T	T	T	T	T	T	T	T	T	T		
		1000					T	T	T	T	T	T	T	T	T	T	T	T	T	T	T	T		
		1250					T	T	T	55	T	T	T	T	T	T	T	T	T	T	T	T		
		1600					T	T	T	55	65	T	T	T	75	85	T	T	T	T	T	T		
S7	EL	1250					T	T	T	T	T	T	T	T	T	T	T	T	T	T	T	T		
		1600					T	T	T	55	T	T	T	T	T	T	T	T	T	T	T			
		1600					T	T	T	55	65	T	T	T	75	85	T	T	T	T	T			

Table valid for Emax circuit-breaker only with PR121/P, PR122/P and PR123/P releases  
 \*Emax L circuit-breakers only with PR122/P and PR123/P releases  
 \*\*Available only with I<sub>u</sub> ≤ 1250A

## 4 Protection coordination

### 4.3 Back-up tables

The tables shown give the short-circuit current value (in kA) for which the back-up protection is verified for the chosen circuit-breaker combination, at voltages from 380 up to 415 V. These tables cover all the possible combinations between ABB SACE moulded-case circuit-breakers Isomax and Tmax and those between the above mentioned circuit-breakers and ABB MCBs.

#### Notes for a correct interpretation of the coordination tables:

Tmax @ 415V ac	
Version	Icu [kA]
B	16
C	25
N	36
S	50
H	70
L (for T2)	85
L (for T4-T5)	120
L (for T6)	100
V (for T7)	150
V	200

Isomax @ 415V ac	
Version	Icu [kA]
S	50
H	65
L	100

Emax @ 415V ac	
Version	Icu [kA]
B	42
N	65*
S	75**
H	100
L	130***
V	150****

- \* For Emax E1 version N Icu=50kA
- \*\* For Emax E2 version S Icu=85kA
- \*\*\* For Emax X1 version L Icu=150kA
- \*\*\*\* For Emax E3 version V Icu=130kA

#### Keys

For MCCB (Moulded-case circuit-breaker) ACB (Air circuit-breaker) TM = thermomagnetic release - TMD (Tmax) - TMA (Tmax) - T adjustable M adjustable (Isomax) M = magnetic only release - MF (Tmax) - MA (Tmax) EL = electronic release	For MCB (Miniature circuit-breaker): B = characteristic trip (I3=3...5In) C = characteristic trip (I3=5...10In) D = characteristic trip (I3=10...20In) K = characteristic trip (I3=8...14In) Z = characteristic trip (I3=2...3In)
---	--

## 4 Protection coordination

#### Example:

From the coordination table on page 269 the following conclusion is derived: the circuit-breakers type T5H and T1N are coordinated in back-up protection up to a value of 65 kA (higher than the short-circuit current measured at the installation point), although the maximum breaking capacity of T1N, at 415 V, is 36 kA.

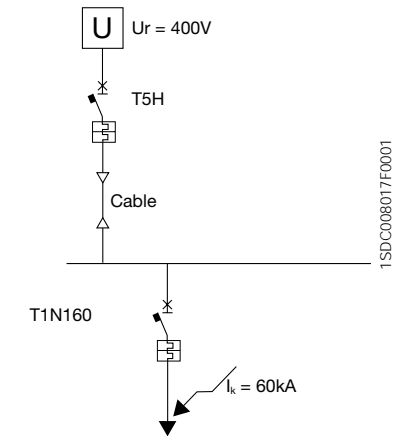

#### MCCB - MCB @ 240V

Load s.	Char.	Icu [kA]	In [A]	Supply s.							
				S 200L	S 200	S200M	S200P		S280	S290	S500
				C	B-C	B-C	B-C	B-C	C	B-C	
				10	20	25	40	40	20	25	100
				6.40	0.5..63	0.5..63	0.5..25	32..63	80, 100	80..125	6..63
S931 N	C	4.5	2..40	10	20	25	40	25	15	15	100
S941 N	B,C	6	2..40	10	20	25	40	25	15	15	100
S951 N	B,C	10	2..40	10	20	25	40	25	15	15	100
S971 N	B,C	10	2..40	10	20	25	40	25	15	15	100
S200L	C	10	6..40		20	25	40	25	15	15	100
S200	B,C,K,Z	20	0.5..63			25	40	25			100
S200M	B,C,D	25	0.5..63				40				100
S200P	B, C,	40	0.5..25								100
	D, K, Z	25	32..63								100
S280	B,C	20	80, 100								
S290	C,D	25	80..125								
S500	B,C,D		6..63								



### 4 Protection coordination

**MCB - MCB @ 415V**

Load s.	Char.	Icu [kA]	Supply s.		S200L		S200		S200M		S200P		S280	S290	S500
			Version	C	B-C	B-C	B-C	B-C	B-C	B-C	C	B-C			
			In [A]	6..40	0.5..63	0.5..63	0.5..25	32..63	80, 100	80..125	6..63				
S200L	C	6	6..40	10	15	25	15			6	15	50			
S200	B,C,K,Z	10	0.5..63			15	25	15				15	50		
S200M	B,C,D	15	0.5..63					25					50		
S200P	B, C,	25	0.5..25											50	
	D, K, Z	15	32..63												
S280	B,C	6	80, 100												
S290	C,D	15	80..125												
S500	B,C,D	50	6..63												

**MCCB - MCB @ 415V**

Load s.	Char.	In [A]	Supply s.		T1	T1	T1	T2	T3	T4	T2	T3	T4	T2	T4	T4										
			Version	B	C	N			S			H	L	L	V											
			Icu [kA]	16	25	36			50			70	85	120	200											
S200L	C	6..10	6	16	25	30	36	36	35	40	40	40	40	40	40	40										
		13..40															16	16	16	16	16	16	16	16	16	16
S200	B, C, K, Z	0.5..10	10	16	25	30	36	36	35	40	40	40	40	40	40	40										
		13..63															16	16	16	16	16	16	16	16	16	16
S200M	B, C, D	0.5..10	15	16	25	30	36	36	50	40	40	70	85	40	40	40										
		13..63															25	25	25	25	25	25	25	25	25	25
S200P	B, C, D, K, Z	0.5..10	25	16	25	30	36	36	50	40	40	70	85	40	40	40										
		13..25															30	30	30	30	30	30	30	30	30	30
		32..63															16	25	30	36	25	36	50	25	40	60
S280	B, C	80, 100	6	16	16	16	36	16	30	36	16	30	36	30	36	30	30									
S290	C, D	80,125	15	16	25	30	36	30	30	50	30	30	70	30	85	30	30									
S500	B, C, D	6..63	50										70	70	85	120	200									

TSDC008035F0201

### 4 Protection coordination

**MCCB - MCCB @ 415V**

Load side	Version	Icu [kA]	Supply s.		T1	T1	T2	T3	T4	T5	T6	T7	S7	T2	T4	T5	T6	T7	S7	T2	T4	T5	T6	T7	S7	T4	T5									
			Version	C	N						S						H						L	L	L	L	L	L	L	L	L	L	L	L		
			Icu [kA]	16	36						50						70						65	85	120	100*	200									
T1	B	16	25	36	36	36	36	30	30	30	50	50	36	36	36	36				70	40	40	40		85	50	50	50	50	85	85	70	50	50	130	100
T1	C	25									50	50	40	40	50	50	50			70	65	65	65	50	50	85	85	85	70	50	50	200	100			
T1	N	36									50	50	50	50	50	50	50			70	65	65	65	50	50	85	100	100	70	50	50	200	120			
T2												50	50	50	50	50	50	50			70	65	65	65	50	50	85	100	100	85	85	85	200	120		
T3													50	50	50	50	50	50			70	65	65	65	50	50	85	100	100	100	50	50	200	120		
T4													50	50	50	50	50	50			70	65	65	65	50	50	85	100	100	65	65	65	200	120		
T5														50	50	50	50	50			70	65	65	65	50	50	85	100	100	85	65	65	120			
T6															50	40	40				70	70	70	65	85	100	100	85	85	85	200	130				
T2	S	50																		70	70	70	65	85	100	100	85	85	85	200	150					
T3																					70	70	70		100	100	100			200	150					
T4																					70	70	70	65	100	100	85	85	85	200	150					
T5																					70	70	70	65	100	85	85	85	85	150						
T6																					70	70	70	65	100	85	85	85	85	150						
T6																					70	70	70	65	100	85	85	85	85	150						
T2	H	70																																		
T4																																				
T5																																				
T6																																				
T2	L	85																																		
T4		120																																		
T5																																				

\*120 kA for T7

TSDC008036F0201

## 4 Protection coordination

### 4.4 Coordination tables between circuit-breakers and switch disconnectors

The tables shown give the values of the short-circuit current (in kA) for which back-up protection is verified by the pre-selected combination of circuit-breaker and switch disconnector, for voltages between 380 and 415 V. The tables cover the possible combinations of moulded-case circuit-breakers in the ABB SACE Isomax and Tmax series, with the switch disconnectors detailed above.

## 4 Protection coordination

### Notes for the correct reading of the coordination tables:

Tmax @ 415V ac	
Version	Icu [kA]
B	16
C	25
N	36
S	50
H	70
L (for T2)	85
L (for T4-T5)	120
L (for T6)	100
V (for T7)	150
V	200

Isomax @ 415V ac	
Version	Icu [kA]
S	50
H	65
L	100

415 V	SWITCH DISCONNECTOR													
	T1D 160	T3D 250	T4D 320	T5D 400	T5D 630	T6D 630	T6D 800	T6D 1000	T7D 1000	T7D 1250	T7D 1600	S7D 1000	S7D 1250	S7D 1600
T1B	← 16 →													
T1C	← 25 →													
T1N	← 36 →													
T2N	← 36 →													
T2S	← 50 →													
T2H	← 70 →													
T2L	← 85 →													
T3N	← 36 →													
T3S	← 50 →													
T4N	← 36* →	← 36 →												
T4S	← 50* →	← 50 →												
T4H	← 70* →	← 70 →												
T4L	← 120* →	← 120 →												
T4V	← 200* →	← 200 →												
T5N	← 36 →													
T5S	← 50 →													
T5H	← 70 →													
T5L	← 120 →													
T5V	← 200 →													
T6N	← 36 →													
T6S	← 50 →													
T6H	← 65 →													
T6L	← 100 →													
T7S	← 50 →													
T7H	← 70 →													
T7L	← 120 →													
T7V	← 150 →													
S7S	← 50 →													
S7H	← 65 →													
S7L	← 100 →													

\* for T4 250 or T4 320 only with I1 setting at 250 A.

## 4 Protection coordination

Example:

From the coordination table on page 270-271 it can be seen that circuit-breaker T2S160 is able to protect the switch disconnector T1D160 up to a short-circuit current of 50 kA (higher than the short-circuit current at the installation point). Overload protection is also verified, as the rated current of the breaker is not higher than the size of the disconnector.

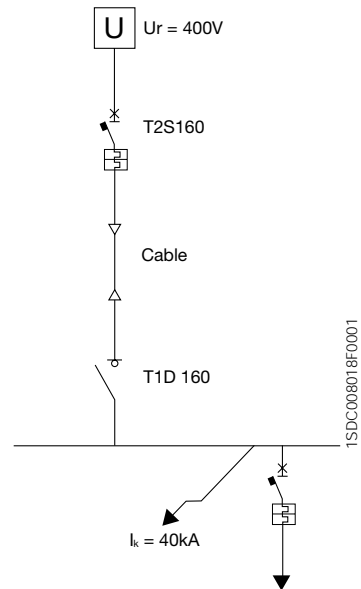

## 4 Protection coordination

Example:

For the correct selection of the components, the disconnector must be protected from overloads by a device with a rated current not greater than the size of the disconnector, while in short-circuit conditions it must be verified that:

$$I_{cw} \geq I_k$$

$$I_{cm} \geq I_p$$

Therefore, with regard to the electrical parameters of the single devices, Emax E2N1250/MS disconnector is selected, and a E2N1250 breaker.

That is:

$$I_{cw}(E2N /MS) = 55 \text{ kA} > 45 \text{ kA}$$

$$I_{cm} (E2N /MS) = 143 \text{ kA} > 100 \text{ kA.}$$

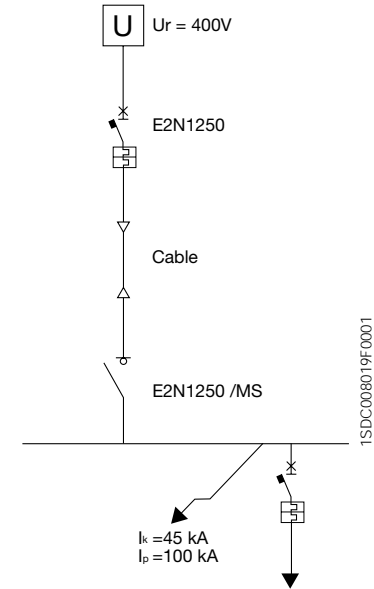

## 5 Special applications

### 5.1 Direct current networks

#### Main applications of direct current:

- Emergency supply or auxiliary services:  
the use of direct current is due to the need to employ a back-up energy source which allows the supply of essential services such as protection services, emergency lighting, alarm systems, hospital and industrial services, data-processing centres etc., using accumulator batteries, for example.
- Electrical traction:  
the advantages offered by the use of dc motors in terms of regulation and of single supply lines lead to the widespread use of direct current for railways, underground railways, trams, lifts and public transport in general.
- Particular industrial installations:  
there are some electrolytic process plants and applications which have a particular need for the use of electrical machinery.

Typical uses of circuit-breakers include the protection of cables, devices and the operation of motors.

#### Considerations for the interruption of direct current

Direct current presents larger problems than alternating current does in terms of the phenomena associated with the interruption of high currents. Alternating currents have a natural passage to zero of the current every half-cycle, which corresponds to a spontaneous extinguishing of the arc which is formed when the circuit is opened.

This characteristic does not exist in direct currents, and furthermore, in order to extinguish the arc, it is necessary that the current lowers to zero.

The extinguishing time of a direct current, all other conditions being equal, is proportional to the time constant of the circuit  $T = L/R$ .

It is necessary that the interruption takes place gradually, without a sudden switching off of the current which could cause large over-voltages. This can be carried out by extending and cooling the arc so as to insert an ever higher resistance into the circuit.

The energetic characteristics which develop in the circuit depend upon the voltage level of the plant and result in the installation of breakers according to connection diagrams in which the poles of the breaker are positioned in series to increase their performance under short-circuit conditions. The breaking capacity of the switching device becomes higher as the number of contacts which open the circuit increases and, therefore, when the arc voltage applied is larger.

This also means that when the supply voltage of the installation rises, so must the number of current switches and therefore the poles in series.

## 5 Special applications

#### Calculation of the short-circuit current of an accumulator battery

The short-circuit current at the terminals of an accumulator battery may be supplied by the battery manufacturer, or may be calculated using the following formula:

$$I_k = \frac{U_{Max}}{R_i}$$

where:

- $U_{Max}$  is the maximum flashover voltage (no-load voltage);
- $R_i$  is the internal resistance of the elements forming the battery.

The internal resistance is usually supplied by the manufacturer, but may be calculated from the discharge characteristics obtained through a test such as detailed by IEC 60896 – 1 or IEC 60896 – 2.

For example, a battery of 12.84 V and internal resistance of 0.005  $\Omega$  gives a short-circuit current at the terminals of 2568 A.

Under short-circuit conditions the current increases very rapidly in the initial moments, reaches a peak and then decreases with the discharge voltage of the battery. Naturally, this high value of the fault current causes intense heating inside the battery, due to the internal resistance, and may lead to explosion. Therefore it is very important to prevent and / or minimize short-circuit currents in direct currents systems supplied by accumulator batteries.

#### Criteria for the selection of circuit-breakers

For the correct selection of a circuit-breaker for the protection of a direct current network, the following factors must be considered:

1. the load current, according to which the size of the breaker and the setting for the thermo-magnetic over-current release can be determined;
2. the rated plant voltage, according to which the number of poles to be connected in series is determined, thus the breaking capacity of the device can also be increased;
3. the prospective short-circuit current at the point of installation of the breaker influencing the choice of the breaker;
4. the type of network, more specifically the type of earthing connection.

Note: in case of using of four pole circuit-breakers, the neutral must be at 100%

#### Direct current network types

Direct current networks may be carried out:

- with both polarities insulated from earth;
- with one polarity connected to earth;
- with median point connected to earth.

## 5 Special applications

### Network with both polarities insulated from earth

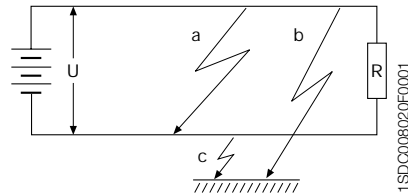

- Fault a: the fault, without negligible impedance, between the two polarities sets up a short-circuit current to which both polarities contribute to the full voltage, according to which the breaking capacity of the breaker must be selected.
- Fault b: the fault between the polarity and earth has no consequences from the point of view of the function of the installation.
- Fault c: again, this fault between the polarity and earth has no consequences from the point of view of the function of the installation.

In insulated networks it is necessary to install a device capable of signalling the presence of the first earth fault in order to eliminate it. In the worst conditions, when a second earth fault is verified, the breaker may have to interrupt the short-circuit current with the full voltage applied to a single polarity and therefore with a breaking capacity which may not be sufficient.

In networks with both polarities insulated from earth it is appropriate to divide the number of poles of the breaker necessary for interruption on each polarity (positive and negative) in such a way as to obtain separation of the circuit.

The diagrams to be used are as follows:

#### Diagram A

Three-pole breaker with one pole per polarity

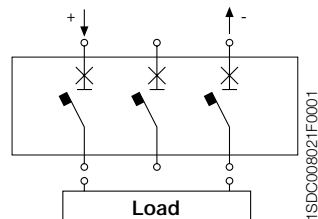

## 5 Special applications

#### Diagram B

Three-pole breaker with two poles in series for one polarity and one pole for the other polarity <sup>(1)</sup>

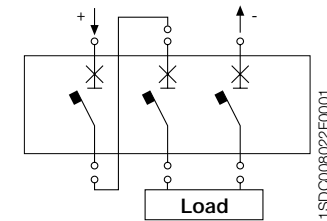

#### Diagram G

Four-pole breaker with two poles in parallel per polarity

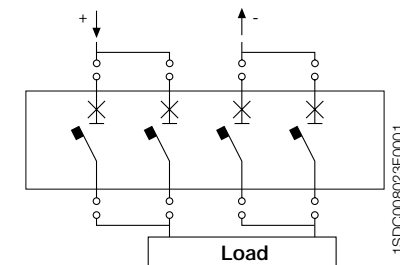

#### Diagram E

Four-pole breaker with three poles in series on one polarity and one pole on the remaining polarity <sup>(1)</sup>

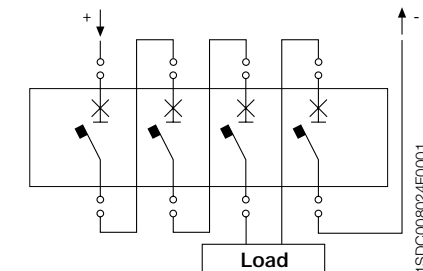

<sup>(1)</sup> It is not advisable to divide the poles of the breaker unequally as, in this type of network, a second earth fault may lead to the single pole working under fault conditions at full voltage. In these circumstances, it is essential to install a device capable of signalling the earth fault or the loss of insulation of one polarity.

## 5 Special applications

**Diagram F**

Four-pole breaker with two poles in series per polarity

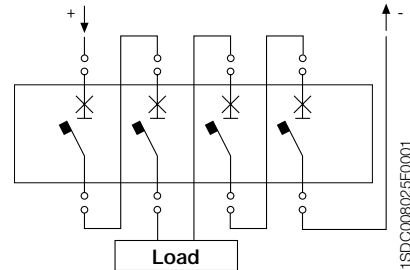

**Network with one polarity connected to earth**

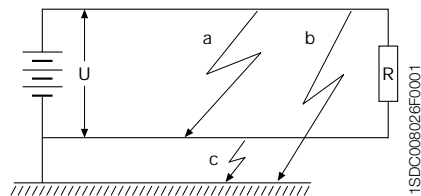

- Fault a: the fault between the two polarities sets up a short-circuit current to which both polarities contribute to the full voltage  $U$ , according to which the breaking capacity of the breaker is selected.
  - Fault b: the fault on the polarity not connected to earth sets up a current which involves the over-current protection according to the resistance of the ground.
  - Fault c: the fault between the polarity connected to earth and earth has no consequences from the point of view of the function of the installation.
- In a network with one polarity connected to earth, all the poles of the breaker necessary for protection must be connected in series on the non-earthed polarity. If isolation is required, it is necessary to provide another breaker pole on the earthed polarity.

## 5 Special applications

Diagrams to be used with circuit isolation are as follows:

**Diagram A**

Three-pole breaker with one pole per polarity

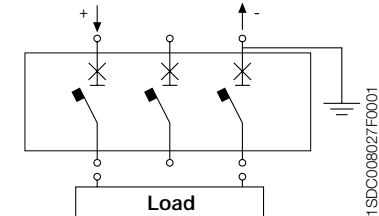

**Diagram B**

Three-pole breaker with two poles in series on the polarity not connected to earth, and one pole on the remaining polarity

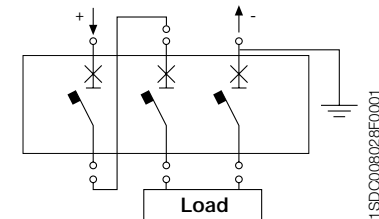

**Diagram G**

Four-pole breaker with two poles in parallel per polarity

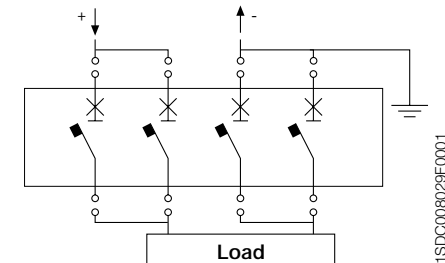

## 5 Special applications

### Diagram E

Four-pole breaker with three poles in series on the polarity not connected to earth, and one pole on the remaining polarity

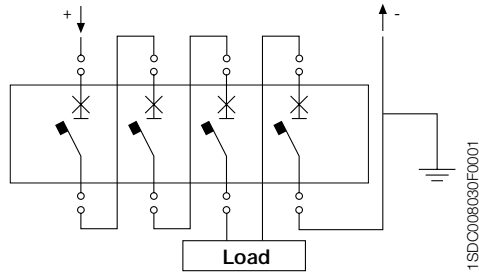

Diagrams to be used without circuit isolation are as follows:

### Diagram C

Three-pole breaker with three poles in series

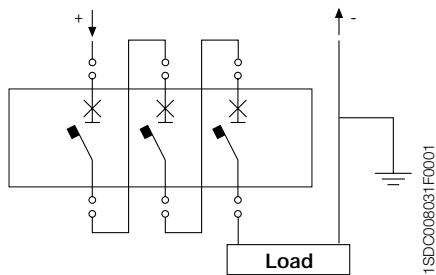

### Diagram H

Four-pole breaker with series of two poles in parallel

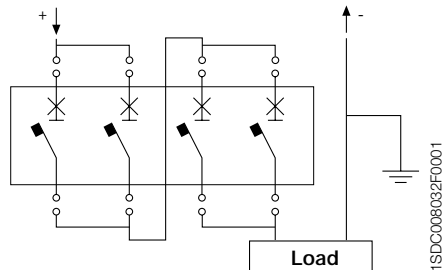

## 5 Special applications

### Diagram D

Four-pole breaker with four poles in series on the polarity not connected to earth

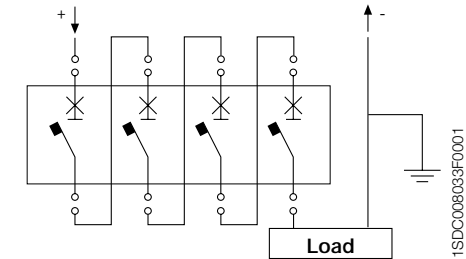

### Network with the median point connected to earth

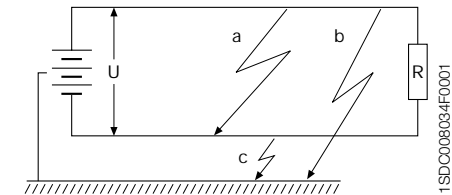

- Fault a: the fault between the two polarities sets up a short-circuit current to which both polarities contribute to the full voltage  $U$ , according to which the breaking capacity of the breaker is selected.
- Fault b: the fault between the polarity and earth sets up a short-circuit current less than that of a fault between the two polarities, as it is supplied by a voltage equal to  $0.5 U$ .
- Fault c: the fault in this case is analogous to the previous case, but concerns the negative polarity.

With network with the median point connected to earth the breaker must be inserted on both polarities.

Diagrams to be used are as follows:

### Diagram A

Three-pole breaker with one pole per polarity

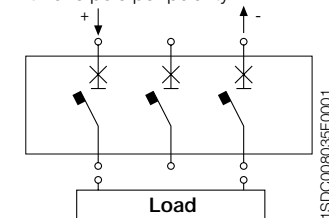

## 5 Special applications

### Diagram G

Four-pole breaker with two poles in parallel per polarity

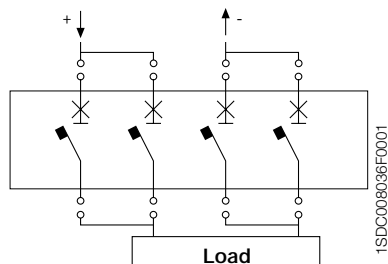

### Diagram F

Four-pole breaker with two poles in series per polarity

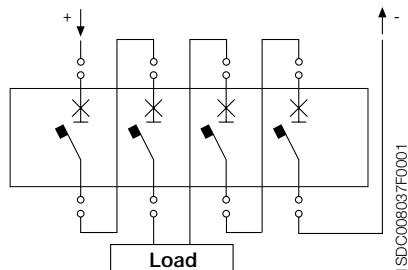

## Use of switching devices in direct current

### Parallel connection of breaker poles

According to the number of poles connected in parallel, the coefficients detailed in the following table must be applied:

**Table 1: Correction factor for poles connected in parallel**

number of poles in parallel	2	3	4 (neutral 100%)
reduction factor of dc carrying capacity	0.9	0.8	0.7
breaker current carrying capacity	1.8xIn	2.4xIn	2.8xIn

The connections which are external from the breaker terminals must be carried out by the user in such a way as to ensure that the connection is perfectly balanced.

## 5 Special applications

### Example:

Using a Tmax T6N800 In800 circuit-breaker with three poles in parallel, a coefficient equal to 0.8 must be applied, therefore the maximum carrying current will be  $0.8 \cdot 3 \cdot 800 = 1920$  A.

### Behaviour of thermal releases

As the functioning of these releases is based on thermal phenomena arising from the flowing of current, they can therefore be used with direct current, their trip characteristics remaining unaltered.

### Behaviour of magnetic releases

The values of the trip thresholds of ac magnetic releases, used for direct current, must be multiplied by the following coefficient ( $k_m$ ), according to the breaker and the connection diagram:

**Table 2:  $k_m$  coefficient**

Circuit-breaker	diagram A	diagram B	diagram C	diagram D	diagram E	diagram F	diagram G	diagram H
T1	1.3	1	1	-	-	-	-	-
T2	1.3	1.15	1.15	-	-	-	-	-
T3	1.3	1.15	1.15	-	-	-	-	-
T4	1.3	1.15	1.15	1	1	1	-	-
T5	1.1	1	1	0.9	0.9	0.9	-	-
T6	1.1	1	1	0.9	0.9	0.9	1.1	1

### Example

Data:

- Direct current network connected to earth;
- Rated voltage  $U_r = 250$  V;
- Short-circuit current  $I_k = 32$  kA
- Load current  $I_b = 230$  A

Using Table 3, it is possible to select the Tmax T3N250 In = 250 A three pole breaker, using the connection shown in diagram B (two poles in series for the polarity not connected to earth and one poles in series for the polarity connected to earth).

From Table 2 corresponding to diagram B, and with breaker Tmax T3, it results  $k_m=1.15$ ; therefore the nominal magnetic trip will occur at 2875 A (taking into account the tolerance, the trip will occur between 2300 A and 3450 A).



## 5 Special applications

The following table summarizes the breaking capacity of the various circuit-breakers available for direct current. The number of poles to be connected in series to guarantee the breaking capacity is given in brackets.

**Table 3: Breaking capacity in direct current according to the voltage**

Circuit-breaker	Rated current [A]	Breaking capacity [kA]			
		≤ 125 [V] <sup>1</sup>	250 [V]	500 [V]	750 [V]
<b>T1B160</b>	16 ÷ 160	16 (1P)	20 (3P) - 16 (2P)	16 (3P)	
<b>T1C160</b>	25 ÷ 160	25 (1P)	30 (3P) - 25 (2P)	25 (3P)	
<b>T1N160</b>	32 ÷ 160	36 (1P)	40 (3P) - 36 (2P)	36 (3P)	
<b>T2N160</b>	1.6 ÷ 160	36 (1P)	40 (3P) - 36 (2P)	36 (3P)	
<b>T2S160</b>	1.6 ÷ 160	50 (1P)	55 (3P) - 50 (2P)	50 (3P)	
<b>T2H160</b>	1.6 ÷ 160	70 (1P)	85 (3P) - 70 (2P)	70 (3P)	
<b>T2L160</b>	1.6 ÷ 160	85 (1P)	100 (3P) - 85 (2P)	85 (3P)	
<b>T3N250</b>	63 ÷ 250	36 (1P)	40 (3P) - 36 (2P)	36 (3P)	
<b>T3S250</b>	63 ÷ 250	50 (1P)	55 (3P) - 50 (2P)	50 (3P)	
<b>T4N250/320</b>	20 ÷ 250	36 (1P)	36 (2P)	25 (2P)	16 (3P)
<b>T4S250/320</b>	20 ÷ 250	50 (1P)	50 (2P)	36 (2P)	25 (3P)
<b>T4H250/320</b>	20 ÷ 250	70 (1P)	70 (2P)	50 (2P)	36 (3P)
<b>T4L250/320</b>	20 ÷ 250	100 (1P)	100 (2P)	70 (2P)	50 (3P)
<b>T4V250/320</b>	20 ÷ 250	100 (1P)	100 (2P)	100 (2P)	70 (3P)
<b>T5N400/630</b>	320 ÷ 500	36 (1P)	36 (2P)	25 (2P)	16 (3P)
<b>T5S400/630</b>	320 ÷ 500	50 (1P)	50 (2P)	36 (2P)	25 (3P)
<b>T5H400/630</b>	320 ÷ 500	70 (1P)	70 (2P)	50 (2P)	36 (3P)
<b>T5L400/630</b>	320 ÷ 500	100 (1P)	100 (2P)	70 (2P)	50 (3P)
<b>T5V400/630</b>	320 ÷ 500	100 (1P)	100 (2P)	100 (2P)	70 (3P)
<b>T6N630/800</b>	630-800	36 (1P)	36 (2P)	20 (2P)	16 (3P)
<b>T6S630/800</b>	630-800	50 (1P)	50 (2P)	35 (2P)	20 (3P)
<b>T6H630/800</b>	630-800	70 (1P)	70 (2P)	50 (2P)	36 (3P)
<b>T6L630/800</b>	630-800	100 (1P)	100 (2P)	65 (2P)	50 (3P)

<sup>1</sup> Minimum allowed voltage 24 Vdc.

## 5 Special applications

### 5.2 Networks at particular frequencies: 400 Hz and 16 2/3 Hz

Standard production breakers can be used with alternating currents with frequencies other than 50/60 Hz (the frequencies to which the rated performance of the device refer, with alternating current) as appropriate derating coefficients are applied.

#### 5.2.1 400 Hz networks

At high frequencies, performance is reclassified to take into account phenomena such as:

- the increase in the skin effect and the increase in the inductive reactance directly proportional to the frequency causes overheating of the conductors or the copper components in the breaker which normally carry current;
- the lengthening of the hysteresis loop and the reduction of the magnetic saturation value with the consequent variation of the forces associated with the magnetic field at a given current value.

In general these phenomena have consequences on the behaviour of both thermo-magnetic releases and the current interrupting parts of the circuit-breaker.

The following tables refer to circuit-breakers with thermomagnetic releases, with a breaking capacity lower than 36 kA. This value is usually more than sufficient for the protection of installations where such a frequency is used, normally characterized by rather low short-circuit currents.

As can be seen from the data shown, the tripping threshold of the thermal element ( $I_{th}$ ) decreases as the frequency increases because of the reduced conductivity of the materials and the increase of the associated thermal phenomena; in general, the derating of this performance is generally equal to 10%. Vice versa, the magnetic threshold ( $I_b$ ) increases with the increase in frequency; for this reason it is recommended practice to use a 5- $I_n$  version.

## 5 Special applications

Table 1: Tmax performance T1 16-63 A TMD

	I1 (400Hz)			I3			
	MIN	MED	MAX	I3 (50Hz)	$K_m$	I3 (400Hz)	
T1B 160							
T1C 160	In16	10	12	14	500	2	1000
T1N 160	In20	12	15	18	500	2	1000
	In25	16	19	22	500	2	1000
	In32	20	24.5	29	500	2	1000
	In40	25	30.5	36	500	2	1000
	In50	31	38	45	500	2	1000
	In63	39	48	57	630	2	1260

$K_m$  = Multiplier factor of I3 due to the induced magnetic fields

## 5 Special applications

Table 2: Tmax performance T1 80 A TMD

	I1 (400Hz)			I3			
	MIN	MED	MAX	I3 (50Hz)	$K_m$	I3 (400Hz)	
T1B 160							
T1C 160	In80	50	61	72	800	2	1600
T1N 160							

$K_m$  = Multiplier factor of I3 due to the induced magnetic fields

Trip curves  
thermomagnetic release

### T1 B/C/N 160

In 16 to 63 A  
TMD

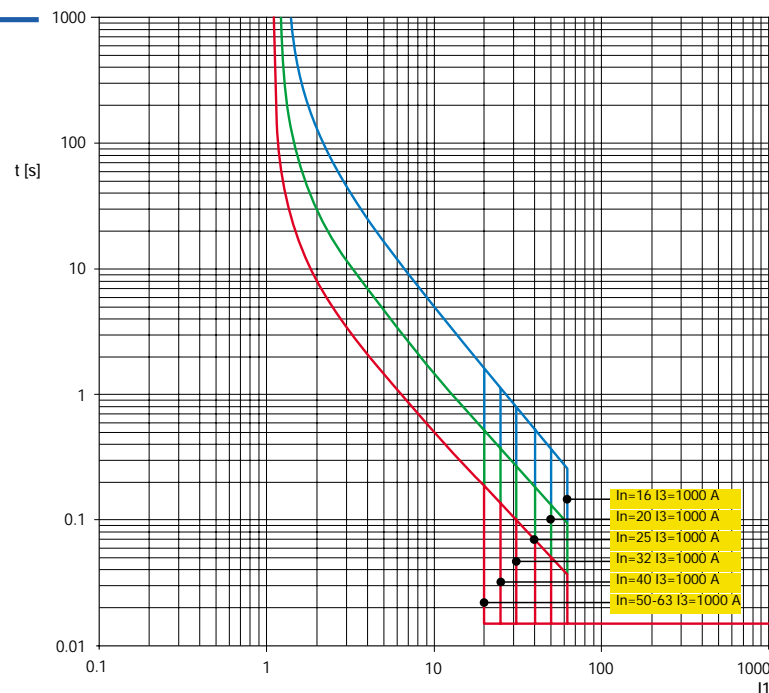

Trip curves  
thermomagnetic release

### T1 B/C/N 160

In 80 A  
TMD

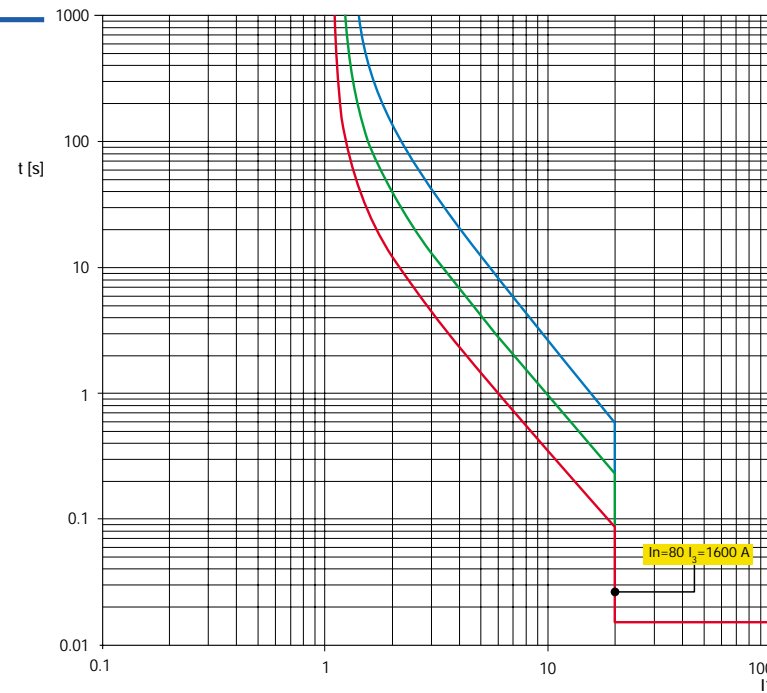

### 5 Special applications

Table 3: Tmax performance T2 1.6-80 A TMD

T2N 160	I1 (400Hz)			I3		
	MIN	MED	MAX	I3 (50Hz)	$K_m$	I3 (400Hz)
In1.6	1	1.2	1.4	16	1.7	27.2
In2	1.2	1.5	1.8	20	1.7	34
In2.5	1.5	1.9	2.2	25	1.7	42.5
In3.2	2	2.5	2.9	32	1.7	54.4
In4	2.5	3	3.6	40	1.7	68
In5	3	3.8	4.5	50	1.7	85
In6.3	4	4.8	5.7	63	1.7	107.1
In8	5	6.1	7.2	80	1.7	136
In10	6.3	7.6	9	100	1.7	170
In12.5	7.8	9.5	11.2	125	1.7	212.5
In16	10	12	14	500	1.7	850
In20	12	15	18	500	1.7	850
In25	16	19	22	500	1.7	850
In32	20	24.5	29	500	1.7	850
In40	25	30.5	36	500	1.7	850
In50	31	38	45	500	1.7	850
In63	39	48	57	630	1.7	1071
In80	50	61	72	800	1.7	1360

$K_m$  = Multiplier factor of I3 due to the induced magnetic fields

Trip curves thermomagnetic release

T2N 160  
In 1.6 to 80 A  
TMD

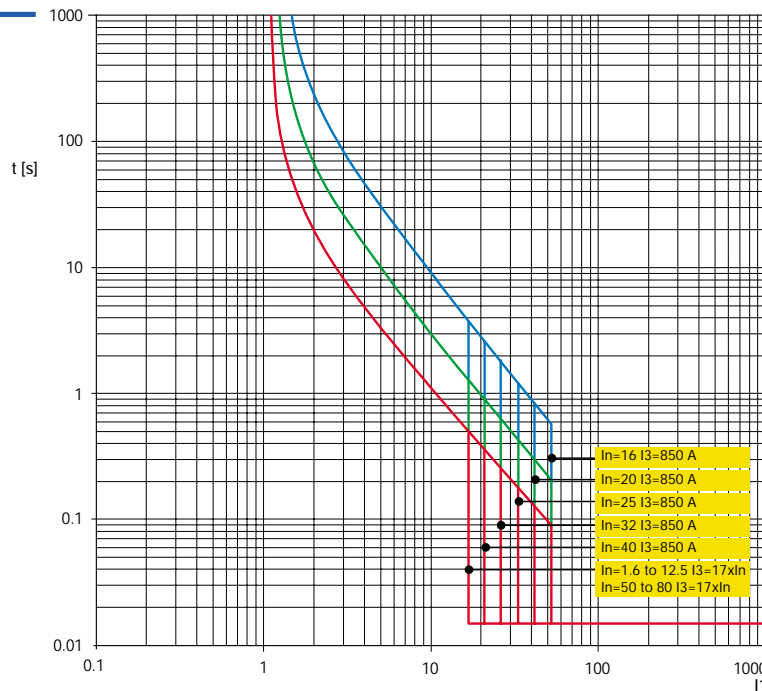

### 5 Special applications

Table 4: Tmax performance T2 16-160 A TMG

T2N 160	I1 (400Hz)			I3		
	MIN	MED	MAX	I3 (50Hz)	$K_m$	I3 (400Hz)
In16	10	12	14	160	1,7	272
In25	16	19	22	160	1,7	272
In40	25	30,5	36	200	1,7	340
In63	39	48	57	200	1,7	340
In80	50	61	72	240	1,7	408
In100	63	76,5	90	300	1,7	510
In125	79	96	113	375	1,7	637,5
In160	100	122	144	480	1,7	816

Trip curves thermomagnetic release

T2N 160  
In 16 to 160 A  
TMG

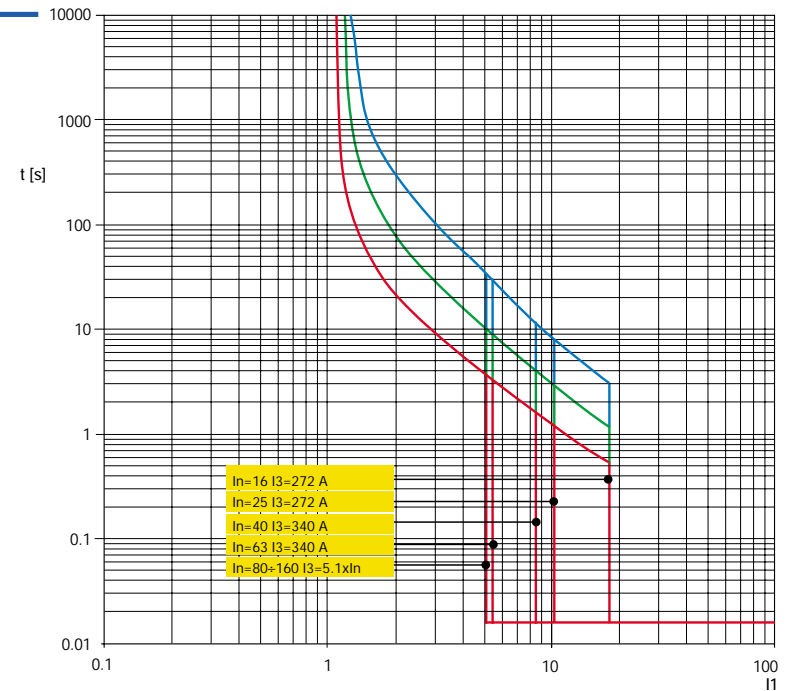

### 5 Special applications

Table 5: Tmax performance T3 63-250 A TMG

T3N 250	I1 (400Hz)			I3 (Low magnetic setting)		
	MIN	MED	MAX	I3 (50Hz)	K <sub>m</sub>	I3 (400Hz)
In63	39	48	57	400	1.7	680
In80	50	61	72	400	1.7	680
In100	63	76.5	90	400	1.7	680
In125	79	96	113	400	1.7	680
In160	100	122	144	480	1.7	816
In200	126	153	180	600	1.7	1020
In250	157	191	225	750	1.7	1275

K<sub>m</sub> = Multiplier factor of I3 due to the induced magnetic fields

Trip curves  
thermomagnetic release

#### T3N 250

In 63 to 250 A  
TMG

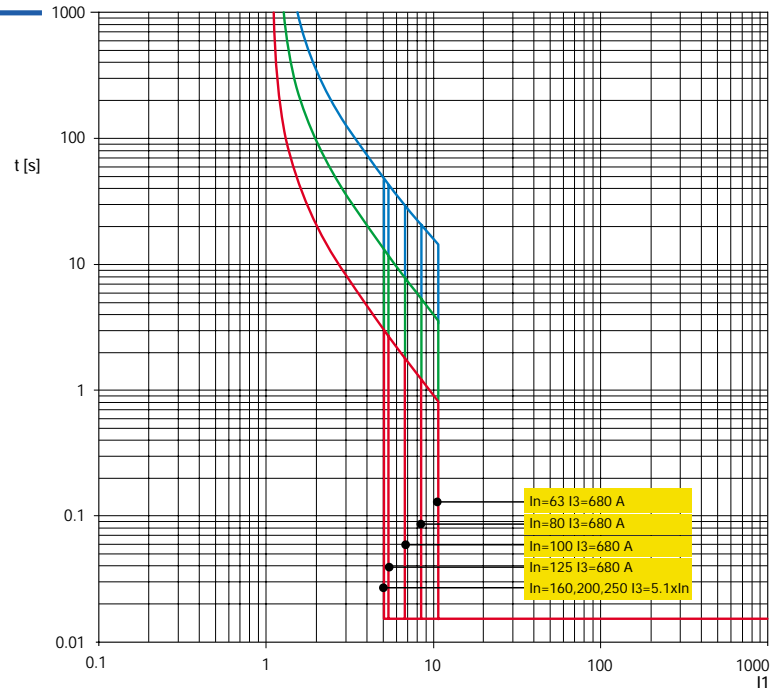

### 5 Special applications

Table 6: Tmax performance T3 63-125 A TMD

T3N 250	I1 (400Hz)			I3		
	MIN	MED	MAX	I3 (50Hz)	K <sub>m</sub>	I3 (400Hz)
In63	39	48	57	630	1.7	1071
In80	50	61	72	800	1.7	1360
In100	63	76.5	90	1000	1.7	1700
In125	79	96	113	1250	1.7	2125

K<sub>m</sub> = Multiplier factor of I3 due to the induced magnetic fields

Trip curves  
thermomagnetic release

#### T3N 250

In 63 to 125 A  
TMD

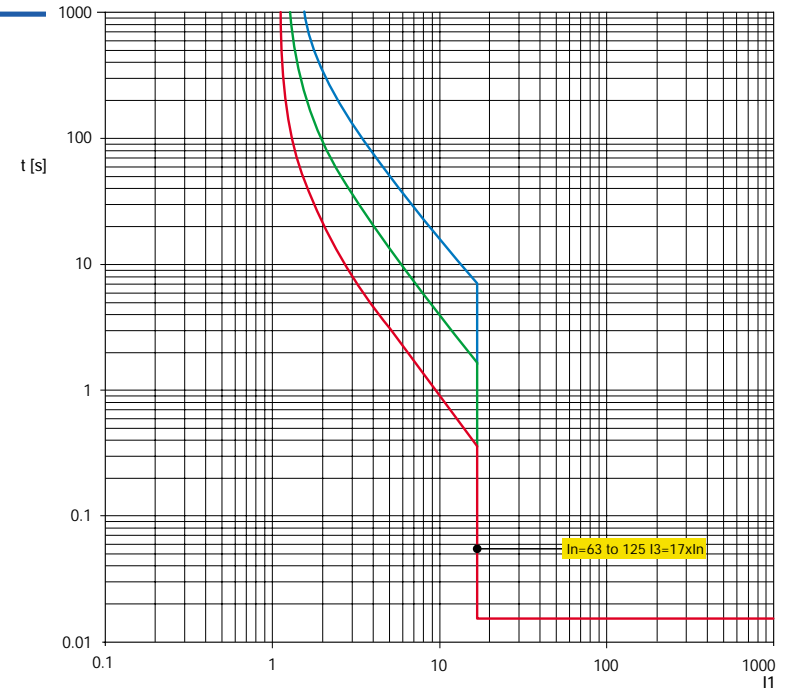

## 5 Special applications

Table 7: Tmax performance T4 20-50 A TMD

T4N 250	I1 (400Hz)			I3		
	MIN	MED	MAX	I3 (50Hz)	K <sub>m</sub>	I3 (400Hz)
In20	12	15	18	320	1.7	544
In32	20	24.5	29	320	1.7	544
In50	31	38	45	500	1.7	850

K<sub>m</sub> = Multiplier factor of I3 due to the induced magnetic fields

Trip curves  
thermomagnetic release

### T4N 250

In 20 to 50 A  
TMD

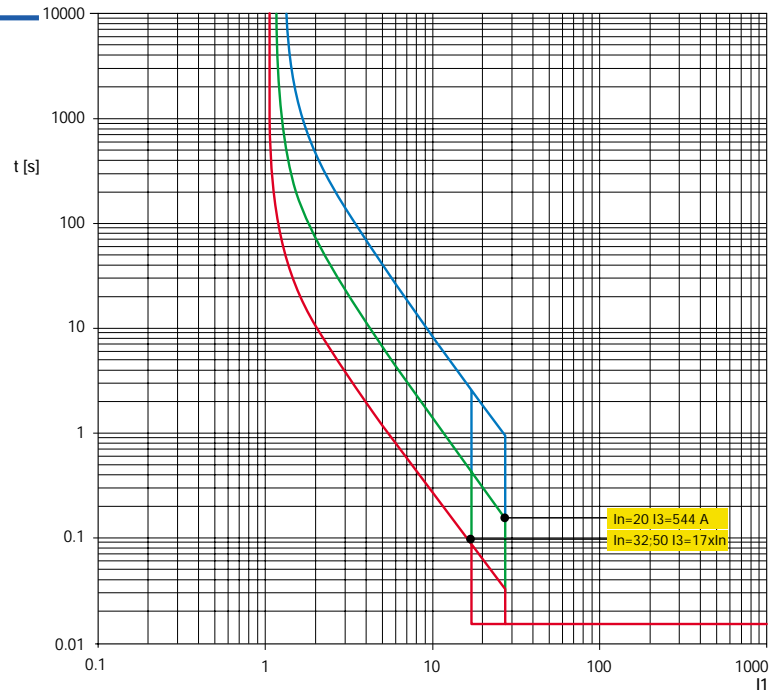

## 5 Special applications

Table 8: Tmax performance T4N 80-250 A TMA

T4N 250/320	I1 (400Hz)			I3 setting (MIN=5xIn)		
	MIN	MED	MAX	I3 @ 5xIn (50Hz)	K <sub>m</sub>	I3 @ 5xIn (400Hz)
In80	50	61	72	400	1.7	680
In100	63	76.5	90	500	1.7	850
In125	79	96	113	625	1.7	1060
In160	100	122	144	800	1.7	1360
In200	126	153	180	1000	1.7	1700
In250	157	191	225	1250	1.7	2125

K<sub>m</sub> = Multiplier factor of I3 due to the induced magnetic fields

Trip curves  
thermomagnetic release

### T4N 250/320

In 80 to 250 A  
TMA

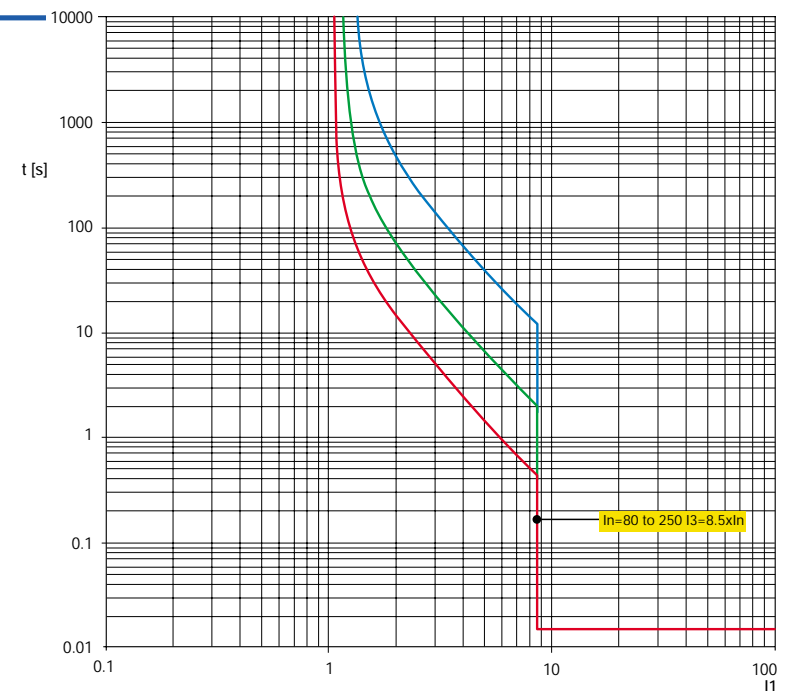

## 5 Special applications

Table 9: Tmax performance T5N 320-500 A TMA

T5N400/630	I1 (400Hz)			I3 setting (MIN=5xIn)		
	MIN	MED	MAX	I3 @ 5xIn(50Hz)	K <sub>m</sub>	I3 @ 5xIn (400)Hz
In320	201	244	288	1600	1.5	2400
In400	252	306	360	2000	1.5	3000
In500	315	382	450	2500	1.5	3750

K<sub>m</sub> = Multiplier factor of I3 due to the induced magnetic fields

Trip curves  
thermomagnetic release

### T5 N 400/630

In 320 to 500 A  
TMA

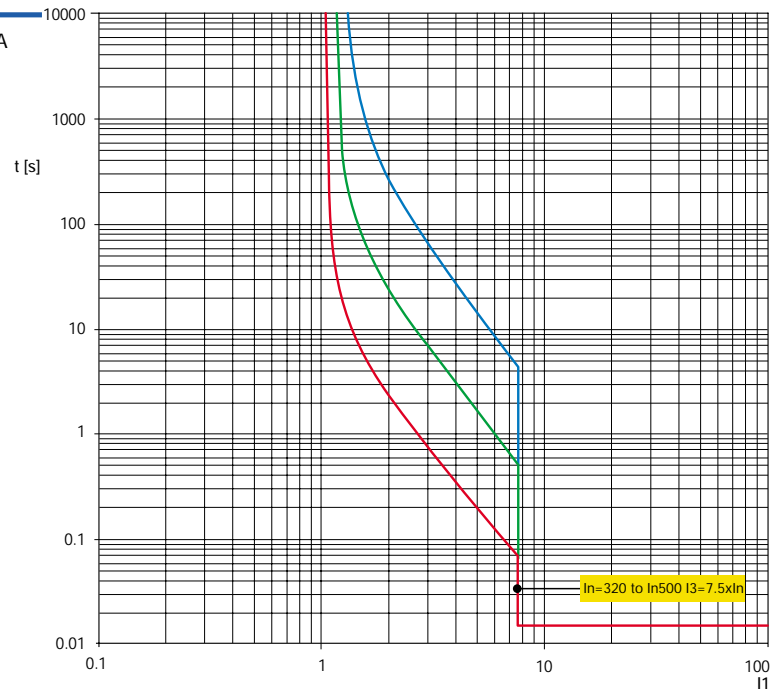

## 5 Special applications

Table 10: Tmax performance T5N 320-500 A TMG

T5N400/630	I1 (400Hz)			I3 setting (2.5...5xIn)		
	MIN	MED	MAX	I3 @ 2.5..5xIn (50Hz)	K <sub>m</sub>	I3 @ 2.5..5xIn (400Hz)
In320	201	244	288	800...1600	1.5	1200...2400
In400	252	306	360	1000...2000	1.5	1500...3000
In500	315	382	450	1250...2500	1.5	1875...3750

K<sub>m</sub> = Multiplier factor of I3 due to the induced magnetic fields

Trip curves  
thermomagnetic release

### T5N 400/630

In 320 to 500 A  
TMG

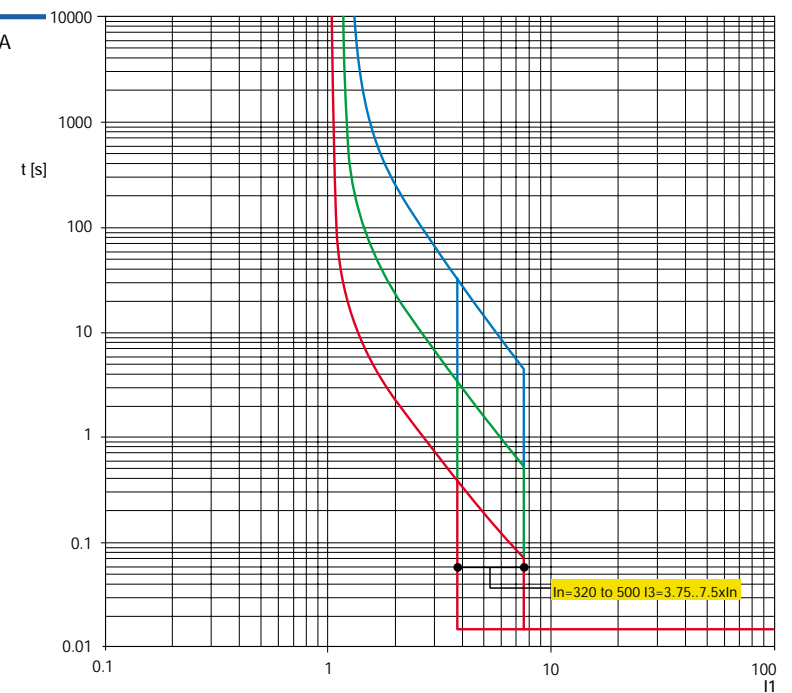

### 5 Special applications

Table 11: Tmax performance T6N 630 A TMA

T6N630	In630	I1 (400Hz)			I3 = 5·10In (set I3=5In)		
		MIN	MED	MAX	I3 (50Hz)	K <sub>m</sub>	I3 (400Hz)
		397	482	567	3150	1.5	4725

K<sub>m</sub> = Multiplier factor of I3 due to the induced magnetic fields

Trip curves  
thermomagnetic release

#### T6N 630

In 630 A  
TMA

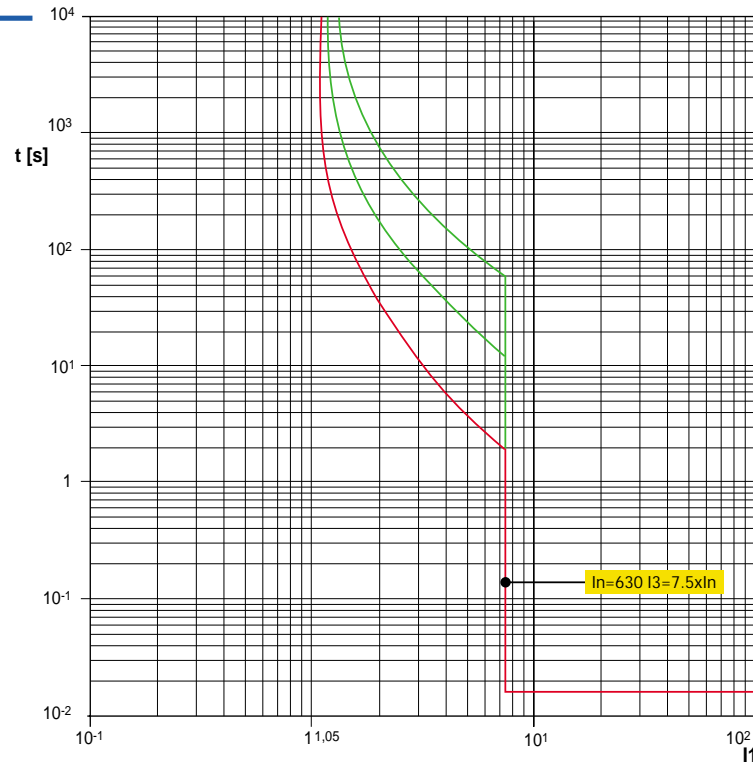

### 5 Special applications

Table 12: Tmax performance T6N 800 A TMA

T6N 800	In800	I1 (400Hz)			I3 = 5·10In (set I3=5In)		
		MIN	MED	MAX	I3 (50Hz)	K <sub>m</sub>	I3 (400Hz)
		504	602	720	4000	1.5	6000

K<sub>m</sub> = Multiplier factor of I3 due to the induced magnetic fields

Trip curves  
thermomagnetic release

#### T6N 800

In 800 A  
TMA

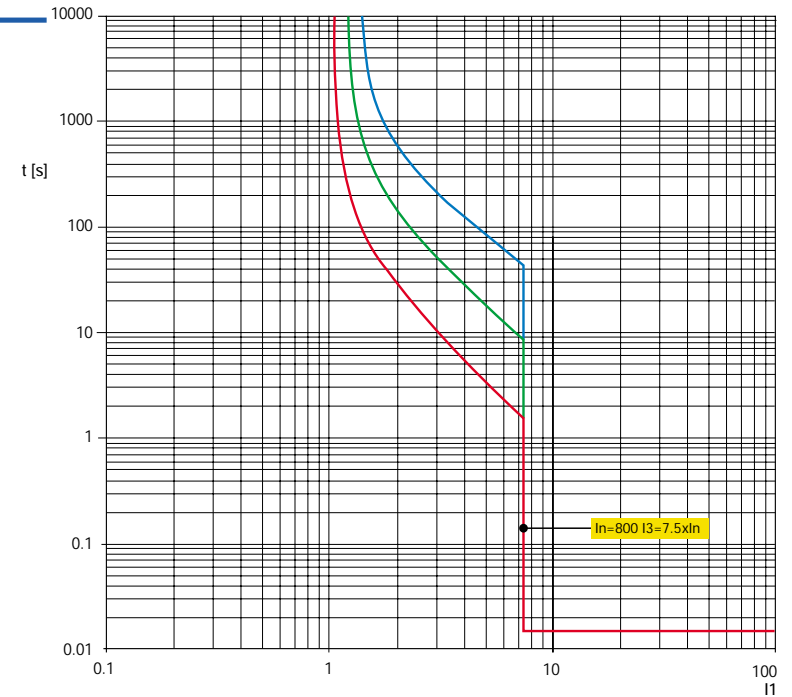

## 5 Special applications

### 5.2.2 16 2/3 Hz networks

Single phase distribution with a frequency of 16 2/3 Hz was developed for electrical traction systems as an alternative to three phase 50 Hz systems, and to direct current systems.

At low frequencies the thermal tripping threshold is not subject to any derating, while the magnetic threshold requires a correction coefficient  $k_m$ , as detailed in table 2.

The Isomax and Tmax series thermomagnetic moulded-case circuit-breakers are suitable for use with frequencies of 16 2/3 Hz; the electrical performance and the relevant connection diagrams are shown below.

Table 1: Breaking capacity [kA]

		250 V	500 V	750 V	1000 V (1)
	<b>In [A]</b>				
T1B160	16 + 160	16 (2P) 20 (3P)	16 (3P)	-	-
T1C160	25 + 160	25 (2P) 30 (3P)	25 (3P)	-	-
T1N160	32 + 160	36 (2P) 40 (3P)	36 (3P)	-	-
T2N160	1.6 + 160	36 (2P) 40 (3P)	36 (3P)	-	-
T2S160	1.6 + 160	50 (2P) 55 (3P)	50 (3P)	-	-
T2H160	1.6 + 160	70 (2P) 85 (3P)	70 (3P)	-	-
T2L160	1.6 + 160	85 (2P) 100 (3P)	85 (3P)	50 (4P) (2)	-
T3N250	63 + 250	36 (2P) 40 (3P)	36 (3P)	-	-
T3S250	63 + 250	50 (2P) 55 (3P)	50 (3P)	-	-
T4N250/320	20 + 250	36 (2P)	25 (2P)	16 (3P)	-
T4S250/320	20 + 250	50 (2P)	36 (2P)	25 (3P)	-
T4H250/320	20 + 250	70 (2P)	50 (2P)	36 (3P)	-
T4L250/320	20 + 250	100 (2P)	70 (2P)	50 (3P)	-
T4V250/320	20 + 250	150 (2P)	100 (2P)	70 (3P)	-
T4V250	32 + 250	-	-	-	40 (4P)
T5N400/630	320 + 500	36 (2P)	25 (2P)	16 (3P)	-
T5S400/630	320 + 500	50 (2P)	36 (2P)	25 (3P)	-
T5H400/630	320 + 500	70 (2P)	50 (2P)	36 (3P)	-
T5L400/630	320 + 500	100 (2P)	70 (2P)	50 (3P)	-
T5V400/630	320 + 500	150 (2P)	100 (2P)	70 (3P)	-
T5V400/630	400 + 500	-	-	-	40 (4P)
T6N630/800	630 + 800	36 (2P)	20 (2P)	16 (3P)	-
T6S630/800	630 + 800	50 (2P)	35 (2P)	20 (3P)	-
T6H630/800	630 + 800	70 (2P)	50 (2P)	36 (3P)	-
T6L630/800	630 + 800	100 (2P)	70 (2P)	50 (3P)	40 (4P)

(1) 1000V version circuit-breakers in dc, with neutral at 100%.

(2) Circuit-breakers with neutral at 100%.

## 5 Special applications

Table 2:  $k_m$  factor

	Diagram A	Diagram B-C	Diagram D-E-F
T1	1	1	-
T2	0.9	0.9	0.9
T3	0.9	0.9	-
T4	0.9	0.9	0.9
T5	0.9	0.9	0.9
T6	0.9	0.9	0.9

Table 3: Possible connections according to the voltage, the type of distribution and the type of fault

	Neutral not grounded	Neutral grounded*	
		L-N fault	L-E fault
250 V 2 poles in series	A1	A2	B2
250 V 3 poles in series**	B1	B2, C	B3
500 V 2 poles in series	A1	A2, B2	B2, C
500 V 3 poles in series**	B1	B2, C	C
750 V 3 poles in series	B1	B2, C	C
750 V 4 poles in series***	E-F	E1, D	E1
1000 V 4 poles in series	E-F	E1, C3	E1

\* In the case of the only possible faults being L-N or L-E (E=Earth) with non-significant impedance, use the diagrams shown. If both faults are possible, use the diagrams valid for L-E fault.

\*\* T1, T2, T3 only ,

\*\*\* T2 only

### Connection diagrams

#### Diagram A1

Configuration with two poles in series (without neutral connected to earth)

- Interruption for phase to neutral fault: 2 poles in series
- Interruption for phase to earth fault: not considered

(The installation method must be such as to make the probability of a second earth fault negligible)

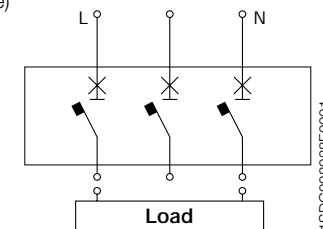

#### Diagram A2

Configuration with two poles in series (with neutral connected to earth)

- Interruption for phase to neutral fault: 2 poles in series
- Interruption for phase to earth fault: single pole (same capacity as two poles in series, but limited to 125V)

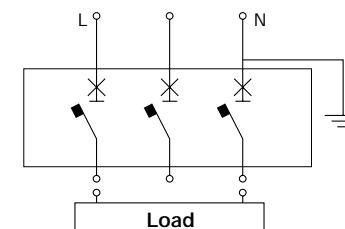



## 5 Special applications

**Diagram B1**

Configuration with three poles in series (without neutral connected to earth)

- Interruption for phase to neutral fault: 3 poles in series
- Interruption for phase to earth fault: not considered

(The installation method must be such as to make the probability of a second earth fault negligible)

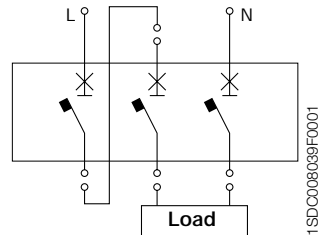

**Diagram B2**

Configuration with three poles in series (with neutral connected to earth and interrupted)

- Interruption for phase to neutral fault: 3 poles in series
- Interruption for phase to earth fault: 2 poles in series

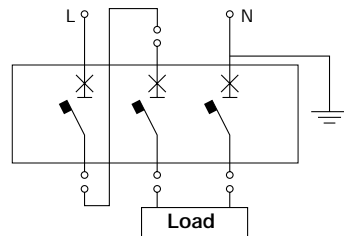

**Diagram C**

Configuration with three poles in series (with neutral connected to earth but not interrupted)

- Interruption for phase to neutral fault: 3 poles in series
- Interruption for phase to earth fault: 3 poles in series

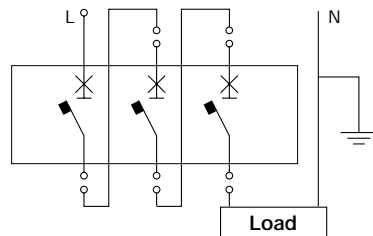

## 5 Special applications

**Diagram E-F**

Configuration with four poles in series (without neutral connected to earth)

- Interruption for phase to neutral fault: 4 poles in series
- Interruption for phase to earth fault: not considered

(The installation method must be such as to make the probability of a second earth fault negligible)

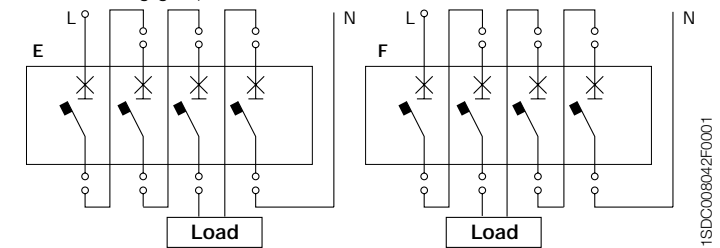

**Diagram D**

Configuration with four poles in series, on one polarity (with neutral connected to earth and not interrupted)

- Interruption for phase to neutral fault: 4 poles in series
- Interruption for phase to earth fault: 4 poles in series

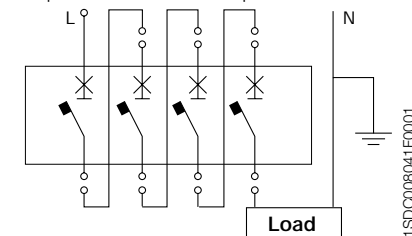

**Diagram E1**

Interruption with four poles in series (with neutral connected to earth and interrupted)

- Interruption for phase to neutral fault: 4 poles in series
- Interruption for phase to earth fault: 3 poles in series

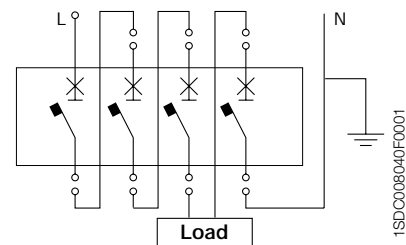

## 5 Special applications

### Example:

Network data:

Rated voltage 250 V

Rated frequency 16 2/3 Hz

Load current 120 A

Phase to neutral short-circuit current 45 kA

Neutral connected to earth

Assuming that the probability of a phase to earth fault is negligible, Table 3 shows that connections A2, B2 or B3 may be used.

Therefore it is possible to choose a Tmax T2S160 In125 circuit-breaker, which with the connection according to diagram A2 (two poles in series) has a breaking capacity of 50 kA, while according to diagrams B2 or B3 (three poles in series) the breaking capacity is 55 kA (Table 1). To determine the magnetic trip, see factor  $k_m$  in Table 2. The magnetic threshold will be:

$$I_3 = 1250 \cdot 0.9 = 1125 \text{ A}$$

whichever diagram is used.

If it is possible to have an earth fault with non significant impedance, the diagrams to be considered (Table 3) are only B2 or B3. In particular, in diagram B2 it can be seen that only 2 poles are working in series, the breaking capacity will be 50 kA (Table 1), while with diagram B3, with 3 poles working in series, the breaking capacity is 55 kA.

### 5.3 1000 Vdc and 1000 Vac networks

The Tmax, SACE Isomax and Emax /E 1000 V and 1150 V circuit-breakers are particularly suitable for use in installations in mines, petrochemical plants and services connected to electrical traction (tunnel lighting).

#### 5.3.1 1000 V dc networks

### 1000 Vdc Moulded case circuit-breakers

#### General Characteristics

The range of Tmax and SACE Isomax S moulded-case circuit-breakers for use in installations with rated voltage up to 1000 Vdc comply with international standard IEC 60947-2. The range is fitted with adjustable thermo-magnetic releases and is suitable for all installation requirements and has a range of available settings from 32 A to 800 A. The four-pole version circuit-breakers allow high performance levels to be reached thanks to the series connection of the poles.

The circuit breakers in the Tmax and SACE Isomax S 1000 V range maintain the same dimensions and fixing points as standard circuit breakers.

These circuit-breakers can also be fitted with the relevant range of standard accessories, with the exception of residual current releases for Tmax and mechanical interlocks for SACE Isomax.

In particular it is possible to use conversion kits for removable and withdrawable moving parts and various terminal kits.

## 5 Special applications

1000 V dc Moulded-case circuit-breakers	T4	T5	T6
Rated uninterrupted current, $I_u$ [A]	250	400/630	630/800
Poles Nr.	4	4	4
Rated operational voltage, $U_e$ [V -]	1000	1000	1000
Rated impulse withstand voltage, $U_{imp}$ [kV]	8	8	8
Rated insulation voltage, $U_i$ [V]	1000	1000	1000
Test voltage at industrial frequency for 1 min. [V]	3500	3500	3500
Rated ultimate short-circuit breaking capacity, $I_{cu}$ (4 poles in series) [kA]	V	V	L
Rated short-time withstand current for 1 s, $I_{cw}$ [kA]	-	5 (400A)	7.6 (630A) - 10 (800A)
Utilisation category (EN 60947-2)	A	B (400A)-A (630A)	B
Isolation behaviour	■	■	■
IEC 60947-2, EN 60947-2	■	■	■
Thermomagnetic releases TMD	■	-	-
Thermomagnetic releases TMA	■	up to 500 A	■
Versions	F	F	F
Terminals Fixed	FC Cu	FC Cu	F - FC CuAl - R
Mechanical life [No. operations / operations per hours]	20000/240	20000/120	20000/120
Basic dimensions, fixed L [mm]	140	184	280
D [mm]	103.5	103.5	103.5
H [mm]	205	205	268

TERMINAL CAPTION

F = Front

EF = Front extended

ES = Front extended spread

FC Cu = Front for copper cables

FC CuAl = Front for CuAl cables

R = Rear orientated

HR = Rear in horizontal flat bar

VR = Rear in vertical flat bar

MC = Multicable

### Connection diagrams

Possible connection diagrams with reference to the type of distribution system in which they can be used follow.

#### Networks insulated from earth

The following diagrams can be used (the polarity may be inverted).

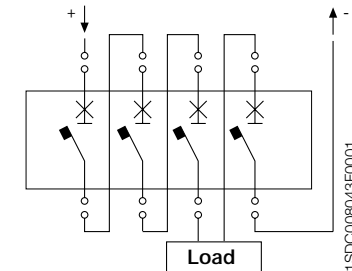

A) 3+1 poles in series (1000 Vdc)

## 5 Special applications

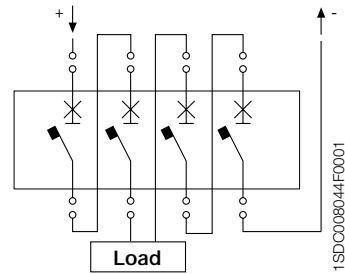

B) 2+2 poles in series (1000 Vdc)

It is assumed that the risk of a double earth fault in which the first fault is downstream of the breaker on one polarity and the second is upstream of the same switching device on the opposite polarity is null.

In this condition the fault current, which can reach high values, effects only some of the 4 poles necessary to ensure the breaking capacity.

It is possible to prevent the possibility of a double earth fault by installing a device which signals the loss of insulation and identifies the position of the first earth fault, allowing it to be eliminated quickly.

### Networks with one polarity connected to earth

As the polarity connected to earth does not have to be interrupted (in the example it is assumed that the polarity connected to earth is negative, although the following is also valid with the polarity inverted), the diagram which shows the connection of 4 poles in series on the polarity not connected to earth may be used.

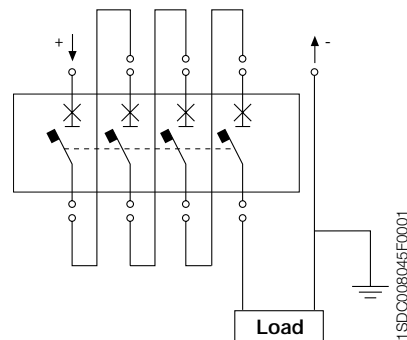

C) 4 poles in series (1000 Vdc)

## 5 Special applications

### Networks with median point of the supply source connected to earth

In the presence of an earth fault of positive or negative polarity, the poles involved in the fault work at  $U/2$  (500 V); the following diagram must be used:

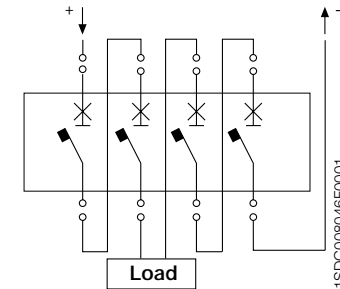

D) 2+2 poles in series (1000 Vdc)

### Correction factors for tripping thresholds

With regard to overload protection, no correction factors need to be applied. However, for the magnetic threshold values in use with 1000 Vdc with the previously described applicable diagrams, refer to the corresponding values for alternating current, multiplied by the correction factors given in the following table:

Circuit-breaker	$k_m$
T4V	1
T5V	0.9
T6L	0.9

### Circuit-breakers with thermomagnetic release for direct current

In [A]	32 <sup>(1)</sup>	50 <sup>(1)</sup>	80 <sup>(2)</sup>	100 <sup>(2)</sup>	125 <sup>(2)</sup>	160 <sup>(2)</sup>	200 <sup>(2)</sup>	250 <sup>(2)</sup>	320 <sup>(2)</sup>	400 <sup>(2)</sup>	500 <sup>(2)</sup>	630 <sup>(2)</sup>	800 <sup>(2)</sup>
T4V 250	■	■	■	■	■	■	■	■	-	-	-	-	-
T5V 400	-	-	-	-	-	-	-	-	■	■	-	-	-
T5V 630	-	-	-	-	-	-	-	-	-	-	■	-	-
T6L 630	-	-	-	-	-	-	-	-	-	-	-	■	-
T6L 800	-	-	-	-	-	-	-	-	-	-	-	-	■
I <sub>3</sub> = (10xI <sub>n</sub> ) [A]	320	500	-	-	-	-	-	-	-	-	-	-	-
I <sub>3</sub> = (5 - 10xI <sub>n</sub> ) [A]	-	-	400+800	500+1000	625+1250	800+1600	1000+2000	1250+2500	1600+3200	2000+4000	2500+5000	3150+6300	4000+8000

<sup>(1)</sup> Thermal threshold adjustable from 0.7 and 1 x I<sub>n</sub>; fixed magnetic threshold

<sup>(2)</sup> Thermal threshold adjustable from 0.7 and 1 x I<sub>n</sub>; magnetic threshold adjustable between 5 and 10 x I<sub>n</sub>.

## 5 Special applications

### Example

To ensure the protection of a user supplied with a network having the following characteristics:

Rated voltage	$U_r = 1000 \text{ Vdc}$
Short-circuit current	$I_k = 18 \text{ kA}$
Load current	$I_b = 420 \text{ A}$
Network with both polarities insulated from earth.	

From the table of available settings, the circuit-breaker to be used is:  
 T5V 630  $I_n=500$  four-pole  $I_{cu}@1000 \text{ Vdc} = 40 \text{ kA}$   
 Thermal trip threshold adjustable from  $(0.7-1) \times I_n$  therefore from 350 A to 500 A to be set at 0.84.

Magnetic trip threshold adjustable from  $(5-10) \times I_n$  which with correction factor  $K_{rn} = 0.9$  gives the following adjustment range: 2250 A to 4500 A. The magnetic threshold will be adjusted according to any conductors to be protected.

The connection of the poles must be as described in diagrams A or B.

A device which signals any first earth fault must be present.

With the same system data, if the network is carried out with a polarity connected to earth, the circuit-breaker must be connected as described in diagram C.

## 5 Special applications

### 1000 Vdc air switch disconnectors

The air switch disconnectors derived from the Emax air breakers are identified by the standard range code together with the code "/E MS".

These comply with the international Standard IEC 60947-3 and are especially suitable for use as bus-ties or principle isolators in direct current installations, for example in electrical traction applications.

The overall dimensions and the fixing points remain unaltered from those of standard breakers, and they can be fitted with various terminal kits and all the accessories for the Emax range; they are available in both withdrawable and fixed versions, and in three-pole version (up to 750 Vdc) and four-pole (up to 1000 Vdc).

The withdrawable breakers are assembled with special version fixed parts for applications of 750/1000 Vdc.

The range covers all installation requirements up to 1000 Vdc / 3200 A or up to 750 Vdc / 4000 A.

A breaking capacity equal to the rated short-time withstand current is attributed to these breakers when they are associated with a suitable external relay.

The following table shows the available versions and their relative electrical performance:

		E1B/E MS		E2N/E MS		E3H/E MS		E4H/E MS		E6H/E MS	
		[A]	[A]	[A]	[A]	[A]	[A]	[A]	[A]	[A]	[A]
Rated current (at 40 °C) $I_u$	[A]	800		1250		1250		3200		5000	
	[A]	1250		1600		1600		4000		6300	
	[A]			2000		2000					
	[A]					2500					
	[A]					3200					
Poles		3 4	3 4	3 4	3 4	3 4	3 4	3 4	3 4	3 4	
Rated service voltage $U_e$	[V]	750 1000	750 1000	750 1000	750 1000	750 1000	750 1000	750 1000	750 1000	750 1000	
Rated insulation voltage $U_i$	[V]	1000 1000	1000 1000	1000 1000	1000 1000	1000 1000	1000 1000	1000 1000	1000 1000	1000 1000	
Rated impulse withstand voltage $U_{imp}$	[kV]	12 12	12 12	12 12	12 12	12 12	12 12	12 12	12 12	12 12	
Rated short-time withstand current $I_{cw}$ (1s)	[kA]	20 20 <sup>(1)</sup>	25 25 <sup>(1)</sup>	40 40 <sup>(1)</sup>	65 65	65 65	65 65	65 65	65 65	65 65	
Rated making capacity $I_{cm}$	750V DC	[kA] 20 20	25 25	40 40	65 65	65 65	65 65	65 65	65 65	65 65	
	1000V DC	– 20	– 25	– 40	– 65	– 65	– 65	– 65	– 65	– 65	

**Note:** The breaking capacity  $I_{cu}$ , by means of external protection relay, with 500 ms maximum timing, is equal to the value of  $I_{cw}$  (1s).

(1) The performances at 750 V are:  
 for E1B/E MS  $I_{cw} = 25 \text{ kA}$ ,  
 for E2N/E MS  $I_{cw} = 40 \text{ kA}$  and  
 for E3H/E MS  $I_{cw} = 50 \text{ kA}$ .

## 5 Special applications

### Connection diagrams

Connection diagrams to be used according to the type of distribution system follow.

The risk of a double earth fault on different poles is assumed to be zero, that is, the fault current involves only one part of the breaker poles.

### Networks insulated from earth

The following diagrams may be used (the polarity may be inverted).

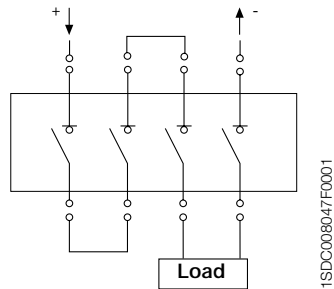

E) 3+1 poles in series (1000 Vdc)

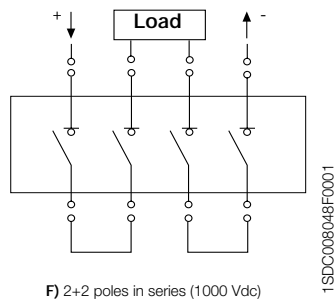

F) 2+2 poles in series (1000 Vdc)

## 5 Special applications

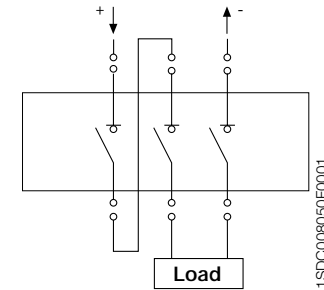

G) 2+1 poles in series (750 Vdc)

### Networks with one polarity connected to earth

The polarity connected to earth does not have to be interrupted (in the examples it is assumed that the polarity connected to earth is negative):

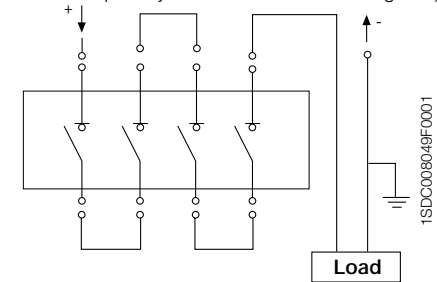

H) 4 poles in series (1000 Vdc)

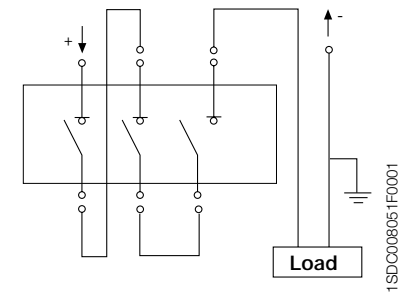

I) 3 poles in series (750 Vdc)

### Networks with median point of the supply source connected to earth

Only four-pole breakers may be used as in the configuration shown in diagram F).

## 5 Special applications

### 5.3.2 1000 Vac networks

#### Moulded-case circuit-breakers up to 1150 Vac

##### General characteristics

The circuit-breakers in the Tmax range up to 1150 V comply with the international standard IEC 60947-2.

These circuit breakers can be fitted with thermo-magnetic releases (for the smaller sizes) and with electronic releases. All installation requirements can be met with a range of available settings from 32 A to 800 A and with breaking capacity up to 20 kA at 1150 Vac.

##### Moulded-case circuit-breakers up to 1150 Vac

Rated uninterrupted current, <b>I<sub>u</sub></b>	[A]
Poles	Nr.
Rated service voltage, <b>U<sub>e</sub></b> (ac) 50-60Hz	[V]
Rated impulse withstand voltage, <b>U<sub>imp</sub></b>	[kV]
Rated insulation voltage, <b>U<sub>i</sub></b>	[V]
Test voltage at industrial frequency for 1 min.	[V]
Rated ultimate short-circuit breaking capacity, <b>I<sub>cu</sub></b>	[kA]
	(ac) 50-60 Hz 1000 V [kA]
	(ac) 50-60 Hz 1150 V [kA]
Rated service short-circuit breaking capacity, <b>I<sub>cs</sub></b>	[kA]
	(ac) 50-60 Hz 1000 V [kA]
	(ac) 50-60 Hz 1150 V [kA]
Rated short-circuit making capacity <b>I<sub>cm</sub></b>	[kA]
	(ac) 50-60 Hz 1000 V [kA]
	(ac) 50-60 Hz 1150 V [kA]
Utilisation category (EN 60947-2)	
Isolation behaviour	
Reference Standard	
Thermomagnetic releases	TMD
	TMA
Electronic releases	PR221DS/LS
	PR221DS/I
	PR222DS/P-LSI
	PR222DS/P-LSIG
	PR222DS/PD-LSI
	PR222DS/PD-LSIG
	PR222MP
Terminals	
Version	
Mechanical life	[No. operations]
	[No. operations per hours]
Basic dimension-fixed version <sup>(3)</sup>	3 poles W [mm]
	4 poles W [mm]
	D [mm]
	H [mm]
Weight	fixed 3/4 poles [kg]
	plug-in 3/4 poles [kg]
	withdrawable 3/4 poles [kg]

<sup>(1)</sup> Power supply only from above

<sup>(2)</sup> I<sub>cu</sub>=5kA

<sup>(3)</sup> I<sub>cu</sub>=7.6kA (630A) - 10kA (800A)

<sup>(4)</sup> Tmax T5630 is only available in the fixed version

<sup>(5)</sup> Circuit-breaker without high terminal covers

## 5 Special applications

The circuit-breakers in the range up to 115 V maintain the same dimensions as standard circuit breakers.

These circuit-breakers can also be fitted with the relevant range of standard accessories, with the exception of residual current releases.

The following tables show the electrical characteristics of the range:

T4		T5		T6	
250		400/630		630/800	
3, 4		3, 4		3, 4	
1000	1150	1000	1150	1000	1150
8	8	8	8	8	8
1000	1150	1000	1150	1000	1150
3500	3500	3500	3500	3500	3500
L	V	L	V <sup>(1)</sup>	L <sup>(1)</sup>	L <sup>(1)</sup>
12	20	12	20	12	20
	12		12		12
12	12	10	10	6	6
	6		6		6
24	40	24	40	24	24
	24		24		24
A		B (400 A) <sup>(2)</sup> /A (630 A)		B <sup>(3)</sup>	
■		■		■	
IEC 60947-2		IEC 60947-2		IEC 60947-2	
-	■	-	■	-	■
■	■	■	■	■	■
■	■	■	■	■	■
■	■	■	■	■	■
■	■	■	■	■	■
■	■	■	■	■	■
■	■	■	■	■	■
■	-	■	-	■	-
FC Cu		FC Cu		F-FC CuAl-R	
F, P, W	F	F, P, W <sup>(4)</sup>	F	F	
20000		20000		20000	
240		120		120	
105		140		210	
140		184		280	
103.5		103.5		103.5	
205		205		268	
2.35/3.05	2.35/3.05	3.25/4.15	3.25/4.15	9.5/12	
3.6/4.65		5.15/6.65			
3.85/4.9		5.4/6.9			

TERMINAL CAPTION

F=Front

FC Cu= Front for copper cables

FC CuAl=Front for CuAl cables

R= Rear orientated

## 5 Special applications

The following tables show the available releases.

### Circuit-breakers with electronic release for alternating currents

	In100	In250	In320	In400	In630	In800
<b>T4 250</b>	■	■	-	-	-	-
<b>T5 400</b>	-	-	■	■	-	-
<b>T5 630</b>	-	-	-	-	■	-
<b>T6L 630</b>	-	-	-	-	■	-
<b>T6L 800</b>	-	-	-	-	-	■
$I_n$ (1+10x In) [A] <sup>(1)</sup>	100+1000	250+2500	320+3200	400+4000	630+6300	800+8000
$I_n$ (1.5+12 x In) [A] <sup>(2)</sup>	150+1200	375+3000	480+3840	600+4800	945+7560	1200+9600

<sup>(1)</sup> PR221

<sup>(2)</sup> PR222

### Circuit-breakers with thermomagnetic release for alternating currents

In [A]	32 <sup>(1)</sup>	50 <sup>(1)</sup>	80 <sup>(2)</sup>	100 <sup>(2)</sup>	125 <sup>(2)</sup>	160 <sup>(2)</sup>	200 <sup>(2)</sup>	250 <sup>(2)</sup>	320 <sup>(2)</sup>	400 <sup>(2)</sup>	500 <sup>(2)</sup>	630 <sup>(2)</sup>	800 <sup>(2)</sup>
<b>T4V 250</b>	■	■	■	■	■	■	■	■	-	-	-	-	-
<b>T5V 400</b>	-	-	-	-	-	-	-	-	■	■	-	-	-
<b>T5V 630</b>	-	-	-	-	-	-	-	-	-	-	■	-	-
<b>T6L 630</b>	-	-	-	-	-	-	-	-	-	-	-	■	-
<b>T6L 800</b>	-	-	-	-	-	-	-	-	-	-	-	-	■
$I_n = (10x I_n)$ [A]	320	500	-	-	-	-	-	-	-	-	-	-	-
$I_n = (5-10x I_n)$ [A]	-	-	400+800	500+1000	625+1250	800+1600	1000+2000	1250+2500	1600+3200	2000+4000	2500+5000	31500+6300	4000+8000

<sup>(1)</sup> Thermal threshold adjustable from 0.7 and 1 x In; fixed magnetic threshold

<sup>(2)</sup> Thermal threshold adjustable from 0.7 and 1 x In; magnetic threshold adjustable between 5 and 10 x In.

### Air circuit-breakers and switch disconnectors up to 1150 Vac

For 1150 V alternating current applications, the following devices are available:

- **Circuit-breakers** in compliance with Standard IEC 60947-2.

The special version breakers up to 1150 Vac are identified by the standard range code together with the suffix “/E”, and are derived from the correspondent Emax standard breakers and retain the same versions, accessories and overall dimensions.

The Emax range of breakers is available in both withdrawable and fixed versions with three and four poles, and can be fitted with accessories and equipped with the full range of electronic releases and microprocessors (PR332/P-PR333/P-PR121-PR122-PR123).

- **Switch disconnectors** in compliance with Standard IEC 60947-3.

These breakers are identified by the code of the standard range, from which they are derived, together with the suffix “/E MS”. Three-pole and four-pole versions are available in both withdrawable and fixed versions with the same dimensions, accessory characteristics and installation as the standard switch disconnectors.

## 5 Special applications

The following tables show the electrical characteristics of the devices:

### Air circuit-breakers (up to 1150 Vac)

		X1B/E	E2B/E	E2N/E	E3H/E	E4H/E	E6H/E
Rated uninterrupted current (at 40 °C) $I_u$	[A]	630/800/1000/1250/1600	1600	2000	1250	1600	2000
Rated service voltage $U_e$	[V-]	1000	1150	1150	1150	1150	1150
Rated insulation voltage $U_i$	[V-]	1000	1250	1250	1250	1250	1250
Rated ultimate breaking capacity under short-circuit $I_{cu}$							
1000 V	[kA]	20	20	20	30	30	30
1150 V	[kA]		20	20	30	30	30
Rated service breaking capacity under short-circuit $I_{cs}$							
1000 V	[kA]	20	20	20	30	30	30
1150 V	[kA]		20	20	30	30	30
Rated short-time withstand current $I_{sw}$ (1s)							
1000 V	[kA]	20	20	20	30	30	30
1150 V	[kA]		20	20	30	30	30
Rated making capacity under short-circuit (peak value) $I_{cm}$							
1000 V	[kA]	40	40	40	63	63	63
1150 V	[kA]		40	40	63	63	63

### Air switch disconnectors (up to 1150 Vac)

		X1B/E MS	E2B/E MS	E2N/E MS	E3H/E MS	E4H/E MS	E6H/E MS
Rated current (at 40 °C) $I_u$	[A]	1000	1600	1250	1250	3200	5000
	[A]	1250	2000	1600	1600	4000	6300
	[A]	1600		2000	2000		
	[A]				2500		
	[A]				3200		
Poles		3/4	3/4	3/4	3/4	3/4	3/4
Rated service voltage $U_e$	[V]	1000	1150	1150	1150	1150	1150
Rated insulation voltage $U_i$	[V]	1000	1250	1250	1250	1250	1250
Rated impulse withstand voltage $U_{imp}$	[kV]	12	12	12	12	12	12
Rated short-time withstand current $I_{sw}$ (1s)	[kA]	20	20	30	30 <sup>(1)</sup>	65	65
Rated making capacity $I_{cm}$ (peak value)	[kA]	40	40	63	63 <sup>(2)</sup>	143	143

Note: The breaking capacity  $I_{cu}$ , by means of external protection relay, with 500 ms maximum timing, is equal to the value of  $I_{sw}$  (1s).

<sup>(1)</sup> The performance at 1000V is 50 kA

<sup>(2)</sup> The performance at 1000V is 105 kA

## 5 Special applications

### 5.4 Automatic Transfer Switches

In the electrical plants, where a high reliability is required from the power supply source because the operation cycle cannot be interrupted and the risk of a lack of power supply is unacceptable, an emergency line supply is indispensable to avoid the loss of large quantities of data, damages to working processes, plant stops etc.

For these reasons, transfer switch devices are used mainly for:

- power supply of hotels and airports;
- surgical rooms and primary services in hospitals;
- power supply of UPS groups;
- databanks, telecommunication systems, PC rooms;
- power supply of industrial lines for continuous processes.

ATS010 is the solution offered by ABB: it is an automatic transfer switch system with micro-processor based technology which allows switching of the supply from the normal line (N-Line) to the emergency line (E-Line) in case any of the following anomalies occurs on the main network:

- overvoltages and voltage dips;
- lack of one of the phases;
- asymmetries in the phase cycle;
- frequency values out of the setting range.

Then, when the network standard parameters are recovered, the system switches again the power supply to the main network (N-Line).

ATS010 is used in systems with two distinct supply lines connected to the same busbar system and functioning independently ("island condition"): the first one is used as normal supply line, the second is used for emergency power supply from a generator system. It is also possible to provide the system with a device to disconnect the non-priority loads when the network is supplied from the E-Line.

The following scheme shows a plant having a safety auxiliary power supply:

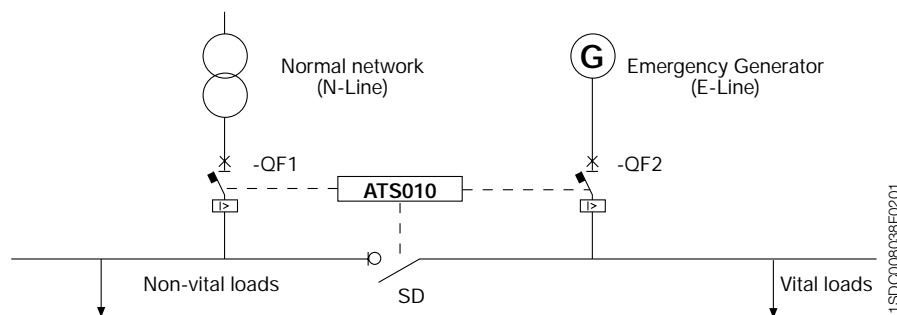

## 5 Special applications

ATS010 device is interfaced by means of appropriate terminals:

- with the protection circuit-breakers of the N-Line and of the E-Line, motorized and mechanically interlocked, to detect their status and send opening and closing commands according to the set time delays;
- with the control card of the Gen set to control its status and send start and stop commands;
- with any further signals coming from the plant in order to block the switching logic;
- with the N-Line to detect any possible anomaly and with the E-Line to verify the voltage presence;
- with an additional device to disconnect non-priority loads;
- with an auxiliary power supply at 24 Vdc  $\pm$  20% (or 48 Vdc  $\pm$  10%). This supply source shall be present also in case of lack of voltage on both lines (N-Line and E-Line).

The circuit-breakers used to switch from the N-line to the E-line shall have all the necessary accessories and shall be properly interlocked in order to guarantee the correct working of the plant. The following accessories are required:

#### Moulded-case circuit-breakers Tmax (T4-T5-T6-T7) and SACE Isomax (S7):

- motor operator from 48 V to 110 V dc or up to 250V ac;
- trip signaling contact;
- open/closed signaling contact;
- racked-in signaling contact in case of plug-in or withdrawable circuit-breakers;
- mechanical interlock between two circuit-breakers.

#### Air circuit-breakers Emax:

- charging spring motor;
- shunt opening release;
- shunt closing release;
- trip signaling contact;
- open/closed signaling contacts;
- racked-in signaling contact in case of withdrawable circuit-breakers;
- mechanical interlock between two circuit-breakers.

### Switching strategies

According to the application where ATS010 device is used, two different switching strategies can be chosen.

**Strategy 1:** this strategy is used when an auxiliary supply source is available for the supply of the motor operators of the circuit-breakers; the switching sequence is as follows:

- normal line anomaly detection;
- normal line circuit-breaker opening and Gen Set starting;
- waiting for presence of Gen Set voltage and emergency circuit-breaker closing.



## 5 Special applications

For example, strategy 1 is used for systems in which a redundant 110 V auxiliary power supply is available (MV/LV substations); the plant is designed so that the auxiliary voltage is always present even when neither the normal line nor the Gen Set are active. In this case, the auxiliary power supply can be used to feed the motor operators and/or the shunt opening and closing releases of the circuit-breakers. ATSO10 operates the circuit-breakers regardless of the presence of the network and of the Gen Set.

**Strategy 2:** this strategy is absolutely necessary when the power supply for the auxiliary accessories of the circuit-breakers is directly derived from the network and the Gen Set, since a safety auxiliary power supply is not available; in this case, before operating the circuit-breakers, ATSO10 waits for availability of normal line or emergency line voltage: normal line or Gen Set. The switching sequence is as follows:

- normal line anomaly detection;
- Gen Set starting;
- waiting for presence of Gen Set voltage and normal line circuit-breaker opening;
- Gen Set circuit-breaker closing.

**Note:** in both strategies, it is necessary to provide an auxiliary power supply for ATSO10.

### Operating modes

By using the front selector it is possible to choose one of the following six operating modes:

#### TEST:

This operating mode is useful to test the Gen Set start and therefore to test the emergency line power supply status without disconnecting normal line power supply.

#### AUTOMATIC:

The transfer switch logic is ON and checks both the circuit-breakers as well as the generator. In case of normal line anomalies, the transfer switch procedure begins from normal to emergency line and viceversa when normal line voltage become available again.

## 5 Special applications

### MANUAL:

The MANUAL mode offers a choice between the following possibilities:

#### 1. Normal ON

The emergency line circuit-breaker is forced to open and the normal line circuit-breaker is forced to close; the Gen Set is stopped and the transfer switch logic is disabled.

This selector position guarantees that the emergency line is not closed and that the Gen Set is not running; this position is useful when the user wants to carry out maintenance on the emergency line or on the Gen Set (in these cases it is advisable to install mechanical lock in open position for the emergency line circuit-breaker).

#### 2. Normal – Emergency OFF (maintenance)

Both circuit-breakers (N-Line and E-Line) are forced in open position. It is useful when all loads are to be disconnected from the power supply sources, for example to carry out maintenance on the plant (in these cases, it is advisable to mechanically lock both circuit-breakers in the open position).

#### 3. Gen Set START

The START command of the Gen Set has been activated through the proper output. The circuit-breakers are not operated and the transfer switch logic is disabled.

When emergency line voltage is present and switching is enabled, it is possible to switch the selector to 'Emergency ON' position in order to force supply from the emergency line.

#### 4. Emergency ON

Power supply is forced from the emergency line. Before switching to this position, 'Gen-Set START' operating mode is activated and shall be present until switching is enabled as previously described.

## 5 Special applications

### Setting of parameters

All the parameters for the functioning of ATSO10 can be simply adjusted through dip-switches or trimmers.

Rated voltage for three-phase or single-phase plant

The following parameters of the N-Line can be set through dip-switches:

- network rated voltage value (from 100 V up to 500 V);
- power supply type (three-phase or single-phase);
- frequency value (50 Hz or 60 Hz);
- type of strategy.

Note: Voltages higher than 500 V can be reached by using VTs (voltage transformers); in this case the setting of the voltage value shall consider the transformation ratio.

1-4: UN

4	ON	OFF
3	■	
2		■
1		■

100V 220V  
380V 400V

5: NOT USED

8	ON	OFF
7	■	
6	■	
5	■	
4	■	
3	■	
2	■	
1	■	

6: OFF=1~  
ON=3~

7: OFF=50Hz  
ON=60Hz

8: OFF=Strategy1  
ON=Strategy2

1SDC00052F0001

The figure below shows all the possible voltage values which can be set by the dip-switches from 1 to 4.

100V	4	ON	OFF
	3		■
	2		■
	1		■

115V	4	ON	OFF
	3		■
	2		■
	1	■	

120V	4	ON	OFF
	3		■
	2	■	
	1		■

208V	4	ON	OFF
	3		■
	2	■	
	1	■	

## 5 Special applications

220V	4	ON	OFF
	3	■	
	2		■
	1		■

230V	4	ON	OFF
	3	■	
	2		■
	1	■	

240V	4	ON	OFF
	3	■	
	2	■	
	1		■

277V	4	ON	OFF
	3	■	
	2	■	
	1	■	

347V	4	ON	OFF
	3	■	
	2		■
	1		■

380V	4	ON	OFF
	3	■	
	2		■
	1	■	

400V	4	ON	OFF
	3	■	
	2	■	
	1		■

415V	4	ON	OFF
	3		■
	2	■	
	1	■	

440V	4	ON	OFF
	3	■	
	2		■
	1		■

480V	4	ON	OFF
	3	■	
	2		■
	1	■	

500V	4	ON	OFF
	3	■	
	2	■	
	1		■

Note: the black square shows the dip-switch position.

## 5 Special applications

### Overvoltage threshold

According to the load characteristics, it is possible to set the voltage range outside which the N-Line supply cannot be accepted and switching to the E-Line is necessary.

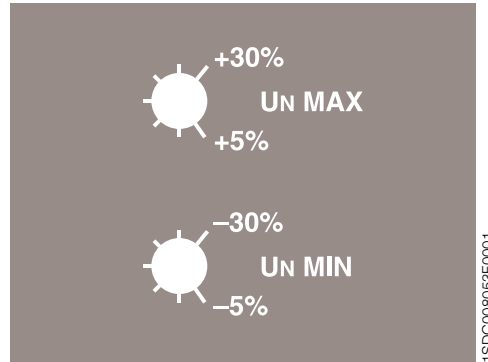

### Transfer switch delay configuration

Transfer switch delays can be set through special trimmers. Setting times and relevant purposes are reported below:

#### T1 = 0 ÷ 32 s CB-N OPEN

Delay time from net anomaly detection to N-Line CB opening. It is used to avoid transfer switching in case of short voltage dips.

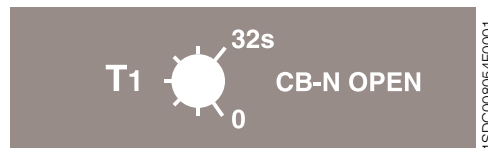

#### T2 = 0 ÷ 32 s GEN-SET START

Delay time from net anomaly detection to Gen set start command. It is used to prevent from transfer switching in case of short voltage dips.

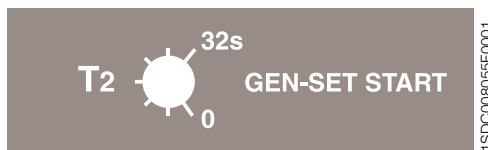

## 5 Special applications

#### T3= 0 ÷ 254 s GEN-SET STOP

Delay time from N-Line return to Gen set stop command. It is used when the Generator needs a cooling time after the disconnection of the load (opening of the E-Line circuit-breaker).

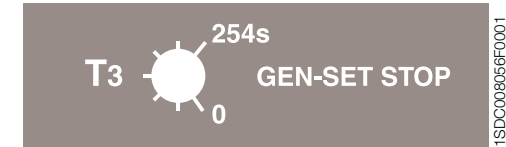

#### T4= 0 ÷ 254 s BACK TO NORMAL LINE OK

Delay time necessary for N-Line voltage to establish, before inverse switching procedure is started.

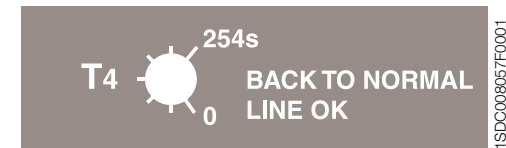

#### T5 = 0 ÷ 32 s CB-E CLOSE

Delay time to allow the gen-set voltage to stabilize: after starting the generator and detecting a voltage on the emergency line, the ATS010 unit waits for a time T5 before considering this voltage stable.

In Strategy 1, after detecting the gen-set voltage, the ATS010 unit waits for time T5 before closing CB-E.

In strategy 2, the ATS010 unit cannot open or close the breakers unless there is a stable voltage source. Therefore, the unit waits for a time T5 before opening CB-N. If, however, a time delay T1 since voltage loss has not elapsed, the ATS010 unit waits until T1 has elapsed, and only then opens CB-N.

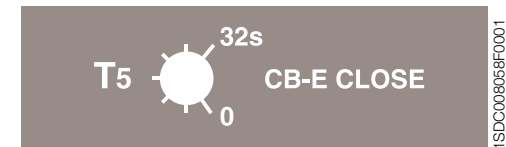

## 5 Special applications

### Check on the plant and on the circuit-breakers

ATS010 can be used in plants with the following characteristics:

- the Gen set shall function independently ("island" condition);
- rated voltage and frequency of the plants are included within the given ranges;
- ATS010 supply is guaranteed even if N-Line and E-Line voltages are missing.

The two circuit-breakers controlled by ATS are to be:

- mechanically interlocked;
- of the prescribed type and size;
- equipped with the prescribed accessories.

### References Standards

EN 50178 (1997): "Electronic equipment for use in power installations"  
Compliance with "Low Voltage Directive" (LVD) no. 73/23/EEC and  
"Electromagnetic Compatibility Directive" (EMC) no. 89/336/EEC.  
Electromagnetic compatibility: EN 50081-2, EN 50082-2  
Environmental conditions: IEC 60068-2-1, IEC 60068-2-2, IEC 60068-2-3.

#### ATS010 - main technical characteristics

Rated power supply voltage (galvanically isolated from the ground)	24 Vdc $\pm$ 20% 48 Vdc $\pm$ 10% (maximum ripple $\pm$ 5%)
Maximum power consumption	5 W @ 24 Vdc 10 W @ 48 Vdc
Rated power (N-Line voltage present and CBs not operated)	1,8 W @ 24 Vdc 4,5 W @ 48 Vdc
Operating temperature	-25 °C...+70 °C
Maximum humidity	90 % without condensation
Storing temperature	-20 °C.....+80 °C
Degree of protection	IP54 (front panel)
Dimensions (H x W x D)	144 x 144 x 85
Weight [kg]	0,8

#### Normal line voltage sensor

Normal line rated voltage	100...500 Vac with direct connection Over 500 Vac with external voltage transformers
Rated frequency	50 Hz / 60 Hz
Impulse withstand voltage on L1, L2, L3 inputs	6 kV

#### Motor operators - shunt opening/closing releases

Tmax T4-T5-T6 Isomax S7	Up to 250 Vac From 48 Vdc to 110 Vdc
E <sub>max</sub>	Up to 250 Vac From 24 Vdc to 110 Vdc

## 6 Switchboards

### 6.1 Electrical switchboards

The switchboard is a combination of one or more low voltage switching, protection and other devices assembled in one or more enclosure so as to satisfy the requirements regarding safety and to allow the functions for which it was designed to be carried out.

A switchboard consists of a container, termed enclosure by the relevant Standards (which has the function of support and mechanical protection of the components contained within), and the electrical equipment, which consists of devices, internal connections and input and output terminals for connection with the system.

The reference Standard is IEC 60439-1 published in 1999, titled "Low-voltage switchgear and controlgear assemblies - Part 1: Type-tested and partially type-tested assemblies", approved by CENELEC code number EN 60439-1.

Supplementary calculation guides are:

IEC 60890 "A method of temperature-rise assessment by extrapolation for partially type-tested assemblies (PTTA) of low-voltage switchgear and controlgear".

IEC 61117 "A method for assessing the short-circuit withstand strength of partially type-tested assemblies (PTTA)".

IEC 60865-1 "Short-circuit currents - Calculation of effects - Part 1: Definitions and calculation methods".

Standard IEC 60439-1 sets out the requirements relating to the construction, safety and maintainability of electrical switchboards, and identifies the nominal characteristics, the operational environmental conditions, the mechanical and electrical requirements and the performance regulations.

The type-tests and individual tests are defined, as well as the method of their execution and the criteria necessary for the evaluation of the results.

Standard IEC 60439-1 distinguishes between the two types of switchboard: TTA (type-tested assemblies) and PTTA (partially type-tested assemblies).

By "type-tested assemblies" (TTA), it is meant a low voltage switchgear and controlgear assemblies conforming to an established type or system without deviations likely to significantly influence the performance from the typical assembly verified to be in accordance with the Standard prescriptions.

TTA switchboards are assemblies derived directly from a prototype designed in all details and subjected to type-tests; as the type-tests are very complex, switchboards designed by a manufacturer with a sound technical and financial basis are referred to. Nevertheless, TTA assemblies can be mounted by a panel builder or installer who follows the manufacturer's instructions; deviations from the prototype are only allowed if they do not significantly change the performance compared with the type-tested equipment.

## 6 Switchboards

By "partially type-tested assemblies" (PTTA), it is meant a low voltage and controlgear assembly, tested only with a part of the type-tests; some tests may be substituted by extrapolation which are calculations based on experimental results obtained from assemblies which have passed the type-tests. Verifications through simplified measurements or calculations, allowed as an alternative to type tests, concern heating, short circuit withstand and insulation.

Standard IEC 60439-1 states that some steps of assembly may take place outside the factory of the manufacturer, provided the assembly is performed in accordance with the manufacturer's instructions.

The installer may use commercial assembly kits to realize a suitable switchboard configuration.

The same Standard specifies a division of responsibility between the manufacturer and the assembler in Table 7: "List of verifications and tests to be performed on TTA and PTTA" in which the type-tests and individual tests to be carried out on the assembly are detailed.

The type-tests verify the compliance of the prototype with the requirements of the Standard, and are generally under the responsibility of the manufacturer, who must also supply instructions for the production and assembly of the switchboard. The assembler has responsibility for the selection and assembly of components in accordance with the instructions supplied and must confirm compliance with the Standards through the previously stated checks in the case of switchboards that deviate from a tested prototype. Routine tests must also be carried out on every example produced.

The distinction between TTA and PTTA switchgear and controlgear assemblies has no relevance to the declaration of conformity with Standard IEC 60439-1, in so far as the switchboard must comply with this Standard.

## 6 Switchboards

### List of verifications and tests to be performed on TTA and PTTA

No.	Characteristics to be checked	Sub-clauses	TTA	PTTA
1	Temperature-rise limits	8.2.1	Verification of temperature-rise limits by test (type test)	Verification of temperature-rise limits by test or extrapolation
2	Dielectric properties	8.2.2	Verification of dielectric properties by test (type test)	Verification of dielectric properties by test according to 8.2.2 or 8.3.2, or verification of insulation resistance according to 8.3.4 (see No. 9 and 11)
3	Short-circuit withstand strength	8.2.3	Verification of the short-circuit withstand strength by test (type test)	Verification of the short-circuit withstand strength by test or by extrapolation from similar type-tested arrangements
4	Effectiveness of the protective circuit	8.2.4		
	Effective connection between the exposed conductive parts of the ASSEMBLY and the protective circuit	8.2.4.1	Verification of the effective connection between the exposed conductive parts of the ASSEMBLY and the protective circuit by inspection or by resistance measurement (type test)	Verification of the effective connection between the exposed conductive parts of the ASSEMBLY and the protective circuit by inspection or by resistance measurement
	Short-circuit withstand strength of the protective circuit	8.2.4.2	Verification of the short-circuit withstand strength of the protective circuit by test (type test)	Verification of the short-circuit withstand strength of the protective circuit by test or appropriate design and arrangement of the protective conductor (see 7.4.3.1.1, last paragraph)
5	Clearances and creepage distances	8.2.5	Verification of the clearances and creepage distances (type test)	Verification of clearances and creepage distances
6	Mechanical operation	8.2.6	Verification of mechanical operation (type test)	Verification of mechanical operation
7	Degree of protection	8.2.7	Verification of the degree of protection (type test)	Verification of the degree of protection
8	Wiring, electrical operation	8.3.1	Inspection of the ASSEMBLY including inspection of wiring and, if necessary, electrical operation test (routine test)	Inspection of the ASSEMBLY including inspection of wiring and, if necessary, electrical operation test
9	Insulation	8.3.2	Dielectric test (routine test)	Dielectric test or verification of insulation resistance according to 8.3.4 (see No. 2 and 11)
10	Protective measures	8.3.3	Checking of protective measures and of the electrical continuity of the protective circuits (routine test)	Checking of protective measures
11	Insulation resistance	8.3.4		Verification of insulation resistance unless test according to 8.2.2 or 8.3.2 has been made (see No. 2 and 9)

## 6 Switchboards

### Degrees of protection

The degree of protection IP indicates a level of protection provided by the assembly against access to or contact with live parts, against ingress of solid foreign bodies and against the ingress of liquid. The IP code is the system used for the identification of the degree of protection, in compliance with the requirements of Standard IEC 60529. Unless otherwise specified by the manufacturer, the degree of protection applies to the complete switchboard, assembled and installed for normal use (with door closed).

The manufacturer shall also state the degree of protection applicable to particular configurations which may arise in service, such as the degree of protection with the door open or with devices removed or withdrawn.

#### Elements of the IP Code and their meanings

Element	Numerals or letters	Meaning for the protection of equipment	Meaning for the protection of persons	Ref.
First characteristic numeral	IP	Against ingress of the solid foreign objects	Against access to hazardous parts with	Cl.5
	0	(non-protected)	(non-protected)	
	1	≥ 50 mm diameter	back of hand	
	2	≥ 12.5 mm diameter	finger	
	3	≥ 2.5 mm diameter	tool	
	4	≥ 1.0 mm diameter	wire	
	5	dust-protected	wire	
Second characteristic numeral	6	dust-tight	wire	Cl.6
	0	Against ingress of water with harmful effects		
	1	(non-protected)		
	2	vertically dripping		
	3	dripping (15° tilted)		
	4	spraying		
	5	splashing		
	6	jetting		
	7	powerful jetting		
Additional letter (optional)	8	temporary immersion	Against access to hazardous parts with	Cl.7
	A	continuous immersion	back of hand	
	B		finger	
	C		tool	
	D		wire	
Supplementary letter (optional)		Supplementary information specific to:		Cl.8
	A	High voltage apparatus		
	B	Motion during water test		
	C	Stationary during water test		
	D	Weather conditions		

## 6 Switchboards

### Form of separation and classification of switchboards

#### Forms of internal separation

By form of separation it is meant the type of subdivision provided within the switchboard. Separation by means of barriers or partitions (metallic or insulating) may have the function to:

- provide protection against direct contact (at least IPXXB) in the case of access to a part of the switchboard which is not live, with respect to the rest of the switchboard which remains live;
- reduce the risk of starting or propagating an internal arc;
- impede the passage of solid bodies between different parts of the switchboard (degree of protection of at least IP2X).

A partition is a separation element between two parts, while a barrier protects the operator from direct contact and from arcing effects from any interruption devices in the normal access direction.

The following table from Standard IEC 60439-1 highlights typical forms of separation which can be obtained using barriers or partitions:

Main criteria	Subcriteria	Form
No separation		Form 1
Separation of busbars from the functional units	Terminals for external conductors not separated from busbars	Form 2a
	Terminals for external conductors separated from busbars	Form 2b
Separation of busbars from the functional units and separation of all functional units from one another.	Terminals for external conductors not separated from busbars	Form 3a
	Separation of the terminals for external conductors from the functional units, but not from each other	Form 3b
Separation of busbars from the functional units and separation of all functional units from one another, including the terminals for external conductors which are an integral part of the functional unit	Terminals for external conductors in the same compartment as the associated functional unit	Form 4a
	Terminals for external conductors not in the same compartment as the associated functional unit, but in individual, separate, enclosed protected spaces or compartments	Form 4b

## 6 Switchboards

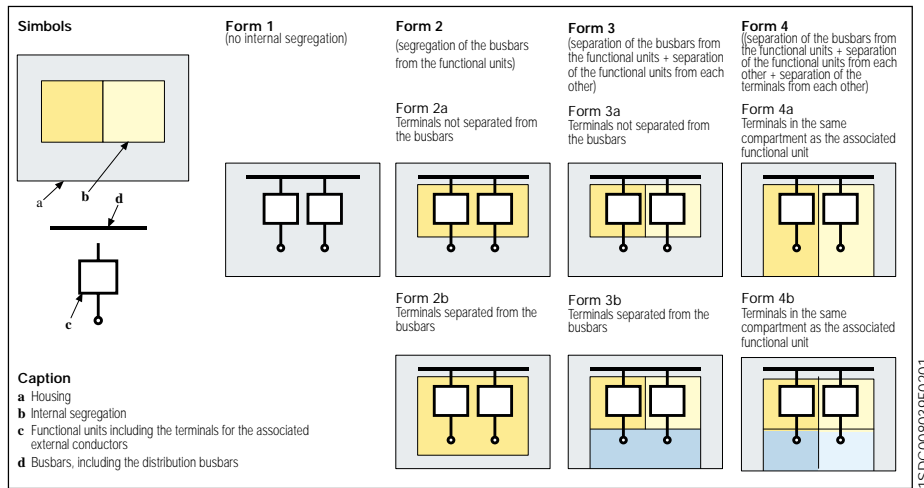

### Classification

Different classifications of electrical switchboard exist, depending on a range of factors.

Based on construction type, Standard IEC 60439-1 firstly distinguishes between open and enclosed assemblies.

A switchboard is enclosed when it comprises protective panels on all sides, providing a degree of protection against direct contact of at least IPXXB. Switchboards used in normal environments must be enclosed.

Open switchboards, with or without front covering, which have the live parts accessible. These switchboards may only be used in electrical plants.

With regard to external design, switchboards are divided into the following categories:

#### - Cubicle-type assembly

Used for large scale control and distribution equipment; multi-cubicle-type assembly can be obtained by placing cubicles side by side.

## 6 Switchboards

#### - Desk-type assembly

Used for the control of machinery or complex systems in the mechanical, iron and steel, and chemical industries.

#### - Box-type assembly

Characterized by wall mounting, either mounted on a wall or flush-fitting; these switchboards are generally used for distribution at department or zone level in industrial environments and in the tertiary sector.

#### - Multi-box-type assembly

Each box, generally protected and flanged, contains a functional unit which may be an automatic circuit-breaker, a starter, a socket complete with locking switch or circuit-breaker.

With regard to the intended function, switchboards may be divided into the following types:

#### - Main distribution boards

Main distribution boards are generally installed immediately downstream of MV/LV transformers, or of generators; they are also termed power centres. Main distribution boards comprise one or more incoming units, busbar connectors, and a relatively smaller number of output units.

#### - Secondary distribution boards

Secondary distribution boards include a wide range of switchboards for the distribution of power, and are equipped with a single input unit and numerous output units.

#### - Motor operation boards

Motor control boards are designed for the control and centralised protection of motors: therefore they comprise the relative coordinated devices for operation and protection, and auxiliary control and signalling devices.

#### - Control, measurement and protection boards

Control, measurement and protection boards generally consist of desks containing mainly equipment for the control, monitoring and measurement of industrial processes and systems.

#### - Machine-side boards

Machine-side boards are functionally similar to the above; their role is to provide an interface between the machine with the power supply and the operator.

#### - Assemblies for construction sites (ASC)

Assemblies for construction sites may be of different sizes, from a simple plug and socket assembly to true distribution boards with enclosures of metal or insulating material. They are generally mobile or, in any case, transportable.

## 6 Switchboards

### Method of temperature rise assessment by extrapolation for partially tested assemblies (PTTA)

For PTTA assemblies, the temperature rise can be determined by laboratory tests or calculations, which can be carried out in accordance with Standard IEC 60890. The formulae and coefficients given in this Standard are deduced from measurements taken from numerous switchboards, and the validity of the method has been checked by comparison with the test results.

This method does not cover the whole range of low voltage switchgear and controlgear assemblies since it has been developed under precise hypotheses which limit the applications; this can however be correct, suited and integrated with other calculation procedures which can be demonstrated to have a technical basis.

Standard IEC 60890 serves to determine the temperature rise of the air inside the switchboard caused by the energy dissipated by the devices and conductors installed within the switchboard.

To calculate the temperature rise of the air inside an enclosure, once the requirements of the Standard have been met, the following must be considered:

- Dimensions of the enclosure.
- Type of installation:
  - enclosure open to air on all sides;
  - wall-mounted enclosure;
  - enclosure designed for mounting in extremities;
  - enclosure in an internal position in a multi-compartment switchboard;
- Any ventilation openings, and their dimensions.
- Number of horizontal internal separators;
- Power losses from the effective current flowing through any device and conductor installed within the switchboard or compartment.

The Standard allows the calculation of temperature rise of the air at mid-height and at the highest point of the switchboard. Once the values are calculated, it must be evaluated if the switchboard can comply with the requirements relating to the set limits at certain points within the same switchboard.

The Annex B explains the calculation method described in the Standard.

ABB supplies the client with calculation software which allows the temperature rise inside the switchboard to be calculated quickly.

## 6 Switchboards

### 6.2 MNS switchboards

MNS systems are suitable for applications in all fields concerning the generation, distribution and use of electrical energy; e. g., they can be used as:

- main and sub-distribution boards;
- motor power supply of MCCs (Motor Control Centres);
- automation switchboards.

The MNS system is a framework construction with maintenance-free bolted connections which can be equipped as required with standardized components and can be adapted to any application. The consistent application of the modular principle both in electrical and mechanical design permits optional selection of the structural design, interior arrangement and degree of protection according to the operating and environmental conditions.

The design and material used for the MNS system largely prevent the occurrence of electric arcs, or provide for arc extinguishing within a short time. The MNS System complies with the requirements laid down in VDE0660 Part 500 as well as IEC 61641 and has furthermore been subjected to extensive accidental arc tests by an independent institute.

The MNS system offers the user many alternative solutions and notable advantages in comparison with conventional-type installations:

- compact, space-saving design;
- back-to-back arrangement;
- optimized energy distribution in the cubicles;
- easy project and detail engineering through standardized components;
- comprehensive range of standardized modules;
- various design levels depending on operating and environmental conditions;
- easy combination of the different equipment systems, such as fixed and withdrawable modules in a single cubicle;
- possibility of arc-proof design (standard design with fixed module design);
- possibility of earthquake-, vibration- and shock-proof design;
- easy assembly without special tools;
- easy conversion and retrofit;
- largely maintenance-free;
- high operational reliability;
- high safety for human beings.

The basic elements of the frame are C-sections with holes at 25 mm intervals in compliance with Standard DIN 43660. All frame parts are secured maintenance-free with tapping screws or ESLOK screws. Based on the basic grid size of 25 mm, frames can be constructed for the various cubicle types without any special tools. Single or multi-cubicle switchgear assemblies for front or front and rear operations are possible.

Different designs are available, depending on the enclosure required:

- single equipment compartment door;
- double equipment compartment door;
- equipment and cable compartment door;
- module doors and/or withdrawable module covers and cable compartment door.

The bottom side of the cubicle can be provided with floor plates. With the aid of flanged plates, cable ducts can be provided to suit all requirements. Doors and cladding can be provided with one or more ventilation opening, roof plates can be provided with metallic grid (IP 30 – IP40) or with ventilation chimney (IP 40, 41, 42).



## 6 Switchboards

Depending on the requirements, a frame structure can be subdivided into the following compartments (functional areas):

- equipment compartment;
- busbar compartment;
- cable compartment.

The equipment compartment holds the equipment modules, the busbar compartment contains the busbars and distribution bars, the cable compartment houses the incoming and outgoing cables (optionally from above and from below) with the wiring required for connecting the modules as well as the supporting devices (cable mounting rails, cable connection parts, parallel connections, wiring ducts, etc.). The functional compartments of a cubicle as well as the cubicles themselves can be separated by partitions. Horizontal partitions with or without ventilation openings can also be inserted between the compartments.

All incoming/outgoing feeder and bus coupler cubicles include one switching device. These devices can be fixed-mounted switch disconnectors, fixed-mounted or withdrawable air or moulded-case circuit-breakers.

This type of cubicles is subdivided into equipment and busbar compartments; their size (H x W) is 2200 mm x 400 mm / 1200 mm x 600 mm, and the depth depends on the dimensions of the switchgear used.

Cubicles with air circuit-breakers up to 2000 A can be built in the reduced dimensioned version (W = 400 mm).

It is possible to interconnect cubicles to form optimal delivery units with a maximum width of 3000 mm.

### 6.3 ArTu distribution switchboards

The range of ABB SACE ArTu distribution switchboards provides a complete and integrated offer of switchboards and kit systems for constructing primary and secondary low voltage distribution switchboards.

With a single range of accessories and starting from simple assembly kits, the ArTu switchboards make it possible to assemble a wide range of configurations mounting modular, moulded-case and air circuit-breakers, with any internal separation up to Form 4.

ABB SACE offers a series of standardized kits, consisting of pre-drilled plates and panels for the installation of the whole range of circuit-breakers type System pro M, Isomax, Tmax and Emax X1, E1, E2, E3, E4 without the need of additional drilling operations or adaptations.

Special consideration has been given to cabling requirements, providing special seats to fix the plastic cabling duct horizontally and vertically.

Standardization of the components is extended to internal separation of the switchboard: in ArTu switchboards, separation is easily carried out and it does not require either construction of "made-to-measure" switchboards or any additional sheet cutting, bending or drilling work.

ArTu switchboards are characterized by the following features:

- integrated range of modular metalwork structures up to 4000 A with common accessories;
- possibility of fulfilling all application requirements in terms of installation (wall-mounting, floor-mounting, monoblock and cabinet kits) and degree of protection (IP31, IP41, IP43, IP65);
- structure made of hot-galvanized sheet;

## 6 Switchboards

- maximum integration with modular devices and ABB SACE moulded-case and air circuit-breakers;
- minimum switchboard assembly times thanks to the simplicity of the kits, the standardization of the small assembly items, the self-supporting elements and the presence of clear reference points for assembly of the plates and panels;
- separations in kits up to Form 4.

The range of ArTu switchboards includes four versions, which can be equipped with the same accessories.

### ArTu L series

ArTu L series consists of a range of modular switchboard kits, with a capacity of 24 modules per row and degree of protection IP31 (without door) or IP43 (basic version with door). These switchboards can be wall- or floor-mounted:

- wall-mounted ArTu L series, with heights of 600, 800, 1000 and 1200 mm, depth 200 mm, width 700 mm. Both System pro M modular devices and moulded-case circuit-breakers Tmax T1-T2-T3 are housed inside this switchboard series;
- floor-mounted ArTu L series, with heights of 1400, 1600, 1800 and 2000 mm, depth 240 mm, width 700 mm. System pro M modular devices, moulded-case circuit-breakers type Tmax T1-T2-T3-T4-T5-T6 (fixed version with front terminals) are housed inside this switchboard series.

### ArTu M series

ArTu M series consists of a modular range of monoblock switchboards for wall-mounted (with depths of 150 and 200 mm with IP65 degree of protection) or floor-mounted (with depth of 250 mm and IP31 or IP65 degrees of protection) installations, in which it is possible to mount System pro M modular devices and Tmax T1-T2-T3 moulded-case circuit-breakers on a DIN rail. ArTu M series of floor-mounted switchboards can be equipped with Tmax series.

### ArTu K series

ArTu K series consists of a range of modular switchboard kits for floor-mounted installation with four different depths (250, 350, 600, 800 and 1000 mm) and with degree of protection IP31 (without front door), IP41 (with front door and ventilated side panels) or IP65 (with front door and blind side panels), in which it is possible to mount System pro M modular devices, the whole range of moulded-case circuit-breakers Tmax and Isomax, and Emax circuit-breakers X1, E1, E2, E3 and E4.

ArTu switchboards have three functional widths:

- 400 mm, for the installation of moulded-case circuit-breakers up to 630 A (T5);
- 600 mm, which is the basic dimension for the installation of all the apparatus;
- 800 mm, for the creation of the side cable container within the structure of the floor-mounted switchboard or for the use of panels with the same width.

The available internal space varies in height from 600 mm (wall-mounted L series) to 2000 mm (floor-mounted M series and K series), thus offering a possible solution for the most varied application requirements.

## 6 Switchboards

### ArTu PB Series (Panelboard and Pan Assembly)

The ArTu line is now upgraded with the new ArTu PB Panelboard solution. The ArTu PB Panelboard is suitable for distribution applications with an incoming up to 800A and outgoing feeders up to 250A. The ArTu PB Panelboard is extremely sturdy thanks to its new designed framework and it is available both in the wall-mounted version as well as in the floor-mounted one. ArTu PB Panelboard customisation is extremely flexible due to the smart design based on configurations of 6, 12 and 18 outgoing ways and to the new ABB plug-in system that allows easy and fast connections for all T1 and T3 versions. Upon request, extension boxes are available on all sides of the structure, for metering purposes too. The vertical trunking system is running behind the MCCB's layer allowing easy access to every accessory wiring (SR's, UV's, AUX contacts). The ArTu PB Panelboard, supplied as a standard with a blind door, is available with a glazed one as well.

## Annex A: Protection against short-circuit effects inside low-voltage switchboards

The Std. IEC 60439-1 specifies that ASSEMBLIES (referred to hereafter as switchboards) shall be constructed so as to be capable of withstanding the thermal and dynamic stresses resulting from short-circuit currents up to the rated values.

Furthermore, switchboards shall be protected against short-circuit currents by means of circuit-breakers, fuses or a combination of both, which may either be incorporated in the switchboard or arranged upstream.

When ordering a switchboard, the user shall specify the short-circuit conditions at the point of installation.

This chapter takes into consideration the following aspects:

- **The need, or not, to carry out a verification of the short-circuit withstand strength of the switchboard.**
- **The suitability of a switchboard for a plant as a function of the prospective short-circuit current of the plant and of the short-circuit parameters of the switchboard.**
- **The suitability of a busbar system as a function of the short-circuit current and of the protective devices.**

## Annex A: Protection against short-circuit effects inside low-voltage switchboards

### Verification of short-circuit withstand strength

The verification of the short-circuit withstand strength is dealt with in the Standard IEC 60439-1, where, in particular, the cases requiring this verification and the different types of verification are specified.

The verification of the short-circuit withstand strength is not required if the following conditions are fulfilled:

- For switchboards having a rated short-time current ( $I_{cw}$ ) or rated conditional current ( $I_k$ ) not exceeding 10 kA.
- For switchboards protected by current limiting devices having a cut-off current not exceeding 17 kA at the maximum allowable prospective short-circuit current at the terminals of the incoming circuit of the switchboard.
- For auxiliary circuits of switchboards intended to be connected to transformers whose rated power does not exceed 10 kVA for a rated secondary voltage of not less than 110 V, or 1.6 kVA for a rated secondary voltage less than 110 V, and whose short-circuit impedance is not less than 4%.
- For all the parts of switchboards (busbars, busbar supports, connections to busbars, incoming and outgoing units, switching and protective devices, etc.) which have already been subjected to type tests valid for conditions in the switchboard.

Therefore, from an engineering point of view, the need to verify the short-circuit withstand strength may be viewed as follows:

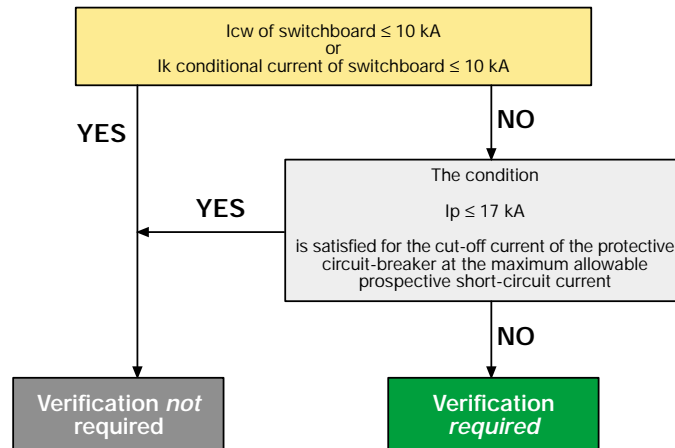

As regards the details of the test performance, reference shall be made directly to the Standard IEC 60439-1.

## Annex A: Protection against short-circuit effects inside low-voltage switchboards

### Short-circuit current and suitability of the switchboard for the plant

The verification of the short-circuit withstand strength is based on two values stated by the manufacturer in alternative to each other:

- the rated short-time current  $I_{cw}$
- the rated conditional short-circuit current  $I_k$

Based on one of these two values, it is possible to determine whether the switchboard is suitable to be installed in a particular point of the system.

***It shall be necessary to verify that the breaking capacities of the apparatus inside the switchboard are compatible with the short-circuit values of the system.***

The rated short-time withstand current  $I_{cw}$  is a predefined r.m.s. value of test current, to which a determined peak value applied to the test circuit of the switchboard for a specified time (usually 1s) corresponds. The switchboard shall be able to withstand the thermal and electro-dynamical stresses without damages or deformations which could compromise the operation of the system. From this test (if passed) it is possible to obtain the specific let-through energy ( $I^2t$ ) which can be carried by the switchboard:

$$I^2t = I_{cw}^2t$$

The test shall be carried out at a power factor value specified below in the Table 4 of the Std. IEC 60439-1. A factor "n" corresponding at this  $\cos\phi$  value allows to determine the peak value of the short-circuit current withstood by the switchboard through the following formula:

$$I_p = I_{cw} \cdot n$$

**Table 4**

r.m.s. value of short-circuit current	power factor $\cos\phi$	n
$I \leq 5$ kA	0.7	1.5
$5 < I \leq 10$ kA	0.5	1.7
$10 < I \leq 20$ kA	0.3	2
$20 < I \leq 50$ kA	0.25	2.1
$50 < I$	0.2	2.2

*The values of this table represent the majority of applications. In special locations, for example in the vicinity of transformers or generators, lower values of power factor may be found, whereby the maximum prospective peak current may become the limiting value instead of the r.m.s. value of the short-circuit current.*

The conditional short-circuit current is a predetermined r.m.s. value of test current to which a defined peak value corresponds and which can be withstood by the switchboard during the operating time of a specified protective device. This device is usually the main circuit-breaker of the switchboard.

By comparing the two values  $I_{cw}$  and  $I_p$  with the prospective short-circuit current of the plant, it is possible to establish whether the switchboard is suitable to be installed at a specified point of the system.

The following diagrams show the method to determine the compatibility of the switchboard with the plant.

## Annex A: Protection against short-circuit effects inside low-voltage switchboards

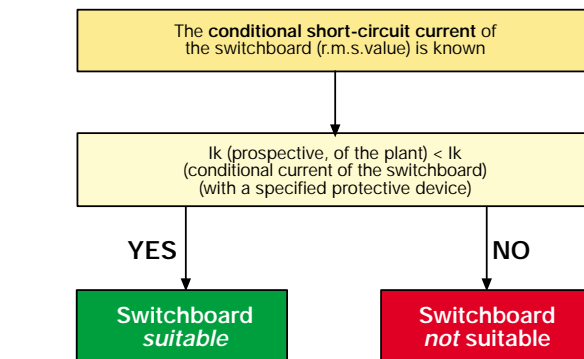
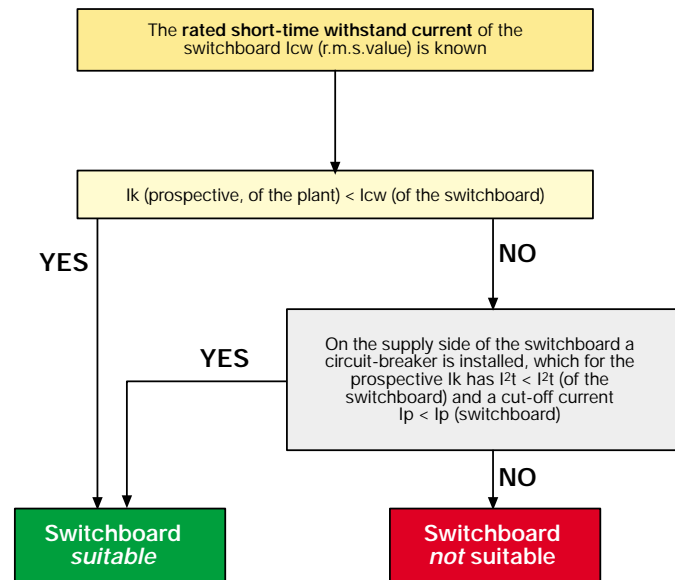

The breaking capacities of the apparatus inside the switchboard shall be verified to be compatible with the short-circuit values of the plant.

## Annex A: Protection against short-circuit effects inside low-voltage switchboards

### Example

Plant data: Rated voltage  $U_r=400\text{ V}$   
 Rated frequency  $f_r=50\text{ Hz}$   
 Short-circuit current  $I_k=35\text{ kA}$

Assume that in an existing system there is a switchboard with  $I_{cw}$  equal to 35kA and that, at the installation point of the switchboard, the prospective short-circuit current is equal to 35kA.

Now assume that an increase in the power supply of a plant is decided and that the short-circuit value rises to 60 kA.

Plant data after the increase: Rated voltage  $U_r=400\text{ V}$   
 Rated frequency  $f_r=50\text{ Hz}$   
 Short-circuit current  $I_k=60\text{ kA}$

Since the  $I_{cw}$  of the switchboard is lower than the short-circuit current of the system, in order to verify that the actual switchboard is still compatible, it is necessary to:

- determine the  $I^2t$  and  $I_p$  values let-through by the circuit-breaker on the supply side of the switchboard
- verify that the protective devices installed inside the switchboard have a sufficient breaking capacity (separately or in back-up)

$I_{cw} = 35\text{ kA}$  from which:

$$I^2t_{\text{switchboard}} = 35^2 \times 1 = 1225 \text{ MA}^2\text{s}$$

$$I_{p\text{switchboard}} = 73.5 \text{ kA (according to Table 4)}$$

Assuming that on the supply side of the switchboard a circuit-breaker type Tmax T5H (**Icu=70kA@415V**) is installed

$$I^2t_{\text{CB}} < 4\text{ MA}^2\text{s}$$

$$I_{p\text{CB}} < 40\text{ kA}$$

since

$$I^2t_{\text{switchboard}} > I^2t_{\text{CB}}$$

$$I_{p\text{switchboard}} > I_{p\text{CB}}$$

it results that the switchboard (structure and busbar system) is suitable.

Assume that the circuit-breakers installed inside the switchboard are circuit-breakers type T1, T2 and T3 version N with **Icu=36kA@415V**. From the back-up tables (see Chapter 4.3), it results that the circuit-breakers inside the switchboard are suitable for the plant, since their breaking capacity is increased to 65 kA thanks to the circuit-breaker type T5H on the supply side.

## Annex A: Protection against short-circuit effects inside low-voltage switchboards

### Selection of the distribution system in relation to short-circuit withstand strength

The dimensioning of the distribution system of the switchboard is obtained by taking into consideration the rated current flowing through it and the prospective short-circuit current of the plant.

The manufacturer usually provides tables which allow the choice of the busbar cross-section as a function of the rated current and give the mounting distances of the busbar supports to ensure the short-circuit withstand strength.

To select a distribution system compatible with the short-circuit data of the plant, one of these procedures shall be followed:

- **If the protective device on the supply side of the distribution system is known**

From the  $I_{cw}$  value of the distribution system it results:

$$I_{k_{syst}} = I_{cw} \cdot n \quad \text{where } n \text{ is the factor deduced from the Table 4}$$

$$I^2t_{syst} = I_{cw}^2 \cdot t \quad \text{where } t \text{ is equal to } 1 \text{ s}$$

In correspondence with the prospective short-circuit current value of the plant the following values can be determined:

the cut-off current of the circuit-breaker  $I_{p_{CB}}$

the specific let-through energy of the circuit-breaker  $I^2t_{CB}$

If  $I_{p_{CB}} < I_{p_{syst}}$  and  $I^2t_{CB} < I^2t_{syst}$ , then the distribution system is suitable.

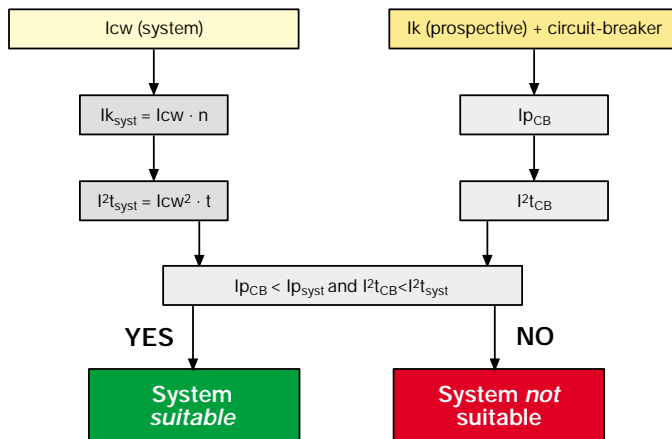

- **If the protective device on the supply side of the distribution system is not known**

The following condition must be fulfilled:

$$I_k (\text{prospective}) < I_{cw} (\text{system})$$

## Annex A: Protection against short-circuit effects inside low-voltage switchboards

### Example

Plant data: Rated voltage  $U_r=400$  V  
 Rated frequency  $f_r=50$  Hz  
 Short-circuit current  $I_k=65$  kA

By considering the need of using a system of 400 A busbars with shaped form, in the ABB SACE catalogue "ArTu distribution switchboards" the following choice is possible:

BA0400  $I_n=400$  A (IP65)  $I_{cw}=35$  kA.

By assuming to have on the supply side of the busbar system a moulded-case circuit-breaker type

ABB SACE Tmax T5400  $I_n=400$

from the  $I_{cw}$  of the busbar system, it derives:

$$I_{p_{syst}} = I_{cw} \cdot n = 35 \cdot 2.1 = 73.5 \text{ [kA]}$$

$$I^2t_{syst} = I_{cw}^2 \cdot t = 35^2 \cdot 1 = 1225 \text{ [(kA)^2s]}$$

From the curves

- at page 144

$I_k$  65kA corresponds at about  $I_{p_{CB}}=35$  kA

- at page 181

$I_k$  65kA corresponds at about  $I^2t_{CB}=4 \text{ [(kA)^2s]} = 4 \text{ [MA}^2\text{sec]}$

Thus, since

$$I_{p_{CB}} < I_{p_{syst}}$$

and

$$I^2t_{CB} < I^2t_{syst}$$

it results that the busbar system is compatible with the switchboard.

## Annex A: Protection against short-circuit effects inside low-voltage switchboards

### Selection of conductors on the supply side of the protective devices

The Standard IEC 60439-1 prescribes that in a switchboard, the active conductors (distribution busbars included) positioned between the main busbars and the supply side of the single functional units, as well as the constructional components of these units, can be dimensioned according to the reduced short-circuit stresses which occur on the load side of the short-circuit protective device of the unit.

This may be possible if the conductors are installed in such a way throughout the switchboard that, under normal operating conditions, an internal short-circuit between phases and/or between phase and earth is only a remote possibility. It is advisable that such conductors are of solid rigid manufacture.

As an example, this Standard gives conductor types and installation requirements which allow to consider a short-circuit between phases and/or between phase and earth only a remote possibility.

Type of conductor	Requirements
Bare conductors or single-core conductors with basic insulation, for example cables according to IEC 60227-3.	Mutual contact or contact with conductive parts shall be avoided, for example by use of spacers.
Single-core conductors with basic insulation and a maximum permissible conductor-operating temperature above 90°C, for example cables according to IEC 60245-3, or heat-resistant PVC insulated cables according to IEC 60227-3.	Mutual contact or contact with conductive parts is permitted where there is no applied external pressure. Contact with sharp edges must be avoided. There must be no risk of mechanical damage. These conductors may only be loaded such that an operating temperature of 70°C is not exceeded.
Conductors with basic insulation, for example cables according to IEC 60227-3, having additional secondary insulation, for example individually covered cables with shrink sleeving or individually run cables in plastic conduits.	No additional requirements if there is no risk of mechanical damage.
Conductors insulated with a very high mechanical strength material, for example FTFE insulation, or double-insulated conductors with an enhanced outer sheath rated for use up to 3 kV, for example cables according to IEC 60502.	
Single or multi-core sheathed cables, for example cables according to IEC 60245-4 or 60227-4.	

Under these conditions or if anyway the integral short-circuit may be considered a remote possibility, the above described procedure shall be used to verify the suitability of the distribution system to the short-circuit conditions, when these are determined as a function of the characteristics of the circuit-breakers on the load side of the busbars.

## Annex A: Protection against short-circuit effects inside low-voltage switchboards

### Example

Plant data:  
Rated voltage  $U_r=400$  V  
Rated frequency  $f_r=50$  Hz  
Short-circuit current  $I_k=45$  kA

In the switchboard shown in the figure, the vertical distribution busbars are derived from the main busbars. These are 800 A busbars with shaped section and with the following characteristics:  
In (IP65) = 800 A,  
 $I_{cw\ max} = 35$  kA  
Since it is a "rigid" system with spacers, according to the Std. IEC 60439-1 a short-circuit between busbars is a remote possibility.

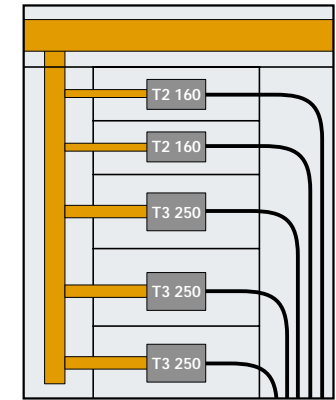

Anyway, a verification that the stresses reduced by the circuit-breakers on the load side of the system are compatible with the system is required. Assuming that in the cubicles there are the following circuit-breakers:

ABB SACE T3S250  
ABB SACE T2S160

it is necessary to verify that, in the case of a short-circuit on any outgoing conductor, the limitations created by the circuit-breaker are compatible with the busbar system; to comply with this requirement, at the maximum allowable prospective short-circuit current, the circuit-breaker with higher cut-off current and let-through energy must have an adequate current limiting capability for the busbar system.

In this case the circuit-breaker is type ABB SACE T3S250 In250. The verification shall be carried out as in the previous paragraph:

From the  $I_{cw}$  of the busbar system, it derives:

$$I_{p\ syst} = I_{cw} \cdot n = 35 \cdot 2.1 = 73.5 \quad [\text{kA}]$$

$$I^2 t_{syst} = I_{cw}^2 \cdot t = 35^2 \cdot 1 = 1225 \quad [(\text{kA})^2 \text{s}]$$

From the limitation and let-through energy curves

- at page 142  
 $I_k = 45$  kA corresponds at about  $I_{pCB} = 30$  kA
- at page 179  
 $I_k = 45$  kA corresponds at about  $I^2 t_{CB} = 2$  [(kA)<sup>2</sup>s]

Thus, since

$$I_{pCB} < I_{p\ syst}$$

$$\text{and}$$

$$I^2 t_{CB} < I^2 t_{syst}$$

it results that the busbar system is compatible with the switchboard.

## Annex B: Temperature rise evaluation according to IEC 60890

The calculation method suggested in the Standard IEC 60890 makes it possible to evaluate the temperature rise inside an assembly (PTTA); this method is applicable only if the following conditions are met:

- there is an approximately even distribution of power losses inside the enclosure;
- the installed equipment is arranged in a way that air circulation is only slightly impeded;
- the equipment installed is designed for direct current or alternating current up to and including 60 Hz with the total of supply currents not exceeding 3150 A;
- conductors carrying high currents and structural parts are arranged in a way that eddy-current losses are negligible;
- for enclosures with ventilating openings, the cross-section of the air outlet openings is at least 1.1 times the cross-section of the air inlet openings;
- there are no more than three horizontal partitions in the PTTA or a section of it;
- where enclosures with external ventilation openings have compartments, the surface of the ventilation openings in each horizontal partition shall be at least 50% of the horizontal cross section of the compartment.

The data necessary for the calculation are:

- dimensions of the enclosure: height, width, depth;
- the type of installation of the enclosure (see Table 8);
- presence of ventilation openings;
- number of internal horizontal partitions;
- the power loss of the equipment installed in the enclosure (see Tables 13 and 14);
- the power loss of the conductors inside the enclosure, equal to the sum of the power loss of every conductor, according to Tables 1, 2 and 3.

For equipment and conductors not fully loaded, it is possible to evaluate the power loss as:

$$P = P_n \left( \frac{I_b}{I_n} \right)^2 \quad (1)$$

where:

- P is the actual power loss;
- P<sub>n</sub> is the rated power loss (at I<sub>n</sub>);
- I<sub>b</sub> is the actual current;
- I<sub>n</sub> is the rated current.

## Annex B: Temperature rise evaluation according to IEC 60890

Table 1: Operating current and power losses of insulated conductors

Cross-section (Cu)	Maximum permissible conductor temperature 70 °C											
	Air temperature inside the enclosure around the conductors											
	35 °C		55 °C		35 °C		55 °C		35 °C		55 °C	
	operating current	power losses 2)	operating current	power losses 2)	operating current	power losses 2)	operating current	power losses 2)	operating current	power losses 2)	operating current	power losses 2)
mm <sup>2</sup>	A	W/m	A	W/m	A	W/m	A	W/m	A	W/m	A	W/m
1.5	12	2.1	8	0.9	12	2.1	8	0.9	12	2.1	8	0.9
2.5	17	2.5	11	1.1	20	3.5	12	1.3	20	3.5	12	1.3
4	22	2.6	14	1.1	25	3.4	18	1.8	25	3.4	20	2.2
6	28	2.8	18	1.2	32	3.7	23	1.9	32	3.7	25	2.3
10	38	3.0	25	1.3	48	4.8	31	2.0	50	5.2	32	2.1
16	52	3.7	34	1.6	64	5.6	42	2.4	65	5.8	50	3.4
25					85	6.3	55	2.6	85	6.3	65	3.7
35					104	7.5	67	3.1	115	7.9	85	5.0
50					130	7.9	85	3.4	150	10.5	115	6.2
70					161	8.4	105	3.6	175	9.9	149	7.2
95					192	8.7	125	3.7	225	11.9	175	7.2
120					226	9.6	147	4.1	250	11.7	210	8.3
150					275	11.7	167	4.3	275	11.7	239	8.8
185					295	10.9	191	4.6	350	15.4	273	9.4
240					347	12.0	225	5.0	400	15.9	322	10.3
300					400	13.2	260	5.6	460	17.5	371	11.4

Conductors for auxiliary circuits					
					Diam.
0.12	2.6	1.2	1.7	0.5	0.4
0.14	2.9	1.3	1.9	0.6	-
0.20	3.2	1.1	2.1	0.5	-
0.22	3.6	1.3	2.3	0.5	0.5
0.30	4.4	1.4	2.9	0.6	0.6
0.34	4.7	1.4	3.1	0.6	0.6
0.50	6.4	1.8	4.2	0.8	0.8
0.56		1.6		0.7	-
0.75	8.2	1.9	5.4	0.8	1.0
1.00	9.3	1.8	6.1	0.8	-

1) Any arrangement desired with the values specified referring to six cores in a multi-core bundle with a simultaneous load 100%

2) single length

### Annex B: Temperature rise evaluation according to IEC 60890

Table 2: Operating current and power losses of bare conductors, in vertical arrangement without direct connections to apparatus

Width x Thickness	Cross-section (Cu)	Maximum permissible conductor temperature 85 °C															
		Air temperature inside the enclosure around the conductors 35 °C								Air temperature inside the enclosure around the conductors 55 °C							
		50 Hz to 60 Hz ac				dc and ac to 16 2/3 Hz				50 Hz to 60 Hz ac				dc and ac to 16 2/3 Hz			
		operating current	power losses 1)	operating current	power losses 1)	operating current	power losses 1)	operating current	power losses 1)	operating current	power losses 1)	operating current	power losses 1)	operating current	power losses 1)	operating current	power losses 1)
mm x mm	mm <sup>2</sup>	A*	W/m	A**	W/m	A*	W/m	A**	W/m	A*	W/m	A**	W/m	A*	W/m	A**	W/m
12 x 2	23.5	144	19.5	242	27.5	144	19.5	242	27.5	105	10.4	177	14.7	105	10.4	177	14.7
15 x 2	29.5	170	21.7	282	29.9	170	21.7	282	29.9	124	11.6	206	16.0	124	11.6	206	16.0
15 x 3	44.5	215	23.1	375	35.2	215	23.1	375	35.2	157	12.3	274	18.8	157	12.3	274	18.8
20 x 2	39.5	215	26.1	351	34.8	215	26.1	354	35.4	157	13.9	256	18.5	157	12.3	258	18.8
20 x 3	59.5	271	27.6	463	40.2	271	27.6	463	40.2	198	14.7	338	21.4	198	14.7	338	21.4
20 x 5	99.1	364	29.9	665	49.8	364	29.9	668	50.3	266	16.0	485	26.5	266	16.0	487	26.7
20 x 10	199	568	36.9	1097	69.2	569	36.7	1107	69.6	414	19.6	800	36.8	415	19.5	807	37.0
25 x 5	124	435	34.1	779	55.4	435	34.1	78	55.6	317	18.1	568	29.5	317	18.1	572	29.5
30 x 5	149	504	38.4	894	60.6	505	38.2	899	60.7	368	20.5	652	32.3	369	20.4	656	32.3
30 x 10	299	762	44.4	1410	77.9	770	44.8	1436	77.8	556	27.7	1028	41.4	562	23.9	1048	41.5
40 x 5	199	641	47.0	1112	72.5	644	47.0	1128	72.3	468	25.0	811	38.5	469	24.9	586	38.5
40 x 10	399	951	52.7	1716	88.9	968	52.6	1796	90.5	694	28.1	1251	47.3	706	28.0	1310	48.1
50 x 5	249	775	55.7	1322	82.9	782	55.4	1357	83.4	566	29.7	964	44.1	570	29.4	989	44.3
50 x 10	499	1133	60.9	2008	102.9	1164	61.4	2141	103.8	826	32.3	1465	54.8	849	32.7	1562	55.3
60 x 5	299	915	64.1	1530	94.2	926	64.7	1583	94.6	667	34.1	1116	50.1	675	34.4	1154	50.3
60 x 10	599	1310	68.5	2288	116.2	1357	69.5	2487	117.8	955	36.4	1668	62.0	989	36.9	1814	62.7
80 x 5	399	1170	80.7	1929	116.4	1200	80.8	2035	116.1	858	42.9	1407	61.9	875	42.9	1484	61.8
80 x 10	799	1649	85.0	2806	138.7	1742	85.1	3165	140.4	1203	45.3	2047	73.8	1271	45.3	1756	74.8
100 x 5	499	1436	100.1	2301	137.0	1476	98.7	2407	121.2	1048	53.3	1678	72.9	1077	52.5	1756	69.8
100 x 10	999	1982	101.7	3298	164.2	2128	102.6	3844	169.9	1445	54.0	2406	84.4	1552	54.6	2803	90.4
120 x 10	1200	2314	115.5	3804	187.3	2514	115.9	4509	189.9	1688	61.5	2774	99.6	1833	61.6	3288	101.0

\*) one conductor per phase    \*\*) two conductors per phase    1) single length

1SDCC08041F0201

### Annex B: Temperature rise evaluation according to IEC 60890

Table 3: Operating current and power losses of bare conductors used as connections between apparatus and busbars

Width x Thickness	Cross-section (Cu)	Maximum permissible conductor temperature 65 °C							
		Air temperature inside the enclosure around the conductors 35 °C				Air temperature inside the enclosure around the conductors 55 °C			
		50 Hz to 60 Hz ac and dc							
		operating current	power losses 1)	operating current	power losses 1)	operating current	power losses 1)	operating current	power losses 1)
mm x mm	mm <sup>2</sup>	A*	W/m	A**	W/m	A*	W/m	A**	W/m
12 x 2	23.5	82	5.9	130	7.4	69	4.2	105	4.9
15 x 2	29.5	96	6.4	150	7.8	88	5.4	124	5.4
15 x 3	44.5	124	7.1	202	9.5	102	4.8	162	6.1
20 x 2	39.5	115	6.9	184	8.9	93	4.5	172	7.7
20 x 3	59.5	152	8.0	249	10.8	125	5.4	198	6.8
20 x 5	99.1	218	9.9	348	12.7	174	6.3	284	8.4
20 x 10	199	348	12.8	648	22.3	284	8.6	532	15.0
25 x 5	124	253	10.7	413	14.2	204	7.0	338	9.5
30 x 5	149	288	11.6	492	16.9	233	7.6	402	11.3
30 x 10	299	482	17.2	960	32.7	402	11.5	780	21.6
40 x 5	199	348	12.8	648	22.3	284	8.6	532	15.0
40 x 10	399	648	22.7	1245	41.9	532	15.3	1032	28.8
50 x 5	249	413	14.7	805	27.9	338	9.8	655	18.5
50 x 10	499	805	28.5	1560	53.5	660	19.2	1280	36.0
60 x 5	299	492	17.2	960	32.7	402	11.5	780	21.6
60 x 10	599	960	34.1	1848	63.2	780	22.5	1524	43.0
80 x 5	399	648	22.7	1256	42.6	532	15.3	1032	28.8
80 x 10	799	1256	45.8	2432	85.8	1032	30.9	1920	53.5
100 x 5	499	805	29.2	1560	54.8	660	19.6	1280	36.9
100 x 10	999	1560	58.4	2680	86.2	1280	39.3	2180	57.0
120 x 10	1200	1848	68.3	2928	85.7	1524	46.5	2400	57.6

\*) one conductor per phase    \*\*) two conductors per phase    1) single length

1SDCC08042F0201



## Annex B: Temperature rise evaluation according to IEC 60890

Where enclosures without vertical partitions or individual sections have an effective cooling surface greater than about 11.5 m or a width greater than about 1.5 m, they should be divided for the calculation into fictitious sections, whose dimensions approximate to the foregoing values.

The following diagram shows the procedure to evaluate the temperature rise.

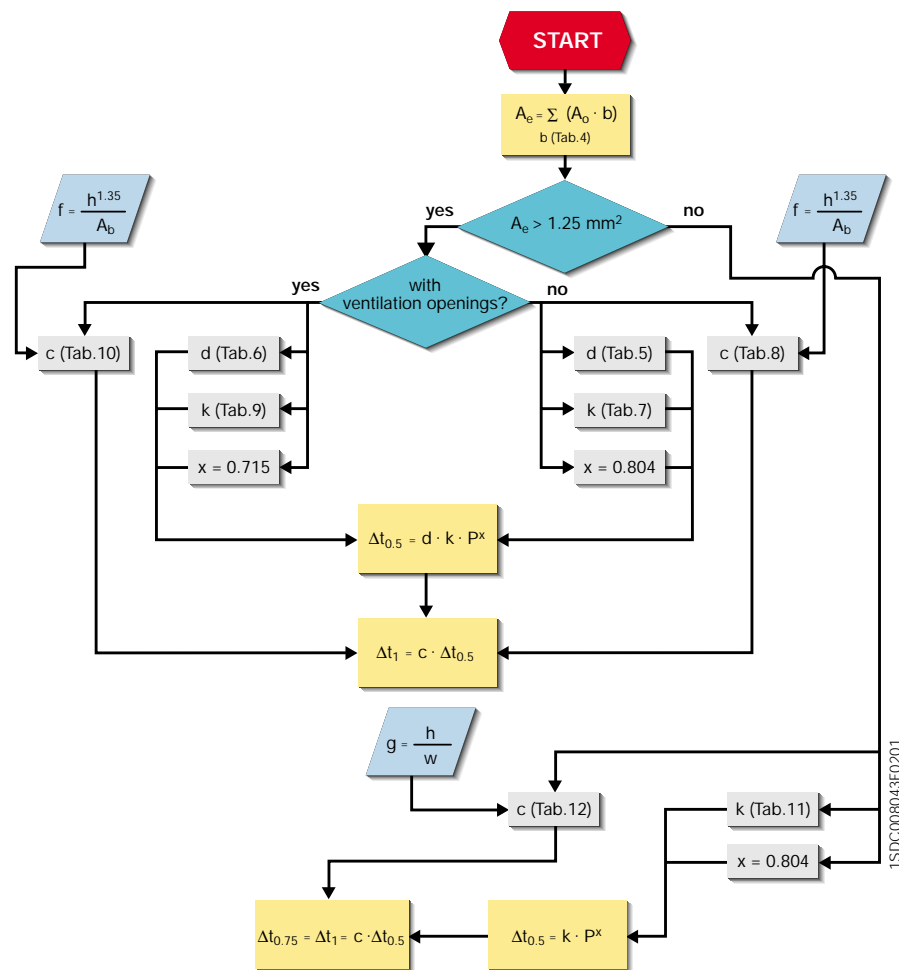

## Annex B: Temperature rise evaluation according to IEC 60890

Table 4: Surface factor *b* according to the type of installation

Type of installation	Surface factor <i>b</i>
Exposed top surface	1.4
Covered top surface, e.g. of built-in enclosures	0.7
Exposed side faces, e.g. front, rear and side walls	0.9
Covered side faces, e.g. rear side of wall-mounted enclosures	0.5
Side faces of central enclosures	0.5
Floor surface	Not taken into account

Fictitious side faces of sections which have been introduced only for calculation purposes are not taken into account

Table 5: Factor *d* for enclosures without ventilation openings and with an effective cooling surface *A<sub>e</sub>* > 1.25 m<sup>2</sup>

Number of horizontal partitions <i>n</i>	Factor <i>d</i>
0	1
1	1.05
2	1.15
3	1.3

Table 6: Factor *d* for enclosures with ventilation openings and with an effective cooling surface *A<sub>e</sub>* > 1.25 m<sup>2</sup>

Number of horizontal partitions <i>n</i>	Factor <i>d</i>
0	1
1	1.05
2	1.1
3	1.15

Table 7: Enclosure constant *k* for enclosures without ventilation openings, with an effective cooling surface *A<sub>e</sub>* > 1.25 m<sup>2</sup>

<i>A<sub>e</sub></i> [m <sup>2</sup> ]	<i>k</i>	<i>A<sub>e</sub></i> [m <sup>2</sup> ]	<i>k</i>
1.25	0.524	6.5	0.135
1.5	0.45	7	0.13
2	0.35	7.5	0.125
2.5	0.275	8	0.12
3	0.225	8.5	0.115
3.5	0.2	9	0.11
4	0.185	9.5	0.105
4.5	0.17	10	0.1
5	0.16	10.5	0.095
5.5	0.15	11	0.09
6	0.14	11.5	0.085







## Annex B: Temperature rise evaluation according to IEC 60890

Table 8: Temperature distribution factor *c* for enclosures without ventilation openings, with an effective cooling surface  $A_e > 1.25 \text{ m}^2$

$$f = \frac{h^{1.35}}{A_b}$$

$f = \frac{h^{1.35}}{A_b}$	Type of installation				
	1	2	3	4	5
0.6	1.225	1.21	1.19	1.17	1.113
1	1.24	1.225	1.21	1.185	1.14
1.5	1.265	1.245	1.23	1.21	1.17
2	1.285	1.27	1.25	1.23	1.19
2.5	1.31	1.29	1.275	1.25	1.21
3	1.325	1.31	1.295	1.27	1.23
3.5	1.35	1.33	1.315	1.29	1.255
4	1.37	1.355	1.34	1.32	1.275
4.5	1.395	1.375	1.36	1.34	1.295
5	1.415	1.395	1.38	1.36	1.32
5.5	1.435	1.415	1.4	1.38	1.34
6	1.45	1.435	1.42	1.395	1.355
6.5	1.47	1.45	1.435	1.41	1.37
7	1.48	1.47	1.45	1.43	1.39
7.5	1.495	1.48	1.465	1.44	1.4
8	1.51	1.49	1.475	1.455	1.415
8.5	1.52	1.505	1.49	1.47	1.43
9	1.535	1.52	1.5	1.48	1.44
9.5	1.55	1.53	1.515	1.49	1.455
10	1.56	1.54	1.52	1.5	1.47
10.5	1.57	1.55	1.535	1.51	1.475
11	1.575	1.565	1.549	1.52	1.485
11.5	1.585	1.57	1.55	1.525	1.49
12	1.59	1.58	1.56	1.535	1.5
12.5	1.6	1.585	1.57	1.54	1.51

where *h* is the height of the enclosure, and  $A_b$  is the area of the base.  
For "Type of installation":

	Type of installation n°	
1	Separate enclosure, detached on all sides	
2	First or last enclosure, detached type	
3	Separate enclosure for wall-mounting	
	Central enclosure, detached type	
4	First or last enclosure, wall-mounting type	
	Central enclosure for wall-mounting and with covered top surface	
5	Central enclosure, wall-mounting type	

1SDC008069F0001

## Annex B: Temperature rise evaluation according to IEC 60890

Table 9: Enclosure constant *k* for enclosures with ventilation openings and an effective cooling surface  $A_e > 1.25 \text{ m}^2$

Ventilation opening in $\text{cm}^2$	$A_e \text{ [m}^2\text{]}$													
	1	1.5	2	2.5	3	4	5	6	7	8	10	12	14	
50	0.36	0.33	0.3	0.28	0.26	0.24	0.22	0.208	0.194	0.18	0.165	0.145	0.135	
100	0.293	0.27	0.25	0.233	0.22	0.203	0.187	0.175	0.165	0.153	0.14	0.128	0.119	
150	0.247	0.227	0.21	0.198	0.187	0.173	0.16	0.15	0.143	0.135	0.123	0.114	0.107	
200	0.213	0.196	0.184	0.174	0.164	0.152	0.143	0.135	0.127	0.12	0.11	0.103	0.097	
250	0.19	0.175	0.165	0.155	0.147	0.138	0.13	0.121	0.116	0.11	0.1	0.095	0.09	
300	0.17	0.157	0.148	0.14	0.133	0.125	0.118	0.115	0.106	0.1	0.093	0.088	0.084	
350	0.152	0.141	0.135	0.128	0.121	0.115	0.109	0.103	0.098	0.093	0.087	0.082	0.079	
400	0.138	0.129	0.121	0.117	0.11	0.106	0.1	0.096	0.091	0.088	0.081	0.078	0.075	
450	0.126	0.119	0.111	0.108	0.103	0.099	0.094	0.09	0.086	0.083	0.078	0.074	0.07	
500	0.116	0.11	0.104	0.1	0.096	0.092	0.088	0.085	0.082	0.078	0.073	0.07	0.067	
550	0.107	0.102	0.097	0.093	0.09	0.087	0.083	0.08	0.078	0.075	0.07	0.068	0.065	
600	0.1	0.095	0.09	0.088	0.085	0.082	0.079	0.076	0.073	0.07	0.067	0.065	0.063	
650	0.094	0.09	0.086	0.083	0.08	0.077	0.075	0.072	0.07	0.068	0.065	0.063	0.061	
700	0.089	0.085	0.08	0.078	0.076	0.074	0.072	0.07	0.068	0.066	0.064	0.062	0.06	

Table 10: Temperature distribution factor *c* for enclosures with ventilation openings and an effective cooling surface  $A_e > 1.25 \text{ m}^2$

$$f = \frac{h^{1.35}}{A_b}$$

Ventilation opening in $\text{cm}^2$	$f = \frac{h^{1.35}}{A_b}$									
	1.5	2	3	4	5	6	7	8	9	10
50	1.3	1.35	1.43	1.5	1.57	1.63	1.68	1.74	1.78	1.83
100	1.41	1.46	1.55	1.62	1.68	1.74	1.79	1.84	1.88	1.92
150	1.5	1.55	1.63	1.69	1.75	1.8	1.85	1.9	1.94	1.97
200	1.56	1.61	1.67	1.75	1.8	1.85	1.9	1.94	1.97	2.01
250	1.61	1.65	1.73	1.78	1.84	1.88	1.93	1.97	2.01	2.04
300	1.65	1.69	1.75	1.82	1.86	1.92	1.96	2	2.03	2.06
350	1.68	1.72	1.78	1.85	1.9	1.94	1.97	2.02	2.05	2.08
400	1.71	1.75	1.81	1.87	1.92	1.96	2	2.04	2.07	2.1
450	1.74	1.77	1.83	1.88	1.94	1.97	2.02	2.05	2.08	2.12
500	1.76	1.79	1.85	1.9	1.95	1.99	2.04	2.06	2.1	2.13
550	1.77	1.82	1.88	1.93	1.97	2.01	2.05	2.08	2.11	2.14
600	1.8	1.83	1.88	1.94	1.98	2.02	2.06	2.09	2.12	2.15
650	1.81	1.85	1.9	1.95	1.99	2.04	2.07	2.1	2.14	2.17
700	1.83	1.87	1.92	1.96	2	2.05	2.08	2.12	2.15	2.18

## Annex B: Temperature rise evaluation according to IEC 60890

Table 11: Enclosure constant  $k$  for enclosures without ventilation openings and with an effective cooling surface  $A_e \leq 1.25 \text{ m}^2$

$A_e \text{ [m}^2\text{]}$	$k$	$A_e \text{ [m}^2\text{]}$	$k$
0.08	3.973	0.65	0.848
0.09	3.643	0.7	0.803
0.1	3.371	0.75	0.764
0.15	2.5	0.8	0.728
0.2	2.022	0.85	0.696
0.25	1.716	0.9	0.668
0.3	1.5	0.95	0.641
0.35	1.339	1	0.618
0.4	1.213	1.05	0.596
0.45	1.113	1.1	0.576
0.5	1.029	1.15	0.557
0.55	0.960	1.2	0.540
0.6	0.9	1.25	0.524

Table 12: Temperature distribution factor  $c$  for enclosures without ventilation openings and with an effective cooling surface  $A_e \leq 1.25 \text{ m}^2$

$g$	$c$	$g$	$c$
0	1	1.5	1.231
0.1	1.02	1.6	1.237
0.2	1.04	1.7	1.24
0.3	1.06	1.8	1.244
0.4	1.078	1.9	1.246
0.5	1.097	2	1.249
0.6	1.118	2.1	1.251
0.7	1.137	2.2	1.253
0.8	1.156	2.3	1.254
0.9	1.174	2.4	1.255
1	1.188	2.5	1.256
1.1	1.2	2.6	1.257
1.2	1.21	2.7	1.258
1.3	1.22	2.8	1.259
1.4	1.226		

where  $g$  is the ratio of the height and the width of the enclosure.

## Annex B: Temperature rise evaluation according to IEC 60890

Total (3/4 poles) power loss in W

Releases	ln[A]	T11P		T2		T3		T4		T5		T6		T7 S,H,L		T7 V		S7	
		F	F	F	P	F	P	F	P/W	F	P/W	F	W	F	W	F	W	F	W
	1			4.5	5.1														
	1.6			6.3	7.5														
	2			7.5	8.7														
	2.5			7.8	9														
	3.2			8.7	10.2														
	4			7.8	9														
	5			8.7	10.5														
	6.3			10.5	12.3														
	8			8.1	9.6														
	10			9.3	10.8														
	12.5			3.3	3.9														
	16	1.5	4.5	4.2	4.8														
TMF	20	1.8	5.4	5.1	6			10.8	10.8										
TMD	25	2	6	6.9	8.4														
TMA	32	2.1	6.3	8.1	9.6			11.1	11.1										
MF	40	2.6	7.8	11.7	13.8														
MA	50	3.7	11.1	12.9	15			11.7	12.3										
	63	4.3	12.9	15.3	18	12.9	15.3												
	80	4.8	14.4	18.3	21.6	14.4	17.4	13.8	15										
	100	7	21	25.5	30	16.8	20.4	15.6	17.4										
	125	10.7	32.1	36	44.1	19.8	23.7	18.6	21.6										
	160	15	45	51	60	23.7	28.5	22.2	27										
	200					39.6	47.4	29.7	37.2										
	250					53.4	64.2	41.1	52.8										
	320								40.8	62.7									
	400								58.5	93									
	500								86.4	110.1									
	630										92	117							
	800										93	119							
	10			1.5	1.8														
	25			3	3.6														
	63			10.5	12														
	100			24	27.6			5.1	6.9										
	160			51	60			13.2	18										
PR21...	250							32.1	43.8										
PR22...	320							52.8	72	31.8	53.7								
PR33...	400							49.5	84			15	27	24	36				
	630							123	160.8	90	115	36	66	60	90				
	800									96	125	57.9	105.9	96	144				
	1000									150		90	165	150	225	102	140		
	1250											141	258	234.9	351.9	160	220		
	1600												231	423			260	360	
	2000																		
	2500																		
	3200																		

The values indicated in the table refer to balanced loads, with a current flow equal to the ln, and are valid for both circuit-breakers and switch-disconnectors, three-pole and four-pole versions. For the latter, the current of the neutral is nil by definition.

## Annex B: Temperature rise evaluation according to IEC 60890

Table 14: Emax power losses

Total (3/4 poles) power loss in W	X1-BN		X1-L		E1B-N		E2B-N-S		E2L		E3N-S-H-V		E3L		E4S-H-V		E6H-V		
	F	W	F	W	F	W	F	W	F	W	F	W	F	W	F	W	F	W	
In=630	31	60	61	90															
In=800	51	104	99	145	65	95	29	53			22	36							
In=1000	79	162	155	227	96	147	45	83			38	58							
In=1250	124	293	242	354	150	230	70	130	105	165	60	90							
In=1600	209	415			253	378	115	215	170	265	85	150							
In=2000							180	330			130	225	215	330					
In=2500											205	350	335	515					
In=3200											330	570			235	425	170	290	
In=4000															360	660	265	445	
In=5000																	415	700	
In=6300																		650	1100

### Example

Hereunder an example of temperature rise evaluation for a switchboard with the following characteristics:

- enclosure without ventilation openings
- no internal segregation
- separate enclosure for wall-mounting
- one main circuit-breaker
- 5 circuit-breakers for load supply
- busbars and cable systems

Enclosure

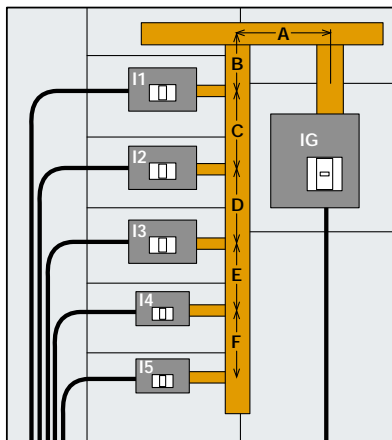

Circuit diagram

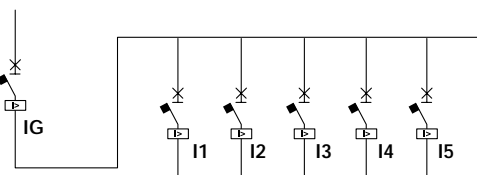

Dimensions [mm]			Number of horizontal partitions = 0
Height	Width	Depth	
2000	1440	840	Separate enclosure for wall-mounting

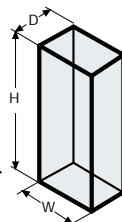

## Annex B: Temperature rise evaluation according to IEC 60890

The power losses from each component of the above switchboard are evaluated hereunder.

For the circuit-breakers, the power losses are calculated as  $P = P_n \left(\frac{I_b}{I_n}\right)^2$ , with  $I_n$  and  $P_n$  given in the Tables 14 and 15.

The table below shows the values relevant to each circuit-breaker of the switchboard in question:

Circuit-breakers	In CB [A]	Ib [A]	Power losses [W]	
IG	E2 1600 EL	1600	1340	80.7
I1	T5 400 EL	400	330	33.7
I2	T5 400 EL	400	330	33.7
I3	T5 400 EL	400	330	33.7
I4	T3 250 TMD	250	175	26.2
I5	T3 250 TMD	250	175	26.2
<b>Total power loss of circuit-breakers [W]</b>			<b>234</b>	

For the busbars, the power losses are calculated as  $P = P_n \left(\frac{I_b}{I_n}\right)^2 \cdot (3 \cdot \text{Length})$  with  $I_n$  and  $P_n$  given in the Table 2.

The table below shows the power losses of busbars:

Busbars	Cross-section nx[mm]x[mm]	Length [m]	Ib [A]	Power losses [W]
A	2x60x10	0.393	1340	47.2
B	80x10	0.332	1340	56
C	80x10	0.300	1010	28.7
D	80x10	0.300	680	13
E	80x10	0.300	350	3.5
F	80x10	0.300	175	0.9
<b>Total power loss of busbars [W]</b>				<b>149</b>

For the bare conductors connecting the busbars to the circuit-breakers, the power losses are calculated as  $P = P_n \left(\frac{I_b}{I_n}\right)^2 \cdot (3 \cdot \text{Length})$ , with  $I_n$  and  $P_n$  given in the Table 2. Here below the values for each section:

Connection bare conductors	Cross-section nx[mm]x[mm]	Length [m]	Ib [A]	Power losses [W]
Ig	2x60x10	0.450	1340	54
I1	30x10	0.150	330	3.8
I2	30x10	0.150	330	3.8
I3	30x10	0.150	330	3.8
I4	20x10	0.150	175	1.6
I5	20x10	0.150	175	1.6
<b>Total power loss of bare conductors [W]</b>				<b>68</b>

## Annex B: Temperature rise evaluation according to IEC 60890

For the cables connecting the circuit-breakers to the supply and the loads, the power losses are calculated as  $P = P_n \left( \frac{I_b}{I_n} \right)^2 \cdot (3 \cdot \text{Length})$ , with  $I_n$  and  $P_n$  given in the Table 4.

Here below the power losses for each connection:

Cables	Cross-section [n]xmm <sup>2</sup>	Length [m]	I <sub>b</sub> [A]	Power losses [W]
I <sub>G</sub>	4x240	1.0	1340	133.8
I <sub>1</sub>	240	2.0	330	64.9
I <sub>2</sub>	240	1.7	330	55.2
I <sub>3</sub>	240	1.4	330	45.4
I <sub>4</sub>	120	1.1	175	19
I <sub>5</sub>	120	0.8	175	13.8
<b>Total power loss of cables [W]</b>				<b>332</b>

Thus, the total power loss inside the enclosure is: **P = 784 [W]**

From the geometrical dimensions of the switchboard, the effective cooling surface  $A_e$  is determined below:

	Dimensions[m]x[m]	A <sub>0</sub> [m <sup>2</sup> ]	b factor	A <sub>0</sub>
Top	0.840x1.44	1.21	1.4	1.69
Front	2x1.44	1.64	0.9	2.59
Rear	2x1.44	1.64	0.5	1.44
Left-hand side	2x0.840	1.68	0.9	1.51
Right-hand side	2x0.840	1.68	0.9	1.51
<b>A<sub>e</sub>=Σ(A<sub>0</sub>·b)</b>				<b>8.75</b>

Making reference to the procedure described in the diagram at page 348, it is possible to evaluate the temperature rise inside the switchboard.

## Annex B: Temperature rise evaluation according to IEC 60890

From Table 7,  $k$  results 0.112 (value interpolated)

Since  $x = 0.804$ , the temperature rise at half the height of the enclosure is:

$$\Delta t_{0.5} = d \cdot k \cdot P^x = 1 \cdot 0.112 \cdot 784^{0.804} = 23.8 \text{ K}$$

For the evaluation of the temperature rise at the top of the enclosure, it is necessary to determine the  $c$  factor by using the  $f$  factor:

$$f = \frac{h^{1.35}}{A_b} = \frac{21.35}{1.44 \cdot 0.84} = 2.107 \quad (A_b \text{ is the base area of the switchboard})$$

From Table 8, column 3 (separate enclosure for wall-mounting),  $c$  results to be equal to 1.255 (value interpolated).

$$\Delta t_1 = c \cdot \Delta t_{0.5} = 1.255 \cdot 23.8 = 29.8 \text{ K}$$

Considering 35°C ambient temperature, as prescribed by the Standard, the following temperatures shall be reached inside the enclosure:

$$t_{0.5} = 35 + 23.8 \approx 59^\circ\text{C}$$

$$t_1 = 35 + 29.8 \approx 65^\circ\text{C}$$

Assuming that the temperature derating of the circuit-breakers inside the switchboard can be compared to the derating at an ambient temperature different from 40°C, through the tables of Chapter 3.5, it is possible to verify if the selected circuit-breakers can carry the required currents:

$$E2 \text{ 1600 at } 65^\circ\text{C} \quad I_n=1538[\text{A}] > I_g = 1340 [\text{A}]$$

$$T5 \text{ 400 at } 65^\circ\text{C} \quad I_n=384 [\text{A}] > I_1 = I_2 = I_3 = 330 [\text{A}]$$

$$T3 \text{ 250 at } 60^\circ\text{C} \quad I_n=216 [\text{A}] > I_4 = I_5 = 175 [\text{A}]$$

## Annex C: Application examples Advanced protection functions with PR123/P and PR333/P releases

### Dual Setting

Thanks to the new PR123 and PR333 releases, it is possible to program two different sets of parameters and, through an external command, to switch from one set to the other.

This function is useful when there is an emergency source (generator) in the system, only supplying voltage in the case of a power loss on the network side.

#### Example:

In the system described below, in the case of a loss of the normal supply on the network side, by means of ABB SACE ATS010 automatic transfer switch, it is possible to switch the supply from the network to the emergency power unit and to disconnect the non-priority loads by opening the QS1 switch-disconnector.

Under normal service conditions of the installation, the circuit-breakers C are set in order to be selective with both circuit-breaker A, on the supply side, as well as with circuit-breakers D on the load side.

By switching from the network to the emergency power unit, circuit-breaker B becomes the reference circuit-breaker on the supply side of circuit-breakers C. This circuit-breaker, being the protection of a generator, must be set to trip times shorter than A and therefore the setting values of the circuit-breakers on the load side might not guarantee the selectivity with B.

By means of the "dual setting" function of the PR123 and PR 333 releases, it is possible to switch circuit-breakers C from a parameter set which guarantees selectivity with A, to another set which make them selective with B.

However, these new settings could make the combination between circuit-breakers C and the circuit-breakers on the load side non-selective.



ABB SACE - Protection and control devices

## Annex C: Application examples Advanced protection functions with PR123/P and PR333/P releases

The figure at the side shows the time-current curves of the installation under normal service conditions. The values set allow no intersection of the curves.

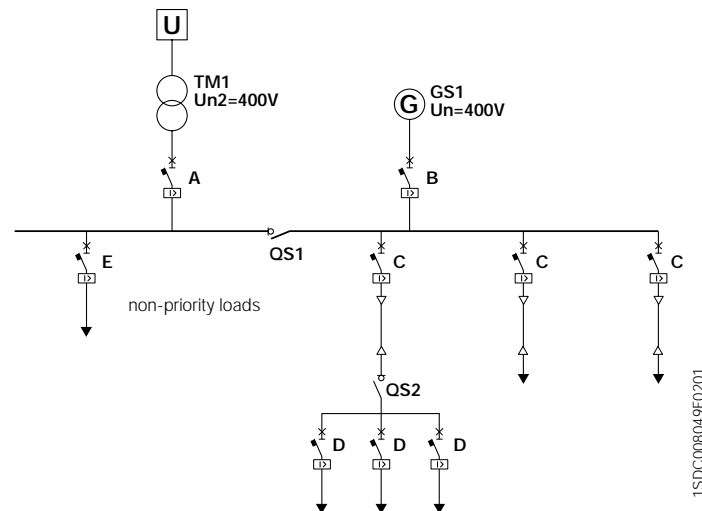
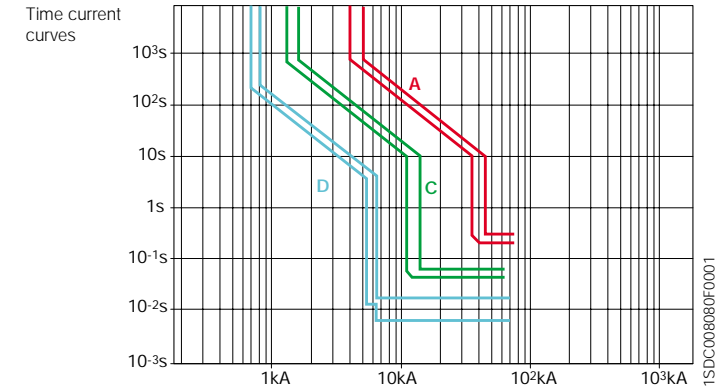

The figure at the side shows the situation in which, after switching, the power is supplied by the power unit through circuit-breaker B. If the settings of circuit-breakers C are not modified, there will be no selectivity with the main circuit-breaker B.

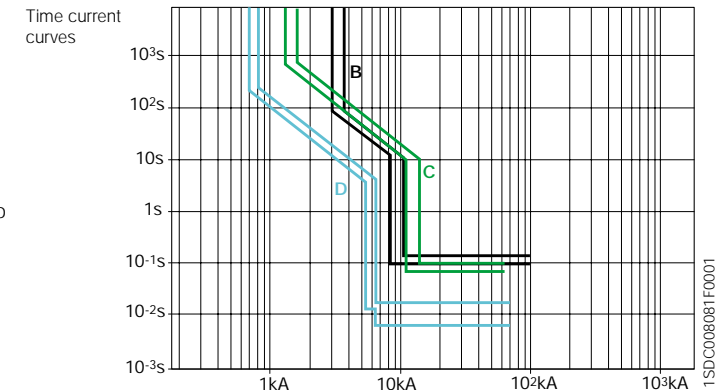

This last figure shows how it is possible to switch to a set of parameters which guarantees selectivity of circuit-breakers C with B by means of the "dual setting" function.



ABB SACE - Protection and control devices

## Annex C: Application examples

### Advanced protection functions with PR123/P and PR333/P releases

#### Double G

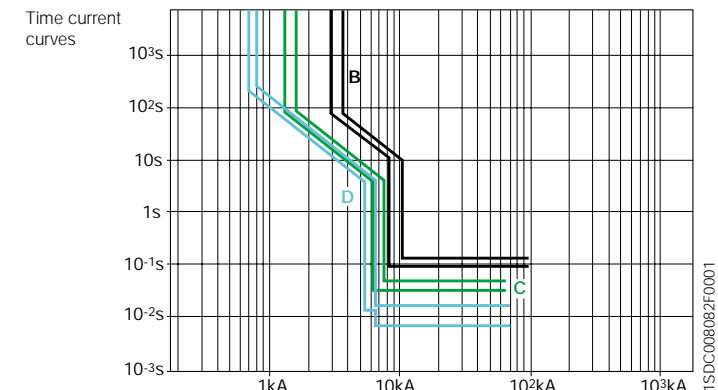
The Emax type circuit-breakers, equipped with the PR123 and PR333 electronic releases, allow two independent curves for protection G:

- one for the internal protection (function G without external toroid);
- one for the external protection (function G with external toroid)

A typical application of function double G consists in simultaneous protection both against earth fault of the secondary of the transformer and of its connection cables to the circuit-breaker terminals (restricted earth fault protection), as well as against earth faults on the load side of the circuit-breaker (outside the restricted earth fault protection).

#### Example:

Figure 1 shows a fault on the load side of an Emax circuit-breaker: the fault current flows through one phase only and, if the vectorial sum of the currents detected by the four current transformers (CTs) results to be higher than the set threshold, the electronic release activates function G (and the circuit-breaker trips).

Figure 1

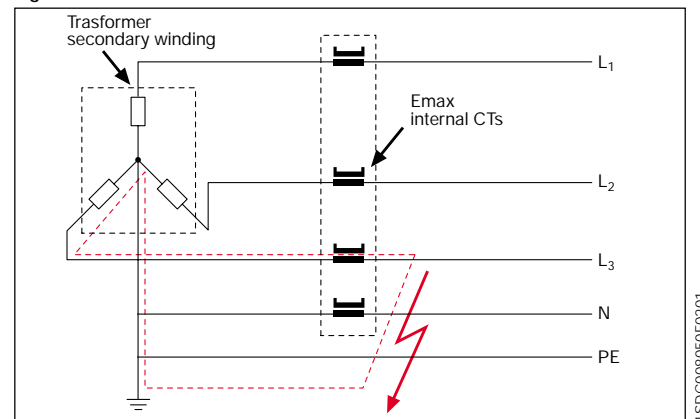

1SDC008050F0201

## Annex C: Application examples

### Advanced protection functions with PR123/P and PR333/P releases

With the same configuration, a fault on the supply side of the circuit-breaker (Figure 2) does not cause intervention of function G since the fault current does not affect either the CT of the phase or that of the neutral.

Figure 2

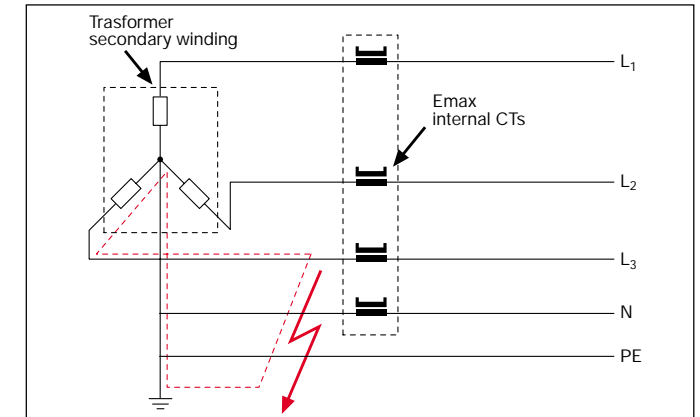

1SDC008051F0201

The use of function "double G" allows installation of an external toroid, as shown in Figure 3, so that earth faults on the supply side of Emax CB can be detected as well. In this case, the alarm contact of the second G is exploited in order to trip the circuit-breaker installed on the primary and to ensure fault disconnection.

Figure 3

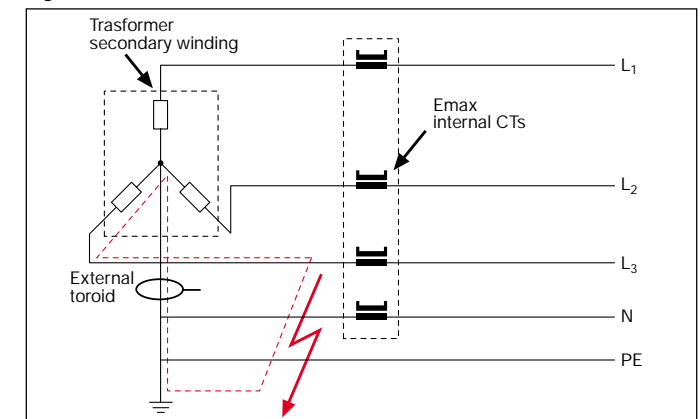

1SDC008052F0201

## Annex C: Application examples

### Advanced protection functions with PR123/P and PR333/P releases

If, with the same configuration as Figure 3, the fault occurs on the load side of the Emax circuit-breaker, the fault current would affect both the toroid as well as the current transformers on the phases. To define which circuit-breaker is to trip (MV or LV circuit-breaker), suitable coordination of the trip times is required: in particular, it is necessary to set the times so that LV circuit-breaker opening due to internal function G is faster than realization of the alarm signal coming from the external toroid. Therefore, thanks to the time-current discrimination between the two G protection functions, before the MV circuit-breaker on the primary of the transformer receives the trip command, the circuit-breaker on the LV side is able to eliminate the earth fault. Obviously, if the fault occurred on the supply side of the LV circuit-breaker, only the circuit-breaker on the MV side would trip.

The table shows the main characteristics of the range of toroids (available only in the closed version).

#### Characteristics of the toroid ranges

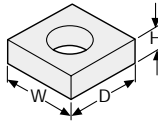
<b>Rated current</b>	<b>100 A, 250 A, 400 A, 800 A</b>
<b>Outer dimensions of the toroid</b>	
	W = 165 mm
	D = 160 mm
	H = 112 mm
<b>Internal diameter of the toroid</b>	<b>Ø = 112 mm</b>

1SDC008053F0201

## Annex C: Application examples

### Advanced protection functions with PR123/P and PR333/P releases

#### Double S

Thanks to the new PR123 and PR333 releases, which allows two thresholds of protection function S to be set independently and be activated simultaneously, selectivity can also be achieved under highly critical conditions. Here is an example of how, by using the new release, it is possible to obtain a better selectivity level compared with the use of a release without "double S". This is the wiring diagram of the system under examination; in particular, attention must be focussed on:

- the presence, on the supply side, of a MV circuit-breaker, which, for selectivity reasons, imposes low setting values for the Emax circuit-breaker on the LV side
- the presence of a LV/LV transformer which, due to the inrush currents, imposes high setting values for the circuit-breakers on its primary side

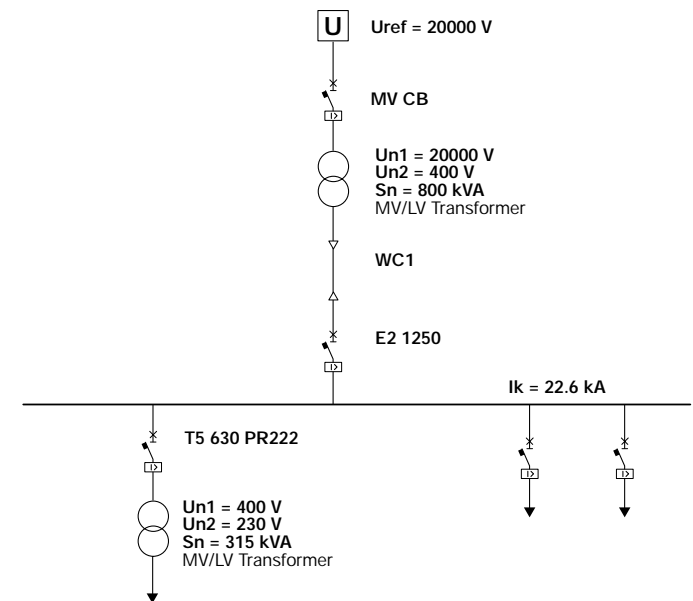

1SDC008054F0201



## Annex C: Application examples

### Advanced protection functions with PR123/P and PR333/P releases

#### Solution with a release without “double S”

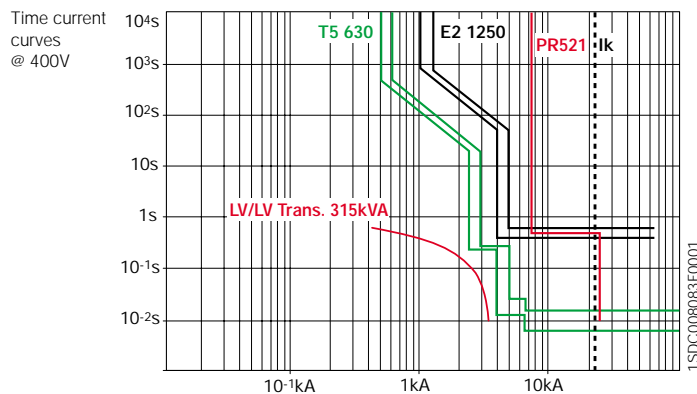

#### MV CB (PR521)

<b>50</b>	(I>): 50A	t=0.5s
<b>51</b>	(I>>): 500A	t=0s

		<b>E2N 1250 PR122</b> LSIG R1250	<b>T5V 630 PR222DS/P</b> LSIG R630
<b>L</b>	Setting	0.8	0.74
	Curve	108s	12s
<b>S</b> t=constant	Setting	3.5	4.2
	Curve	0.5s	0.25s
<b>I</b>	Setting	OFF	7

In the case of a short-circuit, the Emax E2 circuit-breaker and the MV circuit-breaker will open simultaneously with this solution. Attention must be paid to the fact that, owing to the value  $I_k$ , function I of the E2 circuit-breaker has to be disabled (I3=OFF) so that selectivity with the T5 on the load side is guaranteed.

## Annex C: Application examples

### Advanced protection functions with PR123/P and PR333/P releases

#### Solution with the PR123 release with “double S”

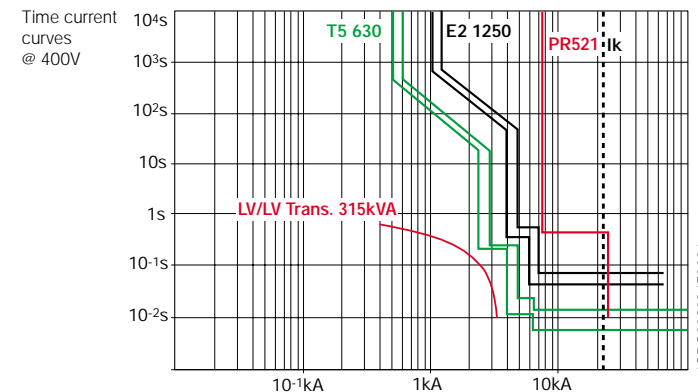

#### MV CB (PR521)

<b>50</b>	(I>): 50A	t=0.5s
<b>51</b>	(I>>): 500A	t=0s

		<b>E2N 1250 PR123</b> LSIG R1250	<b>T5V 630 PR222DS/P</b> LSIG R630
<b>L</b>	Setting	0.8	0.74
	Curve	108s	12s
<b>S</b> t=constant	Setting	3.5	4.2
	Curve	0.5s	0.25s
<b>S2</b> t=constant	Setting	5	-
	Curve	0.05s	-
<b>I</b>	Setting	OFF	7

As evident, by means of the “double S” function, selectivity can be achieved both with the T5 circuit-breaker on the load side as well as with the MV circuit-breaker on the supply side.

A further advantage obtained by using the “double S” function is the reduction in the time of permanence of high current values under short-circuit conditions, which results in lower thermal and dynamic stresses on the busbars and on the other installation components.



Due to possible developments of standards as well as of materials, the characteristics and dimensions specified in this document may only be considered binding after confirmation by ABB SACE.

---

ABB SACE S.p.A.  
An ABB Group Company  
*L.V. Breakers*  
Via Baioni, 35  
24123 Bergamo - Italy  
Tel.: +39 035.395.111 - Telefax: +39 035.395.306-433

***<http://www.abb.com>***

1SDC010001D0204



**ABB SACE**

**ABB**

# Electrical installation handbook

Volume 2

## Electrical devices

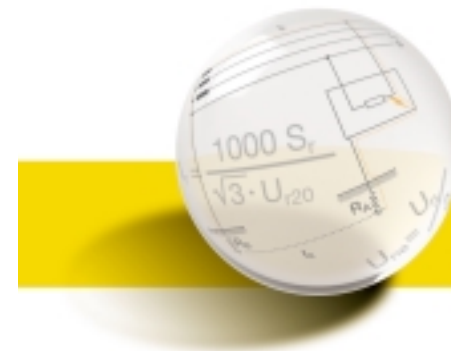

4<sup>th</sup> edition  
March 2006

First edition 2003  
Second edition 2004  
Third edition 2005  
Fourth edition 2006

Published by ABB SACE  
via Baioni, 35 - 24123 Bergamo (Italy)

All rights reserved

# Index

Introduction .....	2
<b>1 Standards</b>	
1.1 General aspects .....	3
1.2 IEC Standards for electrical installation .....	15
<b>2 Protection of feeders</b>	
2.1 Introduction .....	22
2.2 Installation and dimensioning of cables .....	25
2.2.1 Current carrying capacity and methods of installation .....	25
Installation not buried in the ground .....	31
Installation in ground .....	44
2.2.2 Voltage drop .....	56
2.2.3 Joule-effect losses .....	66
2.3 Protection against overload .....	67
2.4 Protection against short-circuit .....	70
2.5 Neutral and protective conductors .....	78
2.6 Busbar trunking systems .....	86
<b>3 Protection of electrical equipment</b>	
3.1 Protection and switching of lighting circuits .....	101
3.2 Protection and switching of generators .....	110
3.3 Protection and switching of motors .....	115
3.4 Protection and switching of transformers .....	135
<b>4 Power factor correction</b>	
4.1 General aspects .....	150
4.2 Power factor correction method .....	156
4.3 Circuit-breakers for the protection and switching of capacitor banks .....	163
<b>5 Protection of human beings</b>	
5.1 General aspects: effects of current on human beings .....	166
5.2 Distribution systems .....	169
5.3 Protection against both direct and indirect contact .....	172
5.4 TT system .....	175
5.5 TN system .....	178
5.6 IT system .....	181
5.7 Residual current devices .....	183
5.8 Maximum protected length for the protection of human beings .....	186
<b>6 Calculation of short-circuit current</b>	
6.1 General aspects .....	204
6.2 Fault typologies .....	204
6.3 Determination of the short-circuit current: "short-circuit power method" .....	206
6.3.1 Calculation of the short-circuit current .....	206
6.3.2 Calculation of the short-circuit power at the fault point .....	209
6.3.3 Calculation of the short-circuit current .....	210
6.3.4 Examples .....	212
6.4 Determination of the short-circuit current $I_k$ downstream of a cable as a function of the upstream one .....	216
6.5 Algebra of sequences .....	218
6.5.1 General aspects .....	218
6.5.2 Positive, negative and zero sequence systems .....	219
6.5.3 Calculation of short-circuit currents with the algebra of sequences .....	220
6.5.4 Positive, negative and zero sequence short-circuit impedances of electrical equipment .....	223
6.5.5 Formulas for the calculation of the fault currents as a function of the electrical parameters of the plant .....	226
6.6 Calculation of the peak value of the short-circuit current .....	229
6.7 Considerations about UPS contribution to the short-circuit .....	230
<b>Annex A: Calculation tools</b>	
A.1 Slide rules .....	233
A.2 DOCWin .....	238
<b>Annex B: Calculation of load current <math>I_b</math></b> .....	242
<b>Annex C: Harmonics</b> .....	246
<b>Annex D: Calculation of the coefficient <math>k</math> for the cables</b> .....	254
<b>Annex E: Main physical quantities and electrotechnical formulas</b> .....	258

---

## Introduction

### Scope and objectives

The scope of this electrical installation handbook is to provide the designer and user of electrical plants with a quick reference, immediate-use working tool. This is not intended to be a theoretical document, nor a technical catalogue, but, in addition to the latter, aims to be of help in the correct definition of equipment, in numerous practical installation situations.

The dimensioning of an electrical plant requires knowledge of different factors relating to, for example, installation utilities, the electrical conductors and other components; this knowledge leads the design engineer to consult numerous documents and technical catalogues. This electrical installation handbook, however, aims to supply, in a single document, tables for the quick definition of the main parameters of the components of an electrical plant and for the selection of the protection devices for a wide range of installations. Some application examples are included to aid comprehension of the selection tables.

### Electrical installation handbook users

The electrical installation handbook is a tool which is suitable for all those who are interested in electrical plants: useful for installers and maintenance technicians through brief yet important electrotechnical references, and for sales engineers through quick reference selection tables.

### Validity of the electrical installation handbook

Some tables show approximate values due to the generalization of the selection process, for example those regarding the constructional characteristics of electrical machinery. In every case, where possible, correction factors are given for actual conditions which may differ from the assumed ones. The tables are always drawn up conservatively, in favour of safety; for more accurate calculations, the use of DOCWin software is recommended for the dimensioning of electrical installations.

---

## 1 Standards

### 1.1 General aspects

In each technical field, and in particular in the electrical sector, a condition sufficient (even if not necessary) for the realization of plants according to the **“status of the art”** and a requirement essential to properly meet the demands of customers and of the community, is the respect of all the relevant laws and technical standards.

Therefore, a precise knowledge of the standards is the fundamental premise for a correct approach to the problems of the electrical plants which shall be designed in order to guarantee that **“acceptable safety level”** which is never absolute.

#### *Juridical Standards*

These are all the standards from which derive rules of behavior for the juridical persons who are under the sovereignty of that State.

#### *Technical Standards*

These standards are the whole of the prescriptions on the basis of which machines, apparatus, materials and the installations should be designed, manufactured and tested so that efficiency and function safety are ensured.

The technical standards, published by national and international bodies, are circumstantially drawn up and can have legal force when this is attributed by a legislative measure.

	Application fields		
	Electrotechnics and Electronics	Telecommunications	Mechanics, Ergonomics and Safety
International Body	IEC	ITU	ISO
European Body	CENELEC	ETSI	CEN

This technical collection takes into consideration only the bodies dealing with electrical and electronic technologies.

### IEC International Electrotechnical Commission

The *International Electrotechnical Commission* (IEC) was officially founded in 1906, with the aim of securing the international co-operation as regards standardization and certification in electrical and electronic technologies. This association is formed by the International Committees of over 40 countries all over the world.

The IEC publishes international standards, technical guides and reports which are the bases or, in any case, a reference of utmost importance for any national and European standardization activity.

IEC Standards are generally issued in two languages: English and French.

In 1991 the IEC has ratified co-operation agreements with CENELEC (European standardization body), for a common planning of new standardization activities and for parallel voting on standard drafts.

## 1 Standards

### CENELEC European Committee for Electrotechnical Standardization

The *European Committee for Electrotechnical Standardization* (CENELEC) was set up in 1973. Presently it comprises 29 countries (Austria, Belgium, Cyprus, Czech Republic, Denmark, Estonia, Finland, France, Germany, Greece, Hungary, Iceland, Ireland, Italy, Latvia, Lithuania, Luxembourg, Malta, Netherlands, Norway, Portugal, Poland, Romania, Slovakia, Slovenia, Spain, Sweden, Switzerland, United Kingdom) and cooperates with 8 affiliates (Albania, Bosnia and Herzegovina, Bulgaria, Croatia, Former Yugoslav Republic of Macedonia, Serbia and Montenegro, Turkey, Ukraine) which have first maintained the national documents side by side with the CENELEC ones and then replaced them with the Harmonized Documents (HD).

There is a difference between EN Standards and Harmonization Documents (HD): while the first ones have to be accepted at any level and without additions or modifications in the different countries, the second ones can be amended to meet particular national requirements.

EN Standards are generally issued in three languages: English, French and German.

From 1991 CENELEC cooperates with the IEC to accelerate the standards preparation process of International Standards.

CENELEC deals with specific subjects, for which standardization is urgently required.

When the study of a specific subject has already been started by the IEC, the European standardization body (CENELEC) can decide to accept or, whenever necessary, to amend the works already approved by the International standardization body.

### EC DIRECTIVES FOR ELECTRICAL EQUIPMENT

Among its institutional roles, the European Community has the task of promulgating directives which must be adopted by the different member states and then transposed into national law.

Once adopted, these directives come into juridical force and become a reference for manufacturers, installers, and dealers who must fulfill the duties prescribed by law.

Directives are based on the following principles:

- harmonization is limited to essential requirements;
- only the products which comply with the essential requirements specified by the directives can be marketed and put into service;
- the harmonized standards, whose reference numbers are published in the Official Journal of the European Communities and which are transposed into the national standards, are considered in compliance with the essential requirements;
- the applicability of the harmonized standards or of other technical specifications is facultative and manufacturers are free to choose other technical solutions which ensure compliance with the essential requirements;
- a manufacturer can choose among the different conformity evaluation procedure provided by the applicable directive.

The scope of each directive is to make manufacturers take all the necessary steps and measures so that the product does not affect the safety and health of persons, animals and property.

## 1 Standards

### “Low Voltage” Directive 73/23/CEE – 93/68/CEE

The Low Voltage Directive refers to any electrical equipment designed for use at a rated voltage from 50 to 1000 V for alternating current and from 75 to 1500 V for direct current.

In particular, it is applicable to any apparatus used for production, conversion, transmission, distribution and use of electrical power, such as machines, transformers, devices, measuring instruments, protection devices and wiring materials.

The following categories are outside the scope of this Directive:

- electrical equipment for use in an explosive atmosphere;
- electrical equipment for radiology and medical purposes;
- electrical parts for goods and passenger lifts;
- electrical energy meters;
- plugs and socket outlets for domestic use;
- electric fence controllers;
- radio-electrical interference;
- specialized electrical equipment, for use on ships, aircraft or railways, which complies with the safety provisions drawn up by international bodies in which the Member States participate.

### Directive EMC 89/336/EEC (“Electromagnetic Compatibility”)

The Directive on electromagnetic compatibility regards all the electrical and electronic apparatus as well as systems and installations containing electrical and/or electronic components. In particular, the apparatus covered by this Directive are divided into the following categories according to their characteristics:

- domestic radio and TV receivers;
- industrial manufacturing equipment;
- mobile radio equipment;
- mobile radio and commercial radio telephone equipment;
- medical and scientific apparatus;
- information technology equipment (ITE);
- domestic appliances and household electronic equipment;
- aeronautical and marine radio apparatus;
- educational electronic equipment;
- telecommunications networks and apparatus;
- radio and television broadcast transmitters;
- lights and fluorescent lamps.

The apparatus shall be so constructed that:

- a) the electromagnetic disturbance it generates does not exceed a level allowing radio and telecommunications equipment and other apparatus to operate as intended;
- b) the apparatus has an adequate level of intrinsic immunity to electromagnetic disturbance to enable it to operate as intended.

An apparatus is declared in conformity to the provisions at points a) and b) when the apparatus complies with the harmonized standards relevant to its product family or, in case there aren't any, with the general standards.

# 1 Standards

## CE conformity marking

The CE conformity marking shall indicate conformity to all the obligations imposed on the manufacturer, as regards his products, by virtue of the European Community directives providing for the affixing of the CE marking.



When the CE marking is affixed on a product, it represents a declaration of the manufacturer or of his authorized representative that the product in question conforms to all the applicable provisions including the conformity assessment procedures. This prevents the Member States from limiting the marketing and putting into service of products bearing the CE marking, unless this measure is justified by the proved non-conformity of the product.

Flow diagram for the conformity assessment procedures established by the Directive 73/23/EEC on electrical equipment designed for use within particular voltage range:

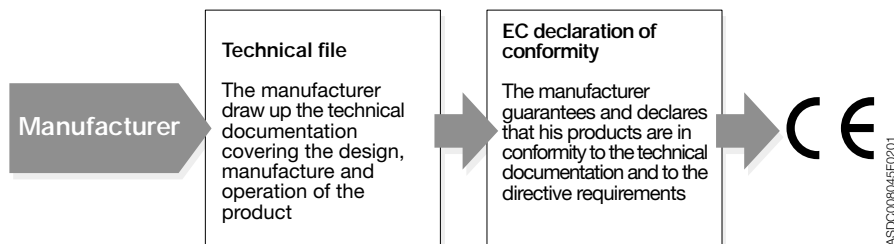

## Naval type approval

The environmental conditions which characterize the use of circuit breakers for on-board installations can be different from the service conditions in standard industrial environments; as a matter of fact, marine applications can require installation under particular conditions, such as:

- environments characterized by high temperature and humidity, including salt-mist atmosphere (damp-heat, salt-mist environment);
- on board environments (engine room) where the apparatus operate in the presence of vibrations characterized by considerable amplitude and duration.

In order to ensure the proper function in such environments, the shipping registers require that the apparatus has to be tested according to specific type approval tests, the most significant of which are vibration, dynamic inclination, humidity and dry-heat tests.

# 1 Standards

ABB SACE circuit-breakers (Isomax-Tmax-Emax) are approved by the following shipping registers:

• <b>RINA</b>	Registro Italiano Navale	Italian shipping register
• <b>DNV</b>	Det Norske Veritas	Norwegian shipping register
• <b>BV</b>	Bureau Veritas	French shipping register
• <b>GL</b>	Germanischer Lloyd	German shipping register
• <b>LRS</b>	Lloyd's Register of Shipping	British shipping register
• <b>ABS</b>	American Bureau of Shipping	American shipping register

It is always advisable to ask ABB SACE as regards the typologies and the performances of the certified circuit-breakers or to consult the section certificates in the website <http://bol.it.abb.com>.









## Marks of conformity to the relevant national and international Standards

The international and national marks of conformity are reported in the following table, for information only:









COUNTRY	Symbol	Mark designation	Applicability/Organization
EUROPE		-	Mark of compliance with the harmonized European standards listed in the ENEC Agreement.
AUSTRALIA		AS Mark	Electrical and non-electrical products. It guarantees compliance with SAA (Standard Association of Australia).
AUSTRALIA		S.A.A. Mark	Standards Association of Australia (S.A.A.). The Electricity Authority of New South Wales Sydney Australia
AUSTRIA		Austrian Test Mark	Installation equipment and materials











## 1 Standards

COUNTRY	Symbol	Mark designation	Applicability/Organization
AUSTRIA		ÖVE Identification Thread	Cables
BELGIUM		CEBEC Mark	Installation materials and electrical appliances
BELGIUM		CEBEC Mark	Conduits and ducts, conductors and flexible cords
BELGIUM		Certification of Conformity	Installation material and electrical appliances (in case there are no equivalent national standards or criteria)
CANADA		CSA Mark	Electrical and non-electrical products. This mark guarantees compliance with CSA (Canadian Standard Association)
CHINA		CCEE Mark	Great Wall Mark Commission for Certification of Electrical Equipment
Czech Republic		EZU' Mark	Electrotechnical Testing Institute
Slovakia Republic		EVPU' Mark	Electrotechnical Research and Design Institute





## 1 Standards

COUNTRY	Symbol	Mark designation	Applicability/Organization
CROATIA		KONKAR	Electrical Engineering Institute
DENMARK		DEMKO Approval Mark	Low voltage materials. This mark guarantees the compliance of the product with the requirements (safety) of the "Heavy Current Regulations"
FINLAND		Safety Mark of the Elektriska Inspektoratet	Low voltage material. This mark guarantees the compliance of the product with the requirements (safety) of the "Heavy Current Regulations"
FRANCE		ESC Mark	Household appliances
FRANCE		NF Mark	Conductors and cables – Conduits and ducting – Installation materials
FRANCE		NF Identification Thread	Cables
FRANCE		NF Mark	Portable motor-operated tools
FRANCE		NF Mark	Household appliances







## 1 Standards

COUNTRY	Symbol	Mark designation	Applicability/Organization
GERMANY		VDE Mark	For appliances and technical equipment, installation accessories such as plugs, sockets, fuses, wires and cables, as well as other components (capacitors, earthing systems, lamp holders and electronic devices)
GERMANY		VDE Identification Thread	Cables and cords
GERMANY		VDE Cable Mark	For cables, insulated cords, installation conduits and ducts
GERMANY		VDE-GS Mark for technical equipment	Safety mark for technical equipment to be affixed after the product has been tested and certified by the VDE Test Laboratory in Offenbach; the conformity mark is the mark VDE, which is granted both to be used alone as well as in combination with the mark GS
HUNGARY		MEEI	Hungarian Institute for Testing and Certification of Electrical Equipment
JAPAN		JIS Mark	Mark which guarantees compliance with the relevant Japanese Industrial Standard(s).
IRELAND		IIRS Mark	Electrical equipment
IRELAND		IIRS Mark	Electrical equipment



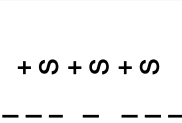





## 1 Standards

COUNTRY	Symbol	Mark designation	Applicability/Organization
ITALY		IMQ Mark	Mark to be affixed on electrical material for non-skilled users; it certifies compliance with the European Standard(s).
NORWAY		Norwegian Approval Mark	Mandatory safety approval for low voltage material and equipment
NETHERLANDS		KEMA-KEUR	General for all equipment
POLAND		KWE	Electrical products
RUSSIA		Certification of Conformity	Electrical and non-electrical products. It guarantees compliance with national standard (Gosstandard of Russia)
SINGAPORE		SISIR	Electrical and non-electrical products
SLOVENIA		SIQ	Slovenian Institute of Quality and Metrology
SPAIN		AEE	Electrical products. The mark is under the control of the Asociación Electrotécnica Española (Spanish Electrotechnical Association)

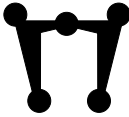

## 1 Standards

COUNTRY	Symbol	Mark designation	Applicability/Organization
SPAIN		AENOR	Asociación Española de Normalización y Certificación. (Spanish Standardization and Certification Association)
SWEDEN		SEMKO Mark	Mandatory safety approval for low voltage material and equipment.
SWITZERLAND		Safety Mark	Swiss low voltage material subject to mandatory approval (safety).
SWITZERLAND		–	Cables subject to mandatory approval
SWITZERLAND		SEV Safety Mark	Low voltage material subject to mandatory approval
UNITED KINGDOM		ASTA Mark	Mark which guarantees compliance with the relevant "British Standards"
UNITED KINGDOM		BASEC Mark	Mark which guarantees compliance with the "British Standards" for conductors, cables and ancillary products.
UNITED KINGDOM		BASEC Identification Thread	Cables

## 1 Standards

COUNTRY	Symbol	Mark designation	Applicability/Organization
UNITED KINGDOM		BEAB Safety Mark	Compliance with the "British Standards" for household appliances
UNITED KINGDOM		BSI Safety Mark	Compliance with the "British Standards"
UNITED KINGDOM		BEAB Kitemark	Compliance with the relevant "British Standards" regarding safety and performances
U.S.A.		UNDERWRITERS LABORATORIES Mark	Electrical and non-electrical products
U.S.A.		UNDERWRITERS LABORATORIES Mark	Electrical and non-electrical products
U.S.A.		UL Recognition	Electrical and non-electrical products
CEN		CEN Mark	Mark issued by the European Committee for Standardization (CEN); it guarantees compliance with the European Standards.
CENELEC		Mark	Cables

## 1 Standards

COUNTRY	Symbol	Mark designation	Applicability/Organization
CENELEC		Harmonization Mark	Certification mark providing assurance that the harmonized cable complies with the relevant harmonized CENELEC Standards – identification thread
EC		Ex EUROPEA Mark	Mark assuring the compliance with the relevant European Standards of the products to be used in environments with explosion hazards
CEEel		CEEel Mark	Mark which is applicable to some household appliances (shavers, electric clocks, etc).

### EC - Declaration of Conformity

The EC Declaration of Conformity is the statement of the manufacturer, who declares under his own responsibility that all the equipment, procedures or services refer and comply with specific standards (directives) or other normative documents.

The EC Declaration of Conformity should contain the following information:

- name and address of the manufacturer or by its European representative;
- description of the product;
- reference to the harmonized standards and directives involved;
- any reference to the technical specifications of conformity;
- the two last digits of the year of affixing of the CE marking;
- identification of the signer.

A copy of the EC Declaration of Conformity shall be kept by the manufacturer or by his representative together with the technical documentation.

## 1 Standards

### 1.2 IEC Standards for electrical installation

STANDARD	YEAR	TITLE
IEC 60027-1	1992	Letter symbols to be used in electrical technology - Part 1: General
IEC 60034-1	2004	Rotating electrical machines - Part 1: Rating and performance
IEC 60617-DB-12M	2001	Graphical symbols for diagrams - 12-month subscription to online database comprising parts 2 to 11 of IEC 60617
IEC 61082-1	1991	Preparation of documents used in electrotechnology - Part 1: General requirements
IEC 61082-2	1993	Preparation of documents used in electrotechnology - Part 2: Function-oriented diagrams
IEC 61082-3	1993	Preparation of documents used in electrotechnology - Part 3: Connection diagrams, tables and lists
IEC 61082-4	1996	Preparation of documents used in electrotechnology - Part 4: Location and installation documents
IEC 60038	2002	IEC standard voltages
IEC 60664-1	2002	Insulation coordination for equipment within low-voltage systems - Part 1: Principles, requirements and tests
IEC 60909-0	2001	Short-circuit currents in three-phase a.c. systems - Part 0: Calculation of currents
IEC 60865-1	1993	Short-circuit currents - Calculation of effects - Part 1: Definitions and calculation methods
IEC 60781	1989	Application guide for calculation of short-circuit currents in low-voltage radial systems
IEC 60076-1	2000	Power transformers - Part 1: General
IEC 60076-2	1993	Power transformers - Part 2: Temperature rise
IEC 60076-3	2000	Power transformers - Part 3: Insulation levels, dielectric tests and external clearances in air
IEC 60076-5	2006	Power transformers - Part 5: Ability to withstand short circuit
IEC/TR 60616	1978	Terminal and tapping markings for power transformers
IEC 60076-11	2004	Power transformers - Part 11: Dry-type transformers
IEC 60445	1999	Basic and safety principles for man-machine interface, marking and identification - Identification of equipment terminals and of terminations of certain designated conductors, including general rules for an alphanumeric system

## 1 Standards

STANDARD	YEAR	TITLE
IEC 60073	2002	Basic and safety principles for man-machine interface, marking and identification – Coding for indicators and actuators
IEC 60446	1999	Basic and safety principles for man-machine interface, marking and identification - Identification of conductors by colours or numerals
IEC 60447	2004	Basic and safety principles for man-machine interface, marking and identification - Actuating principles
IEC 60947-1	2004	Low-voltage switchgear and controlgear - Part 1: General rules
IEC 60947-2	2003	Low-voltage switchgear and controlgear - Part 2: Circuit-breakers
IEC 60947-3	2005	Low-voltage switchgear and controlgear - Part 3: Switches, disconnectors, switch-disconnectors and fuse-combination units
IEC 60947-4-1	2002	Low-voltage switchgear and controlgear - Part 4-1: Contactors and motor-starters – Electromechanical contactors and motor-starters
IEC 60947-4-2	2002	Low-voltage switchgear and controlgear - Part 4-2: Contactors and motor-starters – AC semiconductor motor controllers and starters
IEC 60947-4-3	1999	Low-voltage switchgear and controlgear - Part 4-3: Contactors and motor-starters – AC semiconductor controllers and contactors for non-motor loads
IEC 60947-5-1	2003	Low-voltage switchgear and controlgear - Part 5-1: Control circuit devices and switching elements - Electromechanical control circuit devices
IEC 60947-5-2	2004	Low-voltage switchgear and controlgear - Part 5-2: Control circuit devices and switching elements – Proximity switches
IEC 60947-5-3	2005	Low-voltage switchgear and controlgear - Part 5-3: Control circuit devices and switching elements – Requirements for proximity devices with defined behaviour under fault conditions
IEC 60947-5-4	2002	Low-voltage switchgear and controlgear - Part 5: Control circuit devices and switching elements – Section 4: Method of assessing the performance of low energy contacts. Special tests
IEC 60947-5-5	2005	Low-voltage switchgear and controlgear - Part 5-5: Control circuit devices and switching elements - Electrical emergency stop device with mechanical latching function

## 1 Standards

STANDARD	YEAR	TITLE
IEC 60947-5-6	1999	Low-voltage switchgear and controlgear - Part 5-6: Control circuit devices and switching elements – DC interface for proximity sensors and switching amplifiers (NAMUR)
IEC 60947-6-1	2005	Low-voltage switchgear and controlgear - Part 6-1: Multiple function equipment – Automatic transfer switching equipment
IEC 60947-6-2	2002	Low-voltage switchgear and controlgear - Part 6-2: Multiple function equipment - Control and protective switching devices (or equipment) (CPS)
IEC 60947-7-1	2002	Low-voltage switchgear and controlgear - Part 7: Ancillary equipment - Section 1: Terminal blocks for copper conductors
IEC 60947-7-2	2002	Low-voltage switchgear and controlgear - Part 7: Ancillary equipment - Section 2: Protective conductor terminal blocks for copper conductors
IEC 60439-1	2004	Low-voltage switchgear and controlgear assemblies - Part 1: Type-tested and partially type-tested assemblies
IEC 60439-2	2005	Low-voltage switchgear and controlgear assemblies - Part 2: Particular requirements for busbar trunking systems (busways)
IEC 60439-3	2001	Low-voltage switchgear and controlgear assemblies - Part 3: Particular requirements for low-voltage switchgear and controlgear assemblies intended to be installed in places where unskilled persons have access for their use - Distribution boards
IEC 60439-4	2004	Low-voltage switchgear and controlgear assemblies - Part 4: Particular requirements for assemblies for construction sites (ACS)
IEC 60439-5	1998	Low-voltage switchgear and controlgear assemblies - Part 5: Particular requirements for assemblies intended to be installed outdoors in public places - Cable distribution cabinets (CDCs) for power distribution in networks
IEC 61095	2000	Electromechanical contactors for household and similar purposes

## 1 Standards

STANDARD	YEAR	TITLE
IEC/TR 60890	1987	A method of temperature-rise assessment by extrapolation for partially type-tested assemblies (PTTA) of low-voltage switchgear and controlgear
IEC/TR 61117	1992	A method for assessing the short-circuit withstand strength of partially type-tested assemblies (PTTA)
IEC 60092-303	1980	Electrical installations in ships. Part 303: Equipment - Transformers for power and lighting
IEC 60092-301	1980	Electrical installations in ships. Part 301: Equipment - Generators and motors
IEC 60092-101	2002	Electrical installations in ships - Part 101: Definitions and general requirements
IEC 60092-401	1980	Electrical installations in ships. Part 401: Installation and test of completed installation
IEC 60092-201	1994	Electrical installations in ships - Part 201: System design - General
IEC 60092-202	1994	Electrical installations in ships - Part 202: System design - Protection
IEC 60092-302	1997	Electrical installations in ships - Part 302: Low-voltage switchgear and controlgear assemblies
IEC 60092-350	2001	Electrical installations in ships - Part 350: Shipboard power cables - General construction and test requirements
IEC 60092-352	2005	Electrical installations in ships - Part 352: Choice and installation of electrical cable
IEC 60364-5-52	2001	Electrical installations of buildings - Part 5-52: Selection and erection of electrical equipment – Wiring systems
IEC 60227		Polyvinyl chloride insulated cables of rated voltages up to and including 450/750 V
	1998	Part 1: General requirements
	2003	Part 2: Test methods
	1997	Part 3: Non-sheathed cables for fixed wiring
	1997	Part 4: Sheathed cables for fixed wiring
	2003	Part 5: Flexible cables (cords)
	2001	Part 6: Lift cables and cables for flexible connections
	2003	Part 7: Flexible cables screened and unscreened with two or more conductors
IEC 60228	2004	Conductors of insulated cables
IEC 60245		Rubber insulated cables - Rated voltages up to and including 450/750 V
	2003	Part 1: General requirements
	1998	Part 2: Test methods
	1994	Part 3: Heat resistant silicone insulated cables
	1994	Part 4: Cords and flexible cables

## 1 Standards

STANDARD	YEAR	TITLE
	2004	Part 4: Cord and flexible cables
	1994	Part 5: Lift cables
	1994	Part 6: Arc welding electrode cables
	1994	Part 7: Heat resistant ethylene-vinyl acetate rubber insulated cables
	2004	Part 8: Cords for applications requiring high flexibility
IEC 60309-2	2005	Plugs, socket-outlets and couplers for industrial purposes - Part 2: Dimensional interchangeability requirements for pin and contact-tube accessories
IEC 61008-1	2002	Residual current operated circuit-breakers without integral overcurrent protection for household and similar uses (RCCBs) - Part 1: General rules
IEC 61008-2-1	1990	Residual current operated circuit-breakers without integral overcurrent protection for household and similar uses (RCCBs). Part 2-1: Applicability of the general rules to RCCB's functionally independent of line voltage
IEC 61008-2-2	1990	Residual current operated circuit-breakers without integral overcurrent protection for household and similar uses (RCCB's). Part 2-2: Applicability of the general rules to RCCB's functionally dependent on line voltage
IEC 61009-1	2003	Residual current operated circuit-breakers with integral overcurrent protection for household and similar uses (RCBOs) - Part 1: General rules
IEC 61009-2-1	1991	Residual current operated circuit-breakers with integral overcurrent protection for household and similar uses (RCBO's) Part 2-1: Applicability of the general rules to RCBO's functionally independent of line voltage
IEC 61009-2-2	1991	Residual current operated circuit-breakers with integral overcurrent protection for household and similar uses (RCBO's) - Part 2-2: Applicability of the general rules to RCBO's functionally dependent on line voltage
IEC 60670-1	2002	Boxes and enclosures for electrical accessories for household and similar fixed electrical installations - Part 1: General requirements
IEC 60669-2-1	2002	Switches for household and similar fixed electrical installations - Part 2-1: Particular requirements – Electronic switches
IEC 60669-2-2	2002	Switches for household and similar fixed electrical installations - Part 2: Particular requirements – Section 2: Remote-control switches (RCS)
IEC 60669-2-3	1997	Switches for household and similar fixed electrical installations - Part 2-3: Particular requirements – Time-delay switches (TDS)

## 1 Standards

STANDARD	YEAR	TITLE
IEC 60079-10	2002	Electrical apparatus for explosive gas atmospheres - Part 10: Classification of hazardous areas
IEC 60079-14	2002	Electrical apparatus for explosive gas atmospheres - Part 14: Electrical installations in hazardous areas (other than mines)
IEC 60079-17	2002	Electrical apparatus for explosive gas atmospheres - Part 17: Inspection and maintenance of electrical installations in hazardous areas (other than mines)
IEC 60269-1	2005	Low-voltage fuses - Part 1: General requirements
IEC 60269-2	1986	Low-voltage fuses. Part 2: Supplementary requirements for fuses for use by authorized persons (fuses mainly for industrial application)
IEC 60269-3-1	2004	Low-voltage fuses - Part 3-1: Supplementary requirements for fuses for use by unskilled persons (fuses mainly for household and similar applications) - Sections I to IV: Examples of types of standardized fuses
IEC 60127-1/10		Miniature fuses -
	2003	Part 1: Definitions for miniature fuses and general requirements for miniature fuse-links
	2003	Part 2: Cartridge fuse-links
	1988	Part 3: Sub-miniature fuse-links
	2005	Part 4: Universal Modular Fuse-Links (UMF) - Through-hole and surface mount types
	1988	Part 5: Guidelines for quality assessment of miniature fuse-links
	1994	Part 6: Fuse-holders for miniature cartridge fuse-links
	2001	Part 10: User guide for miniature fuses
IEC 60730-2-7	1990	Automatic electrical controls for household and similar use. Part 2: Particular requirements for timers and time switches
IEC 60364-1	2005	Low-voltage electrical installations Part 1: Fundamental principles, assessment of general characteristics, definitions
IEC 60364-4-41	2005	Low-voltage electrical installations Part 4-41: Protection for safety - Protection against electric shock
IEC 60364-4-42	2001	Electrical installations of buildings Part 4-42: Protection for safety - Protection against thermal effects

## 1 Standards

STANDARD	YEAR	TITLE
IEC 60364-4-43	2001	Electrical installations of buildings Part 4-43: Protection for safety - Protection against overcurrent
IEC 60364-4-44	2003	Electrical installations of buildings Part 4-44: Protection for safety - Protection against voltage disturbances and electromagnetic disturbances
IEC 60364-5-51	2005	Electrical installations of buildings Part 5-51: Selection and erection of electrical equipment Common rules
IEC 60364-5-52	2001	Electrical installations of buildings Part 5-52: Selection and erection of electrical equipment Wiring systems
IEC 60364-5-53	2002	Electrical installations of buildings Part 5-53: Selection and erection of electrical equipment Isolation, switching and control
IEC 60364-5-54	2002	Electrical installations of buildings Part 5-54: Selection and erection of electrical equipment Earthing arrangements, protective conductors and protective bonding conductors
IEC 60364-5-55	2002	Electrical installations of buildings Part 5-55: Selection and erection of electrical equipment Other equipment
IEC 60364-6-61	2001	Electrical installations of buildings Part 6-61: Verification - Initial verification
IEC 60364-7	1984...2005	Electrical installations of buildings Part 7: Requirements for special installations or locations
IEC 60529	2001	Degrees of protection provided by enclosures (IP Code)
IEC 61032	1997	Protection of persons and equipment by enclosures - Probes for verification
IEC/TR 61000-1-1	1992	Electromagnetic compatibility (EMC) Part 1: General - Section 1: application and interpretation of fundamental definitions and terms
IEC/TR 61000-1-2	2001	Electromagnetic compatibility (EMC) Part 1-2: General - Methodology for the achievement of the functional safety of electrical and electronic equipment with regard to electromagnetic phenomena
IEC/TR 61000-1-3	2002	Electromagnetic compatibility (EMC) Part 1-3: General - The effects of high-altitude EMP (HEMP) on civil equipment and systems

## 2 Protection of feeders

### 2.1 Introduction

The following definitions regarding electrical installations are derived from the Standard IEC 60050.

#### Characteristics of installations

**Electrical installation** (of a building) An assembly of associated electrical equipment to fulfil a specific purpose and having coordinated characteristics.

**Origin of an electrical installation** The point at which electrical energy is delivered to an installation.

**Neutral conductor** (symbol N) A conductor connected to the neutral point of a system and capable of contributing to the transmission of electrical energy.

**Protective conductor PE** A conductor required by some measures for protection against electric shock for electrically connecting any of the following parts:

- exposed conductive parts;
- extraneous conductive parts;
- main earthing terminal;
- earth electrode;
- earthed point of the source or artificial neutral.

**PEN conductor** An earthed conductor combining the functions of both protective conductor and neutral conductor

**Ambient temperature** The temperature of the air or other medium where the equipment is to be used.

#### Voltages

**Nominal voltage** (of an installation) Voltage by which an installation or part of an installation is designated.

Note: the actual voltage may differ from the nominal voltage by a quantity within permitted tolerances.

#### Currents

**Design current** (of a circuit) The current intended to be carried by a circuit in normal service.

**Current-carrying capacity** (of a conductor) The maximum current which can be carried continuously by a conductor under specified conditions without its steady-state temperature exceeding a specified value.

**Overcurrent** Any current exceeding the rated value. For conductors, the rated value is the current-carrying capacity.

**Overload current** (of a circuit) An overcurrent occurring in a circuit in the absence of an electrical fault.

**Short-circuit current** An overcurrent resulting from a fault of negligible impedance between live conductors having a difference in potential under normal operating conditions.

## 2 Protection of feeders

**Conventional operating current** (of a protective device) A specified value of the current which cause the protective device to operate within a specified time, designated conventional time.

**Overcurrent detection** A function establishing that the value of current in a circuit exceeds a predetermined value for a specified length of time.

**Leakage current** Electrical current in an unwanted conductive path other than a short circuit.

**Fault current** The current flowing at a given point of a network resulting from a fault at another point of this network.

#### Wiring systems

**Wiring system** An assembly made up of a cable or cables or busbars and the parts which secure and, if necessary, enclose the cable(s) or busbars.

#### Electrical circuits

**Electrical circuit** (of an installation) An assembly of electrical equipment of the installation supplied from the same origin and protected against overcurrents by the same protective device(s).

**Distribution circuit** (of buildings) A circuit supplying a distribution board.

**Final circuit (of building)** A circuit connected directly to current using equipment or to socket-outlets.

#### Other equipment

**Electrical equipment** Any item used for such purposes as generation, conversion, transmission, distribution or utilization of electrical energy, such as machines, transformers, apparatus, measuring instruments, protective devices, equipment for wiring systems, appliances.

**Current-using equipment** Equipment intended to convert electrical energy into another form of energy, for example light, heat, and motive power

**Switchgear and controlgear** Equipment provided to be connected to an electrical circuit for the purpose of carrying out one or more of the following functions: protection, control, isolation, switching.

**Portable equipment** Equipment which is moved while in operation or which can easily be moved from one place to another while connected to the supply.

**Hand-held equipment** Portable equipment intended to be held in the hand during normal use, in which the motor, if any, forms an integral part of the equipment.

**Stationary equipment** Either fixed equipment or equipment not provided with a carrying handle and having such a mass that it cannot easily be moved.

**Fixed equipment** Equipment fastened to a support or otherwise secured in a specific location.



## 2 Protection of feeders

### Installation dimensioning

The flow chart below suggests the procedure to follow for the correct dimensioning of a plant.

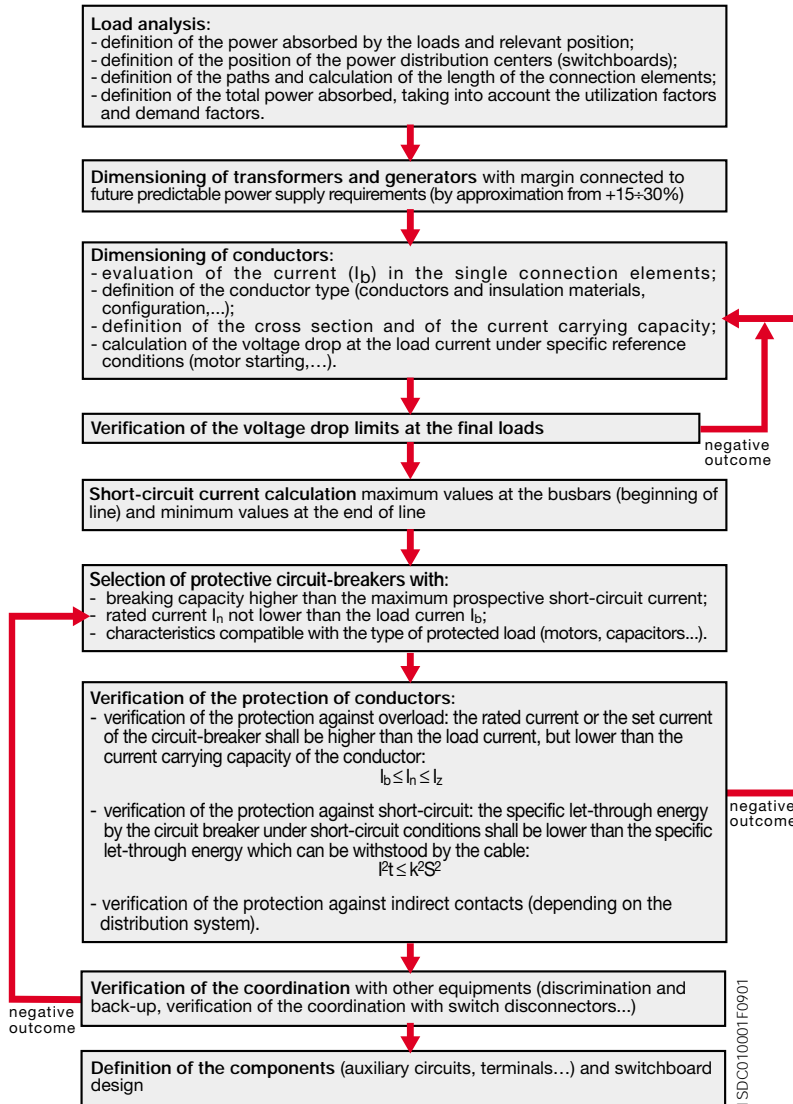

## 2 Protection of feeders

### 2.2 Installation and dimensioning of cables

For a correct dimensioning of a cable, it is necessary to:

- choose the type of cable and installation according to the environment;
- choose the cross section according to the load current;
- verify the voltage drop.

#### 2.2.1 Current carrying capacity and methods of installation

##### Selection of the cable

The international reference Standard ruling the installation and calculation of the current carrying capacity of cables in residential and industrial buildings is IEC 60364-5-52 "Electrical installations of buildings – Part 5-52 Selection and Erection of Electrical Equipment- Wiring systems".

The following parameters are used to select the cable type:

- conductive material (copper or aluminium): the choice depends on cost, dimension and weight requirements, resistance to corrosive environments (chemical reagents or oxidizing elements). In general, the carrying capacity of a copper conductor is about 30% greater than the carrying capacity of an aluminium conductor of the same cross section. An aluminium conductor of the same cross section has an electrical resistance about 60% higher and a weight half to one third lower than a copper conductor.
- insulation material (none, PVC, XLPE-EPR): the insulation material affects the maximum temperature under normal and short-circuit conditions and therefore the exploitation of the conductor cross section [see Chapter 2.4 "Protection against short-circuit"].
- the type of conductor (bare conductor, single-core cable without sheath, single-core cable with sheath, multi-core cable) is selected according to mechanical resistance, degree of insulation and difficulty of installation (bends, joints along the route, barriers...) required by the method of installation.

Table 1 shows the types of conductors permitted by the different methods of installation.

**Table 1: Selection of wiring systems**

Conductors and cables	Method of installation							
	Cable trunking (including skirting trunking, flush floor trunking)				Cable ladder Cable tray Cable brackets			
	Without fixings	Clipped direct	Conduit	Cable ducting	On-insulators	Support wire		
Bare conductors	-	-	-	-	-	-	+	-
Insulated conductors	-	-	+	+	+	-	+	-
Sheathed cables (including armoured and mineral insulated)	Multi-core	+	+	+	+	+	0	+
	Single-core	0	+	+	+	+	0	+

+ Permitted.  
 - Not permitted.  
 0 Not applicable, or not normally used in practice.

## 2 Protection of feeders

For industrial installations, multi-core cables are rarely used with cross section greater than 95 mm<sup>2</sup>.

### Methods of installation

To define the current carrying capacity of the conductor and therefore to identify the correct cross section for the load current, the standardized method of installation that better suits the actual installation situation must be identified among those described in the mentioned reference Standard.

From Tables 2 and 3 it is possible to identify the installation identification number, the method of installation (A1, A2, B1, B2, C, D, E, F, G) and the tables to define the theoretical current carrying capacity of the conductor and any correction factors required to allow for particular environmental and installation situations.













**Table 2: Method of installation**

Situations	Method of installation							
	Without fixings	With fixings	Cable trunking (including skirting trunking, flush floor trunking)		Cable ducting	Cable ladder Cable tray Cable brackets	On insulators	Support wire
Building voids	40, 46, 15, 16	0	15, 16	-	0	30, 31, 32, 33, 34	-	-
Cable channel	56	56	54, 55	0	44	30, 31, 32, 33, 34	-	-
Buried in Ground	72, 73	0	70, 71	-	70, 71	0	-	-
Embedded in Structure	57, 58	3	1, 2, 59, 60	50, 51, 52, 53	44, 45	0	-	-
Surface Mounted	-	20, 21	4, 5	6, 7, 8, 9, 12, 13, 14	6, 7, 8, 9	30, 31, 32, 33, 34	36	-
Overhead	-	-	0	10, 11	-	30, 31, 32, 33, 34	36	35

The number in each box indicates the item number in Table 3.  
 - Not permitted.  
 0 Not applicable or not normally used in practice.

## 2 Protection of feeders

**Table 3: Examples of methods of installation**



Methods of installation	Item n.	Description	Reference method of installation to be used to obtain current-carrying capacity
	Room 1	Insulated conductors or single-core cables in conduit in a thermally insulated wall	A1
	Room 2	Multi-core cables in conduit in a thermally insulated wall	A2
	Room 3	Multi-core cable direct in a thermally insulated wall	A1
	4	Insulated conductors or single-core cables in conduit on a wooden, or masonry wall or spaced less than 0.3 times conduit diameter from it	B1
	5	Multi-core cable in conduit on a wooden, or masonry wall or spaced less than 0.3 times conduit diameter from it	B2
	6 7	Insulated conductors or single-core cables in cable trunking on a wooden wall – run horizontally (6) – run vertically (7)	B1
	8 9	Insulated conductors or single-core cable in suspended cable trunking (8) Multi-core cable in suspended cable trunking (9)	B1 (8) or B2 (9)
	12	Insulated conductors or single-core cable run in mouldings	A1
	13 14	Insulated conductors or single-core cables in skirting trunking (13) Multi-core cable in skirting trunking (14)	B1 (13) or B2 (14)
	15	Insulated conductors in conduit or single-core or multi-core cable in architrave	A1
	16	Insulated conductors in conduit or single-core or multi-core cable in window frames	A1
	20 21	Single-core or multi-core cables: – fixed on, or spaced less than 0.3 times (20) cable diameter from a wooden wall – fixed directly under a wooden ceiling (21)	C

1SDC010001F0201

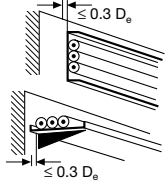
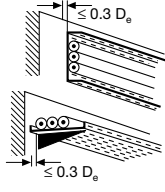
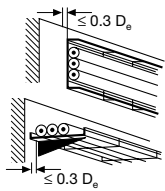
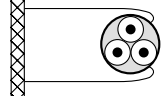
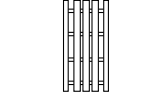
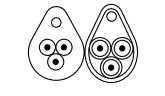
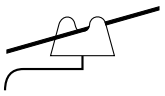

## 2 Protection of feeders

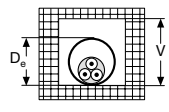
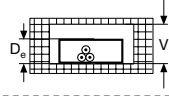
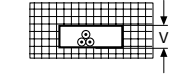
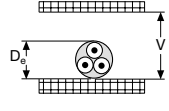
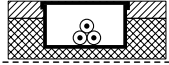
Methods of installation	Item n.	Description	Reference method of installation to be used to obtain current-carrying capacity
	30	On unperforated tray <sup>1</sup>	C
	31	On perforated tray <sup>1</sup>	E or F
	32	On brackets or on a wire mesh <sup>1</sup>	E or F
	33	Spaced more than 0.3 times cable diameter from a wall	E or F or G
	34	On ladder	E or F
	35	Single-core or multi-core cable suspended from or incorporating a support wire	E or F
	36	Bare or insulated conductors on insulators	G

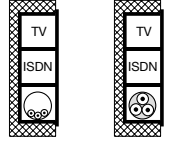
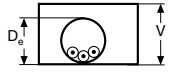
## 2 Protection of feeders

Methods of installation	Item n.	Description	Reference method of installation to be used to obtain current-carrying capacity
	40	Single-core or multi-core cable in a building void <sup>2</sup>	1.5 D <sub>e</sub> ≤ V < 20 D <sub>e</sub> B2 V ≥ 20 D <sub>e</sub> B1
	24	Insulated conductors in cable ducting in a building void <sup>2</sup>	1.5 D <sub>e</sub> ≤ V < 20 D <sub>e</sub> B2 V ≥ 20 D <sub>e</sub> B1
	44	Insulated conductors in cable ducting in masonry having a thermal resistivity not greater than 2 Km/W	1.5 D <sub>e</sub> ≤ V < 5 D <sub>e</sub> B2 5 D <sub>e</sub> ≤ V < 50 D <sub>e</sub> B1
	46	Single-core or multi-core cable: - in a ceiling void - in a suspended floor <sup>1</sup>	1.5 D <sub>e</sub> ≤ V < 5 D <sub>e</sub> B2 5 D <sub>e</sub> ≤ V < 50 D <sub>e</sub> B1
	50	Insulated conductors or single-core cable in flush cable trunking in the floor	B1
	51	Multi-core cable in flush cable trunking in the floor	B2
	52 53	Insulated conductors or single-core cables in embedded trunking (52) Multi-core cable in embedded trunking (53)	B1 (52) or B2 (53)
	54	Insulated conductors or single-core cables in conduit in an unventilated cable channel run horizontally or vertically <sup>2</sup>	1.5 D <sub>e</sub> ≤ V < 20 D <sub>e</sub> B2 V ≥ 20 D <sub>e</sub> B1

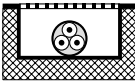
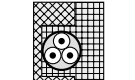
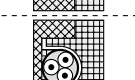
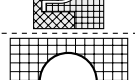
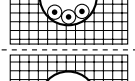
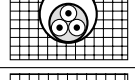
## 2 Protection of feeders

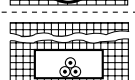
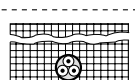
Methods of installation	Item n.	Description	Reference method of installation to be used to obtain current-carrying capacity
	55	Insulated conductors in conduit in an open or ventilated cable channel in the floor	B1
	56	Sheathed single-core or multi-core cable in an open or ventilated cable channel run horizontally or vertically	B1
	57	Single-core or multi-core cable direct in masonry having a thermal resistivity not greater than 2 Km/W Without added mechanical protection	C
	58	Single-core or multi-core cable direct in masonry having a thermal resistivity not greater than 2 Km/W With added mechanical protection	C
	59	Insulated conductors or single-core cables in conduit in masonry	B1
	60	Multi-core cables in conduit in masonry	B2
	70	Multi-core cable in conduit or in cable ducting in the ground	D
	71	Single-core cable in conduit or in cable ducting in the ground	D
	72	Sheathed single-core or multi-core cables direct in the ground - without added mechanical protection	D
	73	Sheathed single-core or multi-core cables direct in the ground - with added mechanical protection	D

1SDC010003F0201

<sup>1</sup>D<sub>0</sub> is the external diameter of a multi-core cable:  
 - 2.2 x the cable diameter when three single core cables are bound in trefoil, or  
 - 3 x the cable diameter when three single core cables are laid in flat formation.

<sup>2</sup>D<sub>v</sub> is the external diameter of conduit or vertical depth of cable ducting.

V is the smaller dimension or diameter of a masonry duct or void, or the vertical depth of a rectangular duct, floor or ceiling void.  
 The depth of the channel is more important than the width.

## 2 Protection of feeders

### Installation not buried in the ground: choice of the cross section according to cable carrying capacity and type of installation

The cable carrying capacity of a cable that is not buried in the ground is obtained by using this formula:

$$I_z = I_0 k_1 k_2 = I_0 k_{tot}$$

where:

- I<sub>0</sub> is the current carrying capacity of the single conductor at 30 °C reference ambient temperature;
- k<sub>1</sub> is the correction factor if the ambient temperature is other than 30 °C;
- k<sub>2</sub> is the correction factor for cables installed bunched or in layers or for cables installed in a layer on several supports.

#### Correction factor k<sub>1</sub>

The current carrying capacity of the cables that are not buried in the ground refers to 30 °C ambient temperature. If the ambient temperature of the place of installation is different from this reference temperature, the correction factor k<sub>1</sub> on Table 4 shall be used, according to the insulation material.

Table 4: Correction factor for ambient air temperature other than 30 °C

Ambient temperature (a) °C	Insulation			
	PVC	XLPE and EPR	Mineral (a)	
			PVC covered or bare and exposed to touch 70 °C	Bare not exposed to touch 105 °C
10	1.22	1.15	1.26	1.14
15	1.17	1.12	1.20	1.11
20	1.12	1.08	1.14	1.07
25	1.06	1.04	1.07	1.04
35	0.94	0.96	0.93	0.96
40	0.87	0.91	0.85	0.92
45	0.79	0.87	0.87	0.88
50	0.71	0.82	0.67	0.84
55	0.61	0.76	0.57	0.80
60	0.50	0.71	0.45	0.75
65	-	0.65	-	0.70
70	-	0.58	-	0.65
75	-	0.50	-	0.60
80	-	0.41	-	0.54
85	-	-	-	0.47
90	-	-	-	0.40
95	-	-	-	0.32

(a) For higher ambient temperatures, consult manufacturer.

## 2 Protection of feeders

### Correction factor $k_2$

The cable current carrying capacity is influenced by the presence of other cables installed nearby. The heat dissipation of a single cable is different from that of the same cable when installed next to the other ones. The factor  $k_2$  is tabled according to the installation of cables laid close together in layers or bunches.

#### Definition of layer or bunch

*layer*: several circuits constituted by cables installed one next to another, spaced or not, arranged horizontally or vertically. The cables on a layer are installed on a wall, tray, ceiling, floor or on a cable ladder;

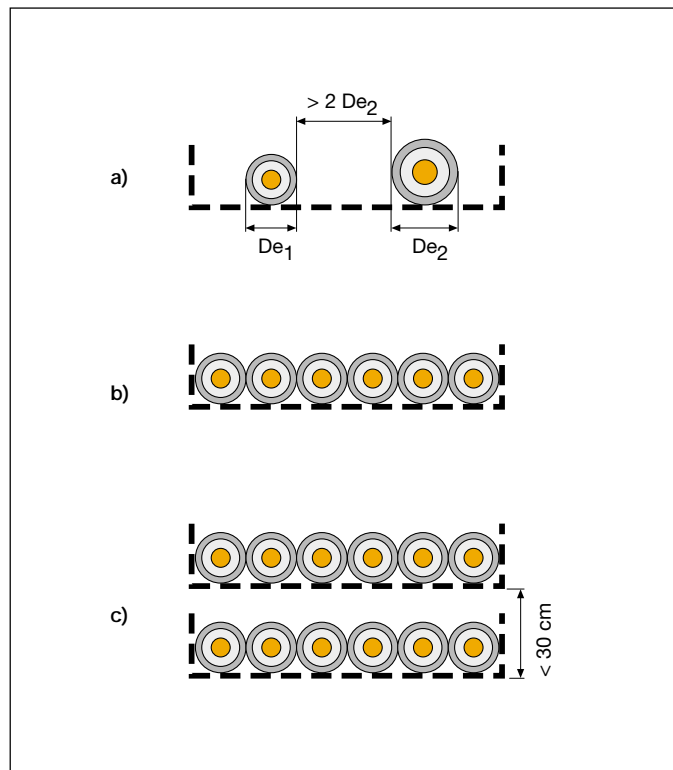

Cables in layers: a) spaced; b) not spaced; c) double layer

*bunch*: several circuits constituted by cables that are not spaced and are not installed in a layer; several layers superimposed on a single support (e.g. tray) are considered to be a bunch.

## 2 Protection of feeders

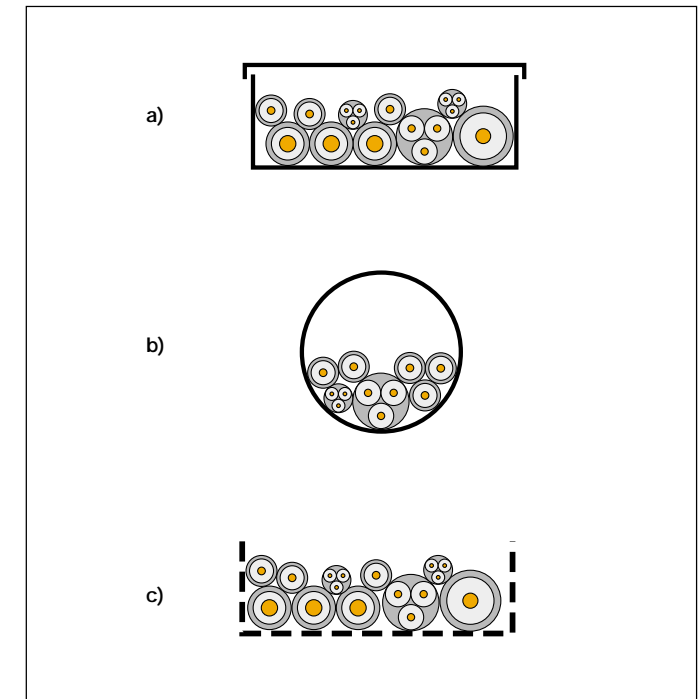

Bunched cables: a) in trunking; b) in conduit; c) on perforated tray

The value of correction factor  $k_2$  is 1 when:

- the cables are spaced:
  - two single-core cables belonging to different circuits are spaced when the distance between them is more than twice the external diameter of the cable with the larger cross section;
  - two multi-core cables are spaced when the distance between them is at least the same as the external diameter of the larger cable;
- the adjacent cables are loaded less than 30 % of their current carrying capacity.

The correction factors for bunched cables or cables in layers are calculated by assuming that the bunches consist of similar cables that are equally loaded. A group of cables is considered to consist of similar cables when the calculation of the current carrying capacity is based on the same maximum allowed operating temperature and when the cross sections of the conductors is in the range of three adjacent standard cross sections (e.g. from 10 to 25 mm<sup>2</sup>).

The calculation of the reduction factors for bunched cables with different cross sections depends on the number of cables and on their cross sections. These factors have not been tabled, but must be calculated for each bunch or layer.

## 2 Protection of feeders

The reduction factor for a group containing different cross sections of insulated conductors or cables in conduits, cable trunking or cable ducting is:

$$k_2 = \frac{1}{\sqrt{n}}$$

where:

- $k_2$  is the group reduction factor;
- $n$  is the number of circuits of the bunch.

The reduction factor obtained by this equation reduces the danger of overloading of cables with a smaller cross section, but may lead to under utilization of cables with a larger cross section. Such under utilization can be avoided if large and small cables are not mixed in the same group.

The following tables show the reduction factor ( $k_2$ ).

**Table 5: Reduction factor for grouped cables**

Item	Arrangement (cables touching)	Number of circuits or multi-core cables												To be used with current-carrying capacities, reference
		1	2	3	4	5	6	7	8	9	12	16	20	
1	Bunched in air, on a surface, embedded or enclosed	1.00	0.80	0.70	0.65	0.60	0.57	0.54	0.52	0.50	0.45	0.41	0.38	Methods A to F
2	Single layer on wall, floor or unperforated tray	1.00	0.85	0.79	0.75	0.73	0.72	0.72	0.71	0.70				
3	Single layer fixed directly under a wooden ceiling	0.95	0.81	0.72	0.68	0.66	0.64	0.63	0.62	0.61	No further reduction factor for more than nine circuits or multicore cables	Method C		
4	Single layer on a perforated horizontal or vertical tray	1.00	0.88	0.82	0.77	0.75	0.73	0.73	0.72	0.72				
5	Single layer on ladder support or cleats etc.	1.00	0.87	0.82	0.80	0.80	0.79	0.79	0.78	0.78	Methods E and F			

NOTE 1 These factors are applicable to uniform groups of cables, equally loaded.

NOTE 2 Where horizontal clearances between adjacent cables exceeds twice their overall diameter, no reduction factor need be applied.

NOTE 3 The same factors are applied to:

- groups of two or three single-core cables;
- multi-core cables.

NOTE 4 If a system consists of both two- and three-core cables, the total number of cables is taken as the number of circuits, and the corresponding factor is applied to the tables for two loaded conductors for the two-core cables, and to the tables for three loaded conductors for the three-core cables.

NOTE 5 If a group consists of  $n$  single-core cables it may either be considered as  $n/2$  circuits of two loaded conductors or  $n/3$  circuits of three loaded conductors.

## 2 Protection of feeders

**Table 6: Reduction factor for single-core cables with method of installation F**

Method of installation in Table 3			Number of trays	Number of three-phase circuits (note 4)			Use as a multiplier to rating for
				1	2	3	
Perforated trays (note 2)	31		1	0.98	0.91	0.87	Three cables in horizontal formation
			2	0.96	0.87	0.81	
			3	0.95	0.85	0.78	
Vertical perforated trays (note 3)	31		1	0.96	0.86	-	Three cables in vertical formation
			2	0.95	0.84	-	
Ladder supports, cleats, etc. (note 2)	32 33 34		1	1.00	0.97	0.96	Three cables in horizontal formation
			2	0.98	0.93	0.89	
			3	0.97	0.90	0.86	
Perforated trays (note 2)	31		1	1.00	0.98	0.96	
			2	0.97	0.93	0.89	
			3	0.96	0.92	0.86	
Vertical perforated trays (note 3)	31		1	1.00	0.91	0.89	Three cables in trefoil formation
			2	1.00	0.90	0.86	
Ladder supports, cleats, etc. (note 2)	32 33 34		1	1.00	1.00	1.00	
			2	0.97	0.95	0.93	
			3	0.96	0.94	0.90	

NOTE 1 Factors are given for single layers of cables (or trefoil groups) as shown in the table and do not apply when cables are installed in more than one layer touching each other. Values for such installations may be significantly lower and must be determined by an appropriate method.

NOTE 2 Values are given for vertical spacings between trays of 300 mm. For closer spacing the factors should be reduced.

NOTE 3 Values are given for horizontal spacing between trays of 225 mm with trays mounted back to back and at least 20 mm between the tray and any wall. For closer spacing the factors should be reduced.

NOTE 4 For circuits having more than one cable in parallel per phase, each three phase set of conductors should be considered as a circuit for the purpose of this table.

## 2 Protection of feeders

**Table 7: Reduction factor for multi-core cables with method of installation E**

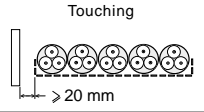
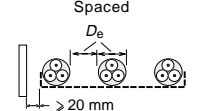
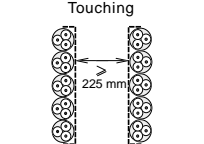
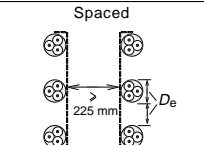
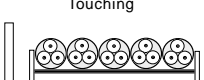
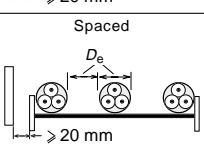
Method of installation in Table 3			Number of trays	Number of cables					
				1	2	3	4	6	9
Perforated trays (note 2)	31	 <p>Touching ≥ 20 mm</p>	1	1.00	0.88	0.82	0.79	0.76	0.73
			2	1.00	0.87	0.80	0.77	0.73	0.68
			3	1.00	0.86	0.79	0.76	0.71	0.66
		 <p>Spaced <math>D_e</math> ≥ 20 mm</p>	1	1.00	1.00	0.98	0.95	0.91	–
			2	1.00	0.99	0.96	0.92	0.87	–
			3	1.00	0.98	0.95	0.91	0.85	–
Vertical perforated trays (note 3)	31	 <p>Touching 225 mm</p>	1	1.00	0.88	0.82	0.78	0.73	0.72
			2	1.00	0.88	0.81	0.76	0.71	0.70
		 <p>Spaced 225 mm <math>D_e</math></p>	1	1.00	0.91	0.89	0.88	0.87	–
			2	1.00	0.91	0.88	0.87	0.85	–
			3	1.00	0.91	0.88	0.87	0.85	–
			3	1.00	0.91	0.88	0.87	0.85	–
Ladder supports, cleats, etc. (note 2)	32	 <p>Touching ≥ 20 mm</p>	1	1.00	0.87	0.82	0.80	0.79	0.78
			2	1.00	0.86	0.80	0.78	0.76	0.73
			3	1.00	0.85	0.79	0.76	0.73	0.70
	33 34	 <p>Spaced <math>D_e</math> ≥ 20 mm</p>	1	1.00	1.00	1.00	1.00	1.00	–
			2	1.00	0.99	0.98	0.97	0.96	–
			3	1.00	0.98	0.97	0.96	0.93	–

NOTE 1 Factors apply to single layer groups of cables as shown above and do not apply when cables are installed in more than one layer touching each other. Values for such installations may be significantly lower and must be determined by an appropriate method.

NOTE 2 Values are given for vertical spacings between trays of 300 mm and at least 20 mm between trays and wall. For closer spacing the factors should be reduced.

NOTE 3 Values are given for horizontal spacing between trays of 225 mm with trays mounted back to back. For closer spacing the factors should be reduced.

1SDC010005F0201

## 2 Protection of feeders

To summarize:

The following procedure shall be used to determine the cross section of the cable:

- from Table 3 identify the method of installation;
- from Table 4 determine the correction factor  $k_1$  according to insulation material and ambient temperature;
- use Table 5 for cables installed in layer or bunch, Table 6 for single-core cables in a layer on several supports, Table 7 for multi-core cables in a layer on several supports or the formula shown in the case of groups of cables with different sections to determine the correction factor  $k_2$  appropriate for the numbers of circuits or multi-core cables;
- calculate the value of current  $I'_b$  by dividing the load current  $I_b$  (or the rated current of the protective device) by the product of the correction factors calculated:

$$I'_b = \frac{I_b}{k_1 k_2} = \frac{I_b}{k_{tot}}$$

- from Table 8 or from Table 9, depending on the method of installation, on insulation and conductive material and on the number of live conductors, determine the cross section of the cable with capacity  $I_0 \geq I'_b$ ;

- the actual cable current carrying capacity is calculated by  $I_z = I_0 k_1 k_2$ .

## 2 Protection of feeders

Table 8: Current carrying capacity of cables with PVC or EPR/XLPE insulation (method A-B-C)

Installation method	A1								A2								B1								B2								C								
	Conductor				Conductor				Conductor				Conductor				Conductor				Conductor																				
Insulation	Cu		Al		Cu		Al		Cu		Al		Cu		Al		Cu		Al		Cu		Al																		
	XLPE EPR	PVC	XLPE EPR	PVC	XLPE EPR	PVC	XLPE EPR	PVC	XLPE EPR	PVC	XLPE EPR	PVC	XLPE EPR	PVC	XLPE EPR	PVC	XLPE EPR	PVC	XLPE EPR	PVC	XLPE EPR	PVC	XLPE EPR	PVC																	
S[mm <sup>2</sup> ]	Loaded conductors		Loaded conductors		Loaded conductors		Loaded conductors		Loaded conductors		Loaded conductors		Loaded conductors		Loaded conductors		Loaded conductors		Loaded conductors		Loaded conductors		Loaded conductors																		
	2	3	2	3	2	3	2	3	2	3	2	3	2	3	2	3	2	3	2	3	2	3	2	3																	
1.5	19	17	14.5	13.5					18.5	16.5	14	13					23	20	17.5	15.5					24	22	19.5	17.5													
2.5	26	23	19.5	18	20	19	15	14	25	22	18.5	17.5	19.5	18	14.5	13.5	31	28	24	21	25	22	18.5	16.5	30	26	23	20	23	21	17.5	15.5	33	30	27	24	26	24	21	18.5	
4	35	31	26	24	27	25	20	18.5	33	30	25	23	26	24	19.5	17.5	42	37	32	28	33	29	25	22.0	40	35	30	27	31	28	24	21	45	40	36	32	35	32	28	25	
6	45	40	34	31	35	32	26	24	42	38	32	29	33	31	25	23	54	48	41	36	43	38	32	28	51	44	38	34	40	35	30	27.0	58	52	46	41	45	41	36	32	
10	61	54	46	42	48	44	36	32	57	51	43	39	45	41	33	31	75	66	57	50	59	52	44	39	69	60	52	46	54	48	41	36	80	71	63	57	62	57	49	44	
16	81	73	61	56	64	58	48	43	76	68	57	52	60	55	44	41	100	88	76	68	79	71	60	53	91	80	69	62	72	64	54	48	107	96	85	76	84	76	66	59	
25	106	95	80	73	84	76	63	57	99	89	75	68	78	71	58	53	133	117	101	89	105	93	79	70	119	105	90	80	94	84	71	62	138	119	112	96	101	90	83	73	
35	131	117	99	89	103	94	77	70	121	109	92	83	96	87	71	65	164	144	125	110	130	116	97	86	146	128	111	99	115	103	86	77	171	147	138	119	126	112	103	90	
50	158	141	119	108	125	113	93	84	145	130	110	99	115	104	86	78	198	175	151	134	157	140	118	104	175	154	133	118	138	124	104	92	209	179	168	144	154	136	125	110	
70	200	179	151	136	158	142	118	107	183	164	139	125	145	131	108	98	253	222	192	171	200	179	150	133	221	194	168	149	175	156	131	116	269	229	213	184	198	174	160	140	
95	241	216	182	164	191	171	142	129	220	197	167	150	175	157	130	118	306	269	232	207	242	217	181	161	265	233	201	179	210	188	157	139	328	278	258	223	241	211	195	170	
120	278	249	210	188	220	197	164	149	253	227	192	172	201	180	150	135	354	312	269	239	281	251	210	186	305	268	232	206	242	216	181	160	382	322	299	259	280	245	226	197	
150	318	285	240	216	253	226	189	170	290	259	219	196	230	206	172	155																									
185	362	324	273	245	288	256	215	194	329	295	248	223	262	233	195	176																									
240	424	380	321	286	338	300	252	227	386	346	291	261	307	273	229	207																									
300	486	435	367	328	387	344	289	261	442	396	334	298	352	313	263	237																									
400																																									
500																																									
630																																									

1SDC010006F0201



## 2 Protection of feeders

## 2 Protection of feeders

Table 8: Current carrying capacity of cables with PVC or EPR/XLPE insulation (method E-F-G)

S[mm <sup>2</sup> ]	Installation method	E								F								G										
		Cu		Al		Cu		Al		Cu		Al		Cu		Al		Cu		Al		Cu		Al				
XLPE		XLPE		XLPE		XLPE		XLPE		XLPE		XLPE		XLPE		XLPE		XLPE		XLPE		XLPE						
EPR		EPR		EPR		EPR		EPR		EPR		EPR		EPR		EPR		EPR		EPR		EPR						
PVC		PVC		PVC		PVC		PVC		PVC		PVC		PVC		PVC		PVC		PVC		PVC						
Loaded conductors		2		3		2		3		3		3H		3V		3H		3V		3H		3V						
1.5	26	22			23	18.5																						
2.5	36	30	28	23	32	25	24	19.5																				
4	49	40	38	31	42	34	32	26																				
6	63	51	49	39	54	43	42	33																				
10	86	70	67	54	75	60	58	46																				
16	115	94	91	73	100	80	77	61																				
25	149	119	108	89	127	101	97	78	161	131	121	98	135	110	103	84	141	114	107	87	182	161	146	130	138	122	112	99
35	185	148	135	111	158	126	120	96	200	162	150	122	169	137	129	105	176	143	135	109	226	201	181	162	172	153	139	124
50	225	180	164	135	192	153	146	117	242	196	184	149	207	167	159	128	216	174	165	133	275	246	219	197	210	188	169	152
70	289	232	211	173	246	196	187	150	310	251	237	192	268	216	206	166	279	225	215	173	353	318	281	254	271	244	217	196
95	352	282	257	210	298	238	227	183	377	304	289	235	328	264	253	203	342	275	264	212	430	389	341	311	332	300	265	241
120	410	328	300	244	346	276	263	212	437	352	337	273	383	308	296	237	400	321	308	247	500	454	396	362	387	351	308	282
150	473	379	346	282	399	319	304	245	504	406	389	316	444	356	343	274	464	372	358	287	577	527	456	419	448	408	356	327
185	542	434	397	322	456	364	347	280	575	463	447	363	510	409	395	315	533	427	413	330	661	605	521	480	515	470	407	376
240	641	514	470	380	538	430	409	330	679	546	530	430	607	485	471	375	634	507	492	392	781	719	615	569	611	561	482	447
300	741	593	543	439	621	497	471	381	783	629	613	497	703	561	547	434	736	587	571	455	902	833	709	659	708	652	557	519
400									940	754	740	600	823	656	663	526	868	689	694	552	1085	1008	852	795	856	792	671	629
500									1083	868	856	694	946	749	770	610	998	789	806	640	1253	1169	982	920	991	921	775	730
630									1254	1005	996	808	1088	855	899	711	1151	905	942	746	1454	1362	1138	1070	1154	1077	900	852

1SDC010100F0201

## 2 Protection of feeders

Table 9: Current carrying capacity of cables with mineral insulation

	Installation method	C						E or F						G				
		Metallic sheath temperature 70 °C			Metallic sheath temperature 105 °C			Metallic sheath temperature 70 °C			Metallic sheath temperature 105 °C			Metallic sheath temperature 70 °C		Metallic sheath temperature 105 °C		
		PVC covered or bare exposed to touch			Bare cable not exposed to touch			PVC covered or bare exposed to touch			Bare cable not exposed to touch			PVC covered or bare exposed to touch		Bare cable not exposed to touch		
Loaded conductors																		
	S[mm <sup>2</sup> ]	2	3	3	2	3	3	2	3	3	2	3	3	2	3	3	3	3
500 V	1.5	23	19	21	28	24	27	25	21	23	31	26	29	26	29	33	37	
	2.5	31	26	29	38	33	36	33	28	31	41	35	39	34	39	43	49	
	4	40	35	38	51	44	47	44	37	41	54	46	51	45	51	56	64	
	6	45	37	41	55	47	53	47	40	45	60	50	56	49	56	61	70	
750 V	1.5	25	21	23	31	26	30	26	22	26	33	28	32	28	32	35	40	
	2.5	34	28	31	42	35	41	36	30	34	45	38	43	37	43	47	54	
	4	45	37	41	55	47	53	47	40	45	60	50	56	49	56	61	70	
	6	57	48	52	70	59	67	60	51	57	76	64	71	62	71	78	89	
	10	77	65	70	96	81	91	82	69	77	104	87	96	84	95	105	120	
	16	102	86	92	127	107	119	109	92	102	137	115	127	110	125	137	157	
	25	133	112	120	166	140	154	142	120	132	179	150	164	142	162	178	204	
	35	163	137	147	203	171	187	174	147	161	220	184	200	173	197	216	248	
	50	202	169	181	251	212	230	215	182	198	272	228	247	213	242	266	304	
	70	247	207	221	307	260	280	264	223	241	333	279	300	259	294	323	370	
	95	296	249	264	369	312	334	317	267	289	400	335	359	309	351	385	441	
	120	340	286	303	424	359	383	364	308	331	460	385	411	353	402	441	505	
	150	388	327	346	485	410	435	416	352	377	526	441	469	400	454	498	565	
	185	440	371	392	550	465	492	472	399	426	596	500	530	446	507	557	629	
	240	514	434	457	643	544	572	552	466	496	697	584	617	497	565	624	704	

- Note 1 For single-core cables the sheaths of the cables of the circuit are connected together at both ends.
- Note 2 For bare cables exposed to touch, values should be multiplied by 0.9.
- Note 3  $D_e$  is the external diameter of the cable.
- Note 4 For metallic sheath temperature 105 °C no correction for grouping need to be applied.

1SDC010007F0201

## 2 Protection of feeders

### Installation in ground: choice of the cross section according to cable carrying capacity and type of installation

The current carrying capacity of a cable buried in the ground is calculated by using this formula:

$$I_z = I_0 k_1 k_2 k_3 = I_0 k_{tot}$$

where:

- $I_0$  is the current carrying capacity of the single conductor for installation in the ground at 20°C reference temperature;
- $k_1$  is the correction factor if the temperature of the ground is other than 20°C;
- $k_2$  is the correction factor for adjacent cables;
- $k_3$  is the correction factor if the soil thermal resistivity is different from the reference value, 2.5 Km/W.

#### Correction factor $k_1$

The current carrying capacity of buried cables refers to a ground temperature of 20 °C. If the ground temperature is different, use the correction factor  $k_1$  shown in Table 10 according to the insulation material.

**Table 10: Correction factors for ambient ground temperatures other than 20 °C**

Ground temperature °C	Insulation	
	PVC	XLPE and EPR
10	1.10	1.07
15	1.05	1.04
25	0.95	0.96
30	0.89	0.93
35	0.84	0.89
40	0.77	0.85
45	0.71	0.80
50	0.63	0.76
55	0.55	0.71
60	0.45	0.65
65	-	0.60
70	-	0.53
75	-	0.46
80	-	0.38

## 2 Protection of feeders

### Correction factor $k_2$

The cable current carrying capacity is influenced by the presence of other cables installed nearby. The heat dissipation of a single cable is different from that of the same cable installed next to the other ones.

The correction factor  $k_2$  is obtained by the formula:

$$k_2 = k_2' \cdot k_2''$$

Tables 11, 12, and 13 show the factor  $k_2'$  values for single-core and multi-core cables that are laid directly in the ground or which are installed in buried ducts, according to their distance from other cables or the distance between the ducts.

**Table 11: Reduction factors for cables laid directly in the ground**

Number of circuits	Cable to cable clearance (a)				
	Nil (cables touching)	One cable diameter	0.125 m	0.25 m	0.5 m
2	0.75	0.80	0.85	0.90	0.90
3	0.65	0.70	0.75	0.80	0.85
4	0.60	0.60	0.70	0.75	0.80
5	0.55	0.55	0.65	0.70	0.80
6	0.50	0.55	0.60	0.70	0.80

Multi-core cables



Single-core cables



NOTE The given values apply to an installation depth of 0.7 m and a soil thermal resistivity of 2.5 Km/W.

## 2 Protection of feeders

**Table 12: Reduction factors for multi-core cables laid in single way ducts in the ground**

Number of circuits	Cable to cable clearance (a)			
	Nil (cables touching)	0.25 m	0.5 m	1.0 m
2	0.85	0.90	0.95	0.95
3	0.75	0.85	0.90	0.95
4	0.70	0.80	0.85	0.90
5	0.65	0.80	0.85	0.90
6	0.60	0.80	0.80	0.90

Multi-core cables

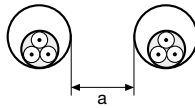

NOTE The given values apply to an installation depth of 0.7 m and a soil thermal resistivity of 2.5 Km/W.

**Table 13: Reduction factors for single-core cables laid in single way ducts in the ground**

Number of single-core circuits of two or three cables	Duct to duct clearance (a)			
	Nil (ducts touching)	0.25 m	0.5 m	1.0 m
2	0.80	0.90	0.90	0.95
3	0.70	0.80	0.85	0.90
4	0.65	0.75	0.80	0.90
5	0.60	0.70	0.80	0.90
6	0.60	0.70	0.80	0.90

Single-core cables

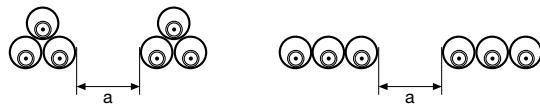

NOTE The given values apply to an installation depth of 0.7 m and a soil thermal resistivity of 2.5 Km/W.

## 2 Protection of feeders

For correction factor  $k_2''$ :

- for cables laid directly in the ground or if there are not other conductors within the same duct, the value of  $k_2''$  is 1;
- if several conductors of similar sizes are present in the same duct (for the meaning of "group of similar conductors", see the paragraphs above),  $k_2''$  is obtained from the first row of Table 5;
- if the conductors are not of similar size, the correction factor is calculated by using this formula:

$$k_2'' = \frac{1}{\sqrt{n}}$$

where:

n is the number of circuits in the duct.

### Correction factor $k_3$

Soil thermal resistivity influences the heat dissipation of the cable. Soil with low thermal resistivity facilitates heat dissipation, whereas soil with high thermal resistivity limits heat dissipation. IEC 60364-5-52 states as reference value for the soil thermal resistivity 2.5 Km/W.

**Table 14: Correction factors for soil thermal resistivities other than 2.5 Km/W**

Thermal resistivities Km/W	1	1.5	2	2.5	3
Correction factor	1.18	1.1	1.05	1	0.96

Note 1: the overall accuracy of correction factors is within ±5%.

Note 2: the correction factors are applicable to cables drawn into buried ducts; for cables laid direct in the ground the correction factors for thermal resistivities less than 2.5 Km/W will be higher. Where more precise values are required they may be calculated by methods given in IEC 60287.

Note 3: the correction factors are applicable to ducts buried at depths of up to 0.8 m.

## 2 Protection of feeders

To summarize:

Use this procedure to determine the cross section of the cable:

- from Table 10, determine the correction factor  $k_1$  according to the insulation material and the ground temperature;
- use Table 11, Table 12, Table 13 or the formula for groups of non-similar cables to determine the correction factor  $k_2$  according to the distance between cables or ducts;
- from Table 14 determine factor  $k_3$  corresponding to the soil thermal resistivity;
- calculate the value of the current  $I'_b$  by dividing the load current  $I_b$  (or the rated current of the protective device) by the product of the correction factors calculated:

$$I'_b = \frac{I_b}{k_1 k_2 k_3} = \frac{I_b}{K_{tot}}$$

- from Table 15, determine the cross section of the cable with  $I_0 \geq I'_b$ , according to the method of installation, the insulation and conductive material and the number of live conductors;

- the actual cable current carrying capacity is calculated by.

$$I_z = I_0 k_1 k_2 k_3$$

Table 15: Current carrying capacity of cables buried in the ground

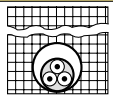
S [mm <sup>2</sup> ]	Installation method	D							
									
	Conductor	Cu				Al			
		XLPE EPR		PVC		XLPE EPR		PVC	
Loaded conductors	2	3	2	3	2	3	2	3	
1.5	26	22	22	18	26	22	22	18.5	
2.5	34	29	29	24	34	29	29	24	
4	44	37	38	31	44	37	37	30	
6	56	46	47	39	56	46	46	36	
10	73	61	63	52	73	61	61	48	
16	95	79	81	67	95	79	79	62	
25	121	101	104	86	121	101	101	80	
35	146	122	125	103	146	122	122	96	
50	173	144	148	122	173	144	144	113	
70	213	178	183	151	213	178	178	140	
95	252	211	216	179	252	211	211	166	
120	287	240	246	203	287	240	240	189	
150	324	271	278	230	324	271	271	213	
185	363	304	312	258	363	304	304	240	
240	419	351	361	297	419	351	351	277	
300	474	396	408	336	474	396	396	313	

1SDC010008F0201

## 2 Protection of feeders

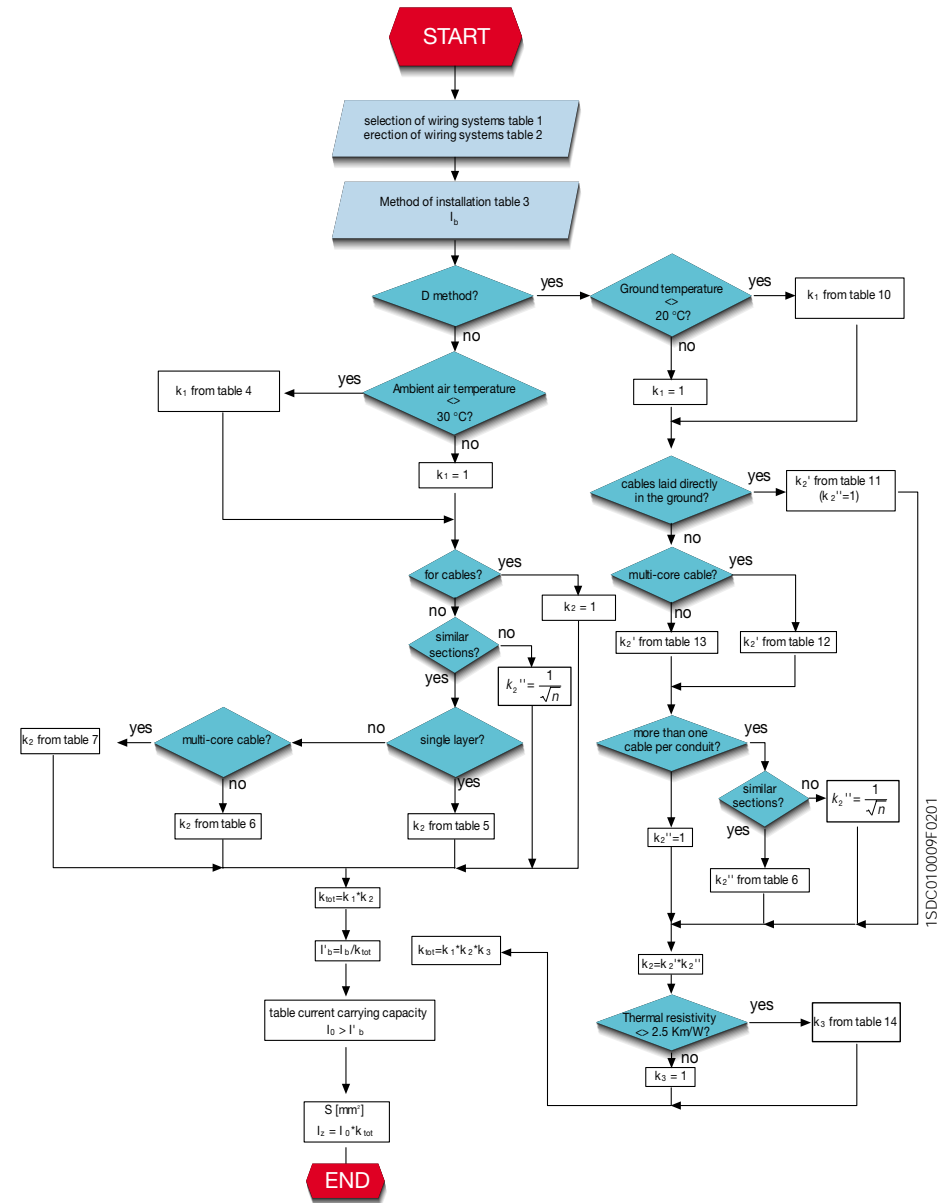

1SDC010009F0201

## 2 Protection of feeders

### Note on current carrying capacity tables and loaded conductors

Tables 8, 9 and 15 provide the current carrying capacity of loaded conductors (current carrying conductors) under normal service conditions.

In single-phase circuits, the number of loaded conductors is two.

In balanced or slightly unbalanced three-phase circuits the number of loaded conductors is three, since the current in the neutral conductor is negligible.

In three-phase systems with high unbalance, where the neutral conductor in a multi-core cable carries current as a result of an unbalance in the phase currents the temperature rise due to the neutral current is offset by the reduction in the heat generated by one or more of the phase conductors. In this case the conductor size shall be chosen on the basis of the highest phase current. In all cases the neutral conductor shall have an adequate cross section.

### Effect of harmonic currents on balanced three-phase systems: reduction factors for harmonic currents in four-core and five-core cables with four cores carrying current

Where the neutral conductor carries current without a corresponding reduction in load of the phase conductors, the current flowing in the neutral conductor shall be taken into account in ascertaining the current-carrying capacity of the circuit.

This neutral current is due to the phase currents having a harmonic content which does not cancel in the neutral. The most significant harmonic which does not cancel in the neutral is usually the third harmonic. The magnitude of the neutral current due to the third harmonic may exceed the magnitude of the power frequency phase current. In such a case the neutral current will have a significant effect on the current-carrying capacity of the cables in the circuit.

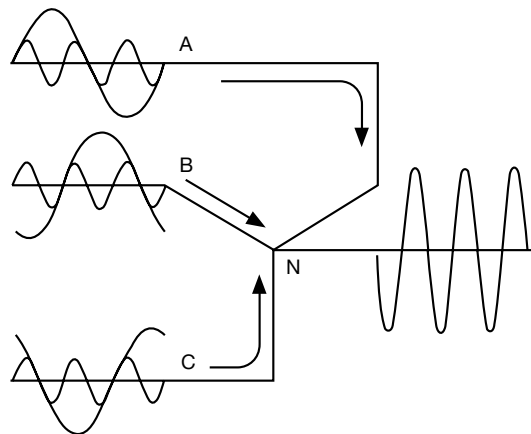

1SDC010007F0001

## 2 Protection of feeders

Equipment likely to cause significant harmonic currents are, for example, fluorescent lighting banks and dc power supplies such as those found in computers (for further information on harmonic disturbances see the IEC 61000). The reduction factors given in Table 16 only apply in the balanced three-phase circuits (the current in the fourth conductor is due to harmonics only) to cables where the neutral conductor is within a four-core or five-core cable and is of the same material and cross-sectional area as the phase conductors. These reduction factors have been calculated based on third harmonic currents. If significant, i.e. more than 10 %, higher harmonics (e.g. 9th, 12th, etc.) are expected or there is an unbalance between phases of more than 50 %, then lower reduction factors may be applicable: these factors can be calculated only by taking into account the real shape of the current in the loaded phases.

Where the neutral current is expected to be higher than the phase current then the cable size should be selected on the basis of the neutral current.

Where the cable size selection is based on a neutral current which is not significantly higher than the phase current, it is necessary to reduce the tabulated current carrying capacity for three loaded conductors.

If the neutral current is more than 135 % of the phase current and the cable size is selected on the basis of the neutral current, then the three phase conductors will not be fully loaded. The reduction in heat generated by the phase conductors offsets the heat generated by the neutral conductor to the extent that it is not necessary to apply any reduction factor to the current carrying capacity for three loaded conductors.

**Table 16: Reduction factors for harmonic currents in four-core and five-core cables**

Third harmonic content of phase current	Reduction factor			
	Size selection is based on phase current	Current to take in account for the cable selection $I'_b$	Size selection is based on neutral current	Current to take in account for the cable selection $I'_b$
0 ÷ 15	1	$I'_b = \frac{I_b}{k_{tot}}$	-	-
15 ÷ 33	0.86	$I'_b = \frac{I_b}{k_{tot} \cdot 0.86}$	-	-
33 ÷ 45	-	-	0.86	$I'_b = \frac{I_N}{0.86}$
> 45	-	-	1	$I'_b = I_N$

Where  $I_N$  is the current flowing in the neutral calculated as follows:  $I_N = \frac{I_b}{k_{tot}} \cdot 3 \cdot k_{III}$

$I_b$  is the load current;

$k_{tot}$  is the total correction factor;

$k_{III}$  is the third harmonic content of phase current;

## 2 Protection of feeders

### Example of cable dimensioning in a balanced three-phase circuit without harmonics

Dimensioning of a cable with the following characteristics:

- conductor material: : copper
- insulation material: : PVC
- type of cable: : multi-core
- installation: : cables bunched on horizontal perforated tray
- load current: : 100 A

Installation conditions:

- ambient temperature: : 40 °C
- adjacent circuits with
  - a) three-phase circuit consisting of 4 single-core cables, 4x50 mm<sup>2</sup>;
  - b) three-phase circuit consisting of one multi-core cable, 1x(3x50) mm<sup>2</sup>;
  - c) three-phase circuit consisting of 9 single-core (3 per phase) cables, 9x95 mm<sup>2</sup>;
  - d) single-phase circuit consisting of 2 single-core cables, 2x70 mm<sup>2</sup>.

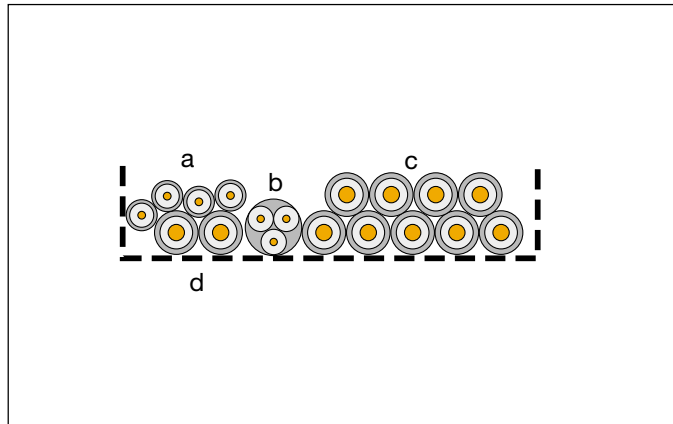

## 2 Protection of feeders

### Procedure:

Type of installation

In Table 3, it is possible to find the reference number of the installation and the method of installation to be used for the calculations. In this example, the reference number is 31, which corresponds to method E (multi-core cable on tray).

Correction factor of temperature  $k_1$

From Table 4, for a temperature of 40 °C and PVC insulation material,  $k_1 = 0.87$ .

$$k_1 = 0.87$$

Correction factor for adjacent cables  $k_2$

For the multi-core cables grouped on the perforated tray see Table 5. As a first step, the number of circuits or multi-core cables present shall be determined: given that:

- each circuit a), b) and d) constitute a separate circuit;
  - circuit c) consists of three circuits, since it is composed by three cables in parallel per phase;
  - the cable to be dimensioned is a multi-core cable and therefore constitutes a single circuit;
- the total number of circuits is 7.  
Referring to the row for the arrangement (cables bunched) and to the column for the number of circuits (7)

$$k_2 = 0.54$$

After  $k_1$  and  $k_2$  have been determined,  $I'_b$  is calculated by:

$$I'_b = \frac{I_b}{k_1 k_2} = \frac{100}{0.87 \cdot 0.54} = 212.85 \text{ A}$$

From Table 8, for a multi-core copper cable with PVC insulation, method of installation E, with three loaded conductors, a cross section with current carrying capacity of  $I_0 \geq I'_b = 212.85 \text{ A}$ , is obtained. A 95 mm<sup>2</sup> cross section cable can carry, under Standard reference conditions, 238 A.

The current carrying capacity, according to the actual conditions of installation, is  $I_z = 238 \cdot 0.87 \cdot 0.54 = 111.81 \text{ A}$

## 2 Protection of feeders

### Example of dimensioning a cable in a balanced three-phase circuit with a significant third-harmonic content

*Dimensioning of a cable with the following characteristics:*

- conductor material: : copper
- insulation material: : PVC
- type of cable: : multi-core
- installation: : layer on horizontal perforated tray
- load current: : 115 A

*Installation conditions:*

- ambient temperature: : 30 °C
- no adjacent circuits.

#### Procedure:

*Type of installation*

On Table 3, it is possible to find the reference number of the installation and the method of installation to be used for the calculations. In this example, the reference number is 31, which corresponds to method E (multi-core cable on tray).

*Temperature correction factor  $k_1$*

From Table 4, for a temperature of 30 °C and PVC insulation material

$$k_1 = 1$$

*Correction factor for adjacent cables  $k_2$*

As there are no adjacent cables, so

$$k_2 = 1$$

After  $k_1$  and  $k_2$  have been determined,  $I'_b$  is calculated by:

$$I'_b = \frac{I_b}{k_1 k_2} = 115 \text{ A}$$

## 2 Protection of feeders

If no harmonics are present, from Table 8, for a multi-core copper cable with PVC insulation, method of installation E, with three loaded conductors, a cross section with current carrying capacity of  $I_0 \geq I'_b = 115 \text{ A}$ , is obtained. A 35 mm<sup>2</sup> cross section cable can carry, under Standard reference conditions, 126 A. The current carrying capacity, according to the actual conditions of installation, is still 126 A, since the value of factors  $k_1$  and  $k_2$  is 1.

The third harmonic content is assumed to be 28%.

Table 16 shows that for a third harmonic content of 28% the cable must be dimensioned for the current that flows through the phase conductors, but a reduction factor of 0.86 must be applied. The current  $I'_b$  becomes:

$$I'_b = \frac{I_b}{k_1 \cdot k_2 \cdot 0.86} = \frac{115}{0.86} = 133.7 \text{ A}$$

From Table 8, a 50 mm<sup>2</sup> cable with carrying capacity of 153 A shall be selected.

If the third harmonic content is 40 %, Table 16 shows that the cable shall be dimensioned according to the current of the neutral conductor and a reduction factor of 0.86 must be applied.

The current in the neutral conductor is:

$$I_N = \frac{I_b}{k_{\text{tot}}} \cdot 3 \cdot k_{\text{III}} = 115 \cdot 3 \cdot 0.4 = 138 \text{ A}$$

and the value of current  $I'_b$  is:

$$I'_b = \frac{I_N}{0.86} = \frac{138}{0.86} = 160.5 \text{ A}$$

From Table 8, a 70 mm<sup>2</sup> cable with 196 A current carrying capacity shall be selected.

If the third harmonic content is 60 %, Table 16 shows that the cable shall be dimensioned according to the current of the neutral conductor, but a reduction factor of 1 must be applied.

The current in the neutral conductor is:

$$I_N = \frac{I_b}{k_{\text{tot}}} \cdot 3 \cdot k_{\text{III}} = 115 \cdot 3 \cdot 0.6 = 207 \text{ A}$$

and current  $I'_b$  is:

$$I'_b = I_N = 207 \text{ A}$$

From Table 8, a 95 mm<sup>2</sup> cable with current carrying capacity of 238 A must be selected.



## 2 Protection of feeders

### 2.2.2 Voltage drop

In an electrical installation it is important to evaluate voltage drops from the point of supply to the load.

The performance of a device may be impaired if supplied with a voltage different from its rated voltage. For example:

- *motors*: the torque is proportional to the square of the supply voltage; therefore, if the voltage drops, the starting torque shall also decrease, making it more difficult to start up motors; the maximum torque shall also decrease;
- *incandescent lamps*: the more the voltage drops the weaker the beam becomes and the light takes on a reddish tone;
- *discharge lamps*: in general, they are not very sensitive to small variations in voltage, but in certain cases, great variation may cause them to switch off;
- *electronic appliances*: they are very sensitive to variations in voltage and that is why they are fitted with stabilizers;
- *electromechanical devices*: the reference Standard states that devices such as contactors and auxiliary releases have a minimum voltage below which their performances cannot be guaranteed. For a contactor, for example, the holding of the contacts becomes unreliable below 85% of the rated voltage.

To limit these problems the Standards set the following limits:

- IEC 60364-5-52 "Electrical installations of buildings. Selection and erection of electrical equipment - Wiring systems" Clause 525 states that "in the absence of other considerations it is recommended that in practice the voltage drop between the origin of consumer's installation and the equipment should not be greater than 4% of the rated voltage of the installation. Other considerations include start-up time for motors and equipment with high inrush current. Temporary conditions such as voltage transients and voltage variation due to abnormal operation may be disregarded".
- IEC 60204-1 "Safety of machinery - Electrical equipment of machines - General requirements" Clause 13.5 recommends that: "the voltage drop from the point of supply to the load shall not exceed 5% of the rated voltage under normal operating conditions".
- IEC 60364-7-714 "Electrical installations of buildings - Requirements for special installations or locations - External lighting installations" Clause 714.512 requires that "the voltage drop in normal service shall be compatible with the conditions arising from the starting current of the lamps".

## 2 Protection of feeders

### Voltage drop calculation

For an electrical conductor with impedance Z, the voltage drop is calculated by the following formula:

$$\Delta U = kZ I_b = k I_b \frac{L}{n} (r \cos \varphi + x \sin \varphi) \quad [V] \quad (1)$$

where

- k is a coefficient equal to:
  - 2 for single-phase and two-phase systems;
  - $\sqrt{3}$  for three-phase systems;
- $I_b$  [A] is the load current; if no information are available, the cable carrying capacity  $I_z$  shall be considered;
- L [km] is the length of the conductor;
- n is the number of conductors in parallel per phase;
- r [ $\Omega$ /km] is the resistance of the single cable per kilometre;
- x [ $\Omega$ /km] is the reactance of the single cable per kilometre;
- $\cos \varphi$  is the power factor of the load:  $\sin \varphi = \sqrt{1 - \cos^2 \varphi}$ .

Normally, the percentage value in relation to the rated value  $U_r$  is calculated by:

$$\Delta u \% = \frac{\Delta U}{U_r} 100 \quad (2)$$

Resistance and reactance values per unit of length are set out on the following table by cross-sectional area and cable formation, for 50 Hz; in case of 60 Hz, the reactance value shall be multiplied by 1.2.

## 2 Protection of feeders

Table 1: Resistance and reactance per unit of length of copper cables

S [mm <sup>2</sup> ]	single-core cable		two-core/three-core cable	
	r[Ω/km] @ 80 [°C]	x[Ω/km]	r[Ω/km] @ 80 [°C]	x[Ω/km]
1.5	14.8	0.168	15.1	0.118
2.5	8.91	0.156	9.08	0.109
4	5.57	0.143	5.68	0.101
6	3.71	0.135	3.78	0.0955
10	2.24	0.119	2.27	0.0861
16	1.41	0.112	1.43	0.0817
25	0.889	0.106	0.907	0.0813
35	0.641	0.101	0.654	0.0783
50	0.473	0.101	0.483	0.0779
70	0.328	0.0965	0.334	0.0751
95	0.236	0.0975	0.241	0.0762
120	0.188	0.0939	0.191	0.074
150	0.153	0.0928	0.157	0.0745
185	0.123	0.0908	0.125	0.0742
240	0.0943	0.0902	0.0966	0.0752
300	0.0761	0.0895	0.078	0.075

Table 2: Resistance and reactance per unit of length of aluminium cables

S [mm <sup>2</sup> ]	single-core cable		two-core/three-core cable	
	r[Ω/km] @ 80 [°C]	x[Ω/km]	r[Ω/km] @ 80 [°C]	x[Ω/km]
1.5	24.384	0.168	24.878	0.118
2.5	14.680	0.156	14.960	0.109
4	9.177	0.143	9.358	0.101
6	6.112	0.135	6.228	0.0955
10	3.691	0.119	3.740	0.0861
16	2.323	0.112	2.356	0.0817
25	1.465	0.106	1.494	0.0813
35	1.056	0.101	1.077	0.0783
50	0.779	0.101	0.796	0.0779
70	0.540	0.0965	0.550	0.0751
95	0.389	0.0975	0.397	0.0762
120	0.310	0.0939	0.315	0.074
150	0.252	0.0928	0.259	0.0745
185	0.203	0.0908	0.206	0.0742
240	0.155	0.0902	0.159	0.0752
300	0.125	0.0895	0.129	0.075

## 2 Protection of feeders

The following tables show the  $\Delta U_x$  [V/(A·km)] values by cross section and formation of the cable according to the most common  $\cos\phi$  values.

Table 3: Specific voltage drop at  $\cos\phi = 1$  for copper cables

S[mm <sup>2</sup> ]	$\cos\phi = 1$			
	single-core cable		two-core cable three-core cable	
	single-phase	three-phase	single-phase	three-phase
1.5	29.60	25.63	30.20	26.15
2.5	17.82	15.43	18.16	15.73
4	11.14	9.65	11.36	9.84
6	7.42	6.43	7.56	6.55
10	4.48	3.88	4.54	3.93
16	2.82	2.44	2.86	2.48
25	1.78	1.54	1.81	1.57
35	1.28	1.11	1.31	1.13
50	0.95	0.82	0.97	0.84
70	0.66	0.57	0.67	0.58
95	0.47	0.41	0.48	0.42
120	0.38	0.33	0.38	0.33
150	0.31	0.27	0.31	0.27
185	0.25	0.21	0.25	0.22
240	0.19	0.16	0.19	0.17
300	0.15	0.13	0.16	0.14

Table 4: Specific voltage drop at  $\cos\phi = 0.9$  for copper cables

S[mm <sup>2</sup> ]	$\cos\phi = 0.9$			
	single-core cable		two-core cable three-core cable	
	single-phase	three-phase	single-phase	three-phase
1.5	26.79	23.20	27.28	23.63
2.5	16.17	14.01	16.44	14.24
4	10.15	8.79	10.31	8.93
6	6.80	5.89	6.89	5.96
10	4.14	3.58	4.16	3.60
16	2.64	2.28	2.65	2.29
25	1.69	1.47	1.70	1.48
35	1.24	1.08	1.25	1.08
50	0.94	0.81	0.94	0.81
70	0.67	0.58	0.67	0.58
95	0.51	0.44	0.50	0.43
120	0.42	0.36	0.41	0.35
150	0.36	0.31	0.35	0.30
185	0.30	0.26	0.29	0.25
240	0.25	0.22	0.24	0.21
300	0.22	0.19	0.21	0.18

## 2 Protection of feeders

Table 5: Specific voltage drop at  $\cos\phi = 0.85$  for copper cables

S[mm <sup>2</sup> ]	$\cos\phi = 0.85$			
	single-core cable		two-core cable	three-core cable
	single-phase	three-phase	single-phase	three-phase
1.5	25.34	21.94	25.79	22.34
2.5	15.31	13.26	15.55	13.47
4	9.62	8.33	9.76	8.45
6	6.45	5.59	6.53	5.65
10	3.93	3.41	3.95	3.42
16	2.51	2.18	2.52	2.18
25	1.62	1.41	1.63	1.41
35	1.20	1.04	1.19	1.03
50	0.91	0.79	0.90	0.78
70	0.66	0.57	0.65	0.56
95	0.50	0.44	0.49	0.42
120	0.42	0.36	0.40	0.35
150	0.36	0.31	0.35	0.30
185	0.30	0.26	0.29	0.25
240	0.26	0.22	0.24	0.21
300	0.22	0.19	0.21	0.18

Table 6: Specific voltage drop at  $\cos\phi = 0.8$  for copper cables

S[mm <sup>2</sup> ]	$\cos\phi = 0.8$			
	single-core cable		two-core cable	three-core cable
	single-phase	three-phase	single-phase	three-phase
1.5	23.88	20.68	24.30	21.05
2.5	14.44	12.51	14.66	12.69
4	9.08	7.87	9.21	7.98
6	6.10	5.28	6.16	5.34
10	3.73	3.23	3.74	3.23
16	2.39	2.07	2.39	2.07
25	1.55	1.34	1.55	1.34
35	1.15	0.99	1.14	0.99
50	0.88	0.76	0.87	0.75
70	0.64	0.55	0.62	0.54
95	0.49	0.43	0.48	0.41
120	0.41	0.36	0.39	0.34
150	0.36	0.31	0.34	0.29
185	0.31	0.26	0.29	0.25
240	0.26	0.22	0.24	0.21
300	0.23	0.20	0.21	0.19

## 2 Protection of feeders

Table 7: Specific voltage drop at  $\cos\phi=0.75$  for copper cables

S[mm <sup>2</sup> ]	$\cos\phi = 0.75$			
	single-core cable		two-core cable	three-core cable
	single-phase	three-phase	single-phase	three-phase
1.5	22.42	19.42	22.81	19.75
2.5	13.57	11.75	13.76	11.92
4	8.54	7.40	8.65	7.49
6	5.74	4.97	5.80	5.02
10	3.52	3.05	3.52	3.05
16	2.26	1.96	2.25	1.95
25	1.47	1.28	1.47	1.27
35	1.10	0.95	1.08	0.94
50	0.84	0.73	0.83	0.72
70	0.62	0.54	0.60	0.52
95	0.48	0.42	0.46	0.40
120	0.41	0.35	0.38	0.33
150	0.35	0.31	0.33	0.29
185	0.30	0.26	0.29	0.25
240	0.26	0.23	0.24	0.21
300	0.23	0.20	0.22	0.19

Table 8: Specific voltage drop at  $\cos\phi = 1$  for aluminium cables

S[mm <sup>2</sup> ]	$\cos\phi = 1$			
	single-core cable		two-core cable	three-core cable
	single-phase	three-phase	single-phase	three-phase
1.5	48.77	42.23	49.76	43.09
2.5	29.36	25.43	29.92	25.91
4	18.35	15.89	18.72	16.21
6	12.22	10.59	12.46	10.79
10	7.38	6.39	7.48	6.48
16	4.65	4.02	4.71	4.08
25	2.93	2.54	2.99	2.59
35	2.11	1.83	2.15	1.87
50	1.56	1.35	1.59	1.38
70	1.08	0.94	1.10	0.95
95	0.78	0.67	0.79	0.69
120	0.62	0.54	0.63	0.55
150	0.50	0.44	0.52	0.45
185	0.41	0.35	0.41	0.36
240	0.31	0.27	0.32	0.28
300	0.25	0.22	0.26	0.22

## 2 Protection of feeders

Table 9: Specific voltage drop at  $\cos\phi = 0.9$  for aluminium cables

S[mm <sup>2</sup> ]	$\cos\phi = 0.9$			
	single-core cable		two-core cable	three-core cable
	single-phase	three-phase	single-phase	three-phase
1.5	44.04	38.14	44.88	38.87
2.5	26.56	23.00	27.02	23.40
4	16.64	14.41	16.93	14.66
6	11.12	9.63	11.29	9.78
10	6.75	5.84	6.81	5.89
16	4.28	3.71	4.31	3.73
25	2.73	2.36	2.76	2.39
35	1.99	1.72	2.01	1.74
50	1.49	1.29	1.50	1.30
70	1.06	0.92	1.06	0.91
95	0.78	0.68	0.78	0.68
120	0.64	0.55	0.63	0.55
150	0.53	0.46	0.53	0.46
185	0.44	0.38	0.44	0.38
240	0.36	0.31	0.35	0.30
300	0.30	0.26	0.30	0.26

Table 10: Specific voltage drop at  $\cos\phi = 0.85$  for aluminium cables

S[mm <sup>2</sup> ]	$\cos\phi = 0.85$			
	single-core cable		two-core cable	three-core cable
	single-phase	three-phase	single-phase	three-phase
1.5	41.63	36.05	42.42	36.73
2.5	25.12	21.75	25.55	22.12
4	15.75	13.64	16.02	13.87
6	10.53	9.12	10.69	9.26
10	6.40	5.54	6.45	5.58
16	4.07	3.52	4.09	3.54
25	2.60	2.25	2.63	2.27
35	1.90	1.65	1.91	1.66
50	1.43	1.24	1.43	1.24
70	1.02	0.88	1.01	0.88
95	0.76	0.66	0.76	0.65
120	0.63	0.54	0.61	0.53
150	0.53	0.46	0.52	0.45
185	0.44	0.38	0.43	0.37
240	0.36	0.31	0.35	0.30
300	0.31	0.27	0.30	0.26

## 2 Protection of feeders

Table 11: Specific voltage drop at  $\cos\phi = 0.8$  for aluminium cables

S[mm <sup>2</sup> ]	$\cos\phi = 0.8$			
	single-core cable		two-core cable	three-core cable
	single-phase	three-phase	single-phase	three-phase
1.5	39.22	33.96	39.95	34.59
2.5	23.67	20.50	24.07	20.84
4	14.85	12.86	15.09	13.07
6	9.94	8.61	10.08	8.73
10	6.05	5.24	6.09	5.27
16	3.85	3.34	3.87	3.35
25	2.47	2.14	2.49	2.16
35	1.81	1.57	1.82	1.57
50	1.37	1.18	1.37	1.18
70	0.98	0.85	0.97	0.84
95	0.74	0.64	0.73	0.63
120	0.61	0.53	0.59	0.51
150	0.51	0.45	0.50	0.44
185	0.43	0.38	0.42	0.36
240	0.36	0.31	0.34	0.30
300	0.31	0.27	0.30	0.26

Table 12: Specific voltage drop at  $\cos\phi = 0.75$  for aluminium cables

S[mm <sup>2</sup> ]	$\cos\phi = 0.75$			
	single-core cable		two-core cable	three-core cable
	single-phase	three-phase	single-phase	three-phase
1.5	36.80	31.87	37.47	32.45
2.5	22.23	19.25	22.58	19.56
4	13.95	12.08	14.17	12.27
6	9.35	8.09	9.47	8.20
10	5.69	4.93	5.72	4.96
16	3.63	3.15	3.64	3.15
25	2.34	2.02	2.35	2.03
35	1.72	1.49	1.72	1.49
50	1.30	1.13	1.30	1.12
70	0.94	0.81	0.92	0.80
95	0.71	0.62	0.70	0.60
120	0.59	0.51	0.57	0.49
150	0.50	0.43	0.49	0.42
185	0.42	0.37	0.41	0.35
240	0.35	0.31	0.34	0.29
300	0.31	0.27	0.29	0.25

## 2 Protection of feeders

### Example 1

To calculate a voltage drop on a three-phase cable with the following specifications:

- rated voltage: 400 V;
- cable length: 25 m;
- cable formation: single-core copper cable, 3x50 mm<sup>2</sup>;
- load current  $I_b$ : 100 A;
- power factor  $\cos\phi$ : 0.9.

From Table 4, for a 50 mm<sup>2</sup> single-core cable it is possible to read that a  $\Delta U_x$  voltage drop corresponds to 0.81 V/(A·km). By multiplying this value by the length in km and by the current in A, it results:

$$\Delta U = \Delta U_x \cdot I_b \cdot L = 0.81 \cdot 100 \cdot 0.025 = 2.03 \text{ V}$$

which corresponds to this percentage value:

$$\Delta u\% = \frac{\Delta U}{U_r} \cdot 100 = \frac{2.03}{400} \cdot 100 = 0.51\%$$

### Example 2

To calculate a voltage drop on a three-phase cable with the following specifications:

- rated voltage: 690 V;
- cable length: 50 m;
- cable formation: multi-core copper cable, 2x(3x10) mm<sup>2</sup>;
- load current  $I_b$ : 50 A;
- power factor  $\cos\phi$ : 0.85.

From Table 5, for a multi-core 10 mm<sup>2</sup> cable it is possible to read that  $\Delta U_x$  voltage drop corresponds to 3.42 V/(A·km). By multiplying this value by the length in km and by the current in A, and by dividing it by the number of cables in parallel, it results:

$$\Delta U = \Delta U_x \cdot I_b \cdot \frac{L}{2} = 3.42 \cdot 50 \cdot \frac{0.05}{2} = 4.28 \text{ V}$$

which corresponds to this percentage value:

$$\Delta u\% = \frac{\Delta U}{U_r} \cdot 100 = \frac{4.28}{690} \cdot 100 = 0.62\%$$

## 2 Protection of feeders

### Method for defining the cross section of the conductor according to voltage drop in the case of long cables

In the case of long cables, or if particular design specifications impose low limits for maximum voltage drops, the verification using as reference the cross section calculated on the basis of thermal considerations (calculation according to chapter 2.2.1 "Current carrying capacity and methods of installation") may have a negative result.

To define the correct cross section, the maximum  $\Delta U_{x\max}$  value calculated by using the formula:

$$\Delta U_{x\max} = \frac{\Delta u\% \cdot U_r}{100 \cdot I_b \cdot L} \quad (3)$$

is compared with the corresponding values on Tables 4÷12 by choosing the smallest cross section with a  $\Delta U_x$  value lower than  $\Delta U_{x\max}$ .

### Example:

Supply of a three-phase load with  $P_u = 35 \text{ kW}$  ( $U_r = 400 \text{ V}$ ,  $f_r = 50 \text{ Hz}$ ,  $\cos\phi = 0.9$ ) with a 140 m cable installed on a perforated tray, consisting of a multi-core copper cable with EPR insulation.

Maximum permitted voltage drop 2%.

Load current  $I_b$  is:

$$I_b = \frac{P_u}{\sqrt{3} \cdot U_r \cdot \cos\phi} = \frac{35000}{\sqrt{3} \cdot 400 \cdot 0.9} = 56 \text{ A}$$

The Table 8 of Chapter 2.2.1 shows  $S = 10 \text{ mm}^2$ .

From Table 4, for the multi-core 10 mm<sup>2</sup> cable it is possible to read that the voltage drop per A and per km is 3.60 V/(A·km). By multiplying this value by the length in km and by the current in A, it results:

$$\Delta U = 3.60 \cdot I_b \cdot L = 3.6 \cdot 56 \cdot 0.14 = 28.2 \text{ V}$$

which corresponds to this percentage value:

$$\Delta u\% = \frac{\Delta U}{U_r} \cdot 100 = \frac{28.2}{400} \cdot 100 = 7.05\%$$

This value is too high.

Formula (3) shows:

$$\Delta U_{x\max} = \frac{\Delta u\% \cdot U_r}{100 \cdot I_b \cdot L} = \frac{2\% \cdot 400}{100 \cdot 56 \cdot 0.14} = 1.02 \text{ V/(A} \cdot \text{km)}$$

## 2 Protection of feeders

From Table 4 a cross section of 50 mm<sup>2</sup> can be chosen.

For this cross section  $\Delta U_x = 0.81 < 1.02 \text{ V/(A}\cdot\text{km)}$ .

By using this value it results:

$$\Delta U = \Delta U_x \cdot I_b \cdot L = 0.81 \cdot 56 \cdot 0.14 = 6.35 \text{ V}$$

This corresponds to a percentage value of:

$$\Delta u\% = \frac{\Delta U}{U_r} \cdot 100 = \frac{6.35}{400} \cdot 100 = 1.6\%$$

### 2.2.3 Joule-effect losses

Joule-effect losses are due to the electrical resistance of the cable.

The lost energy is dissipated in heat and contributes to the heating of the conductor and of the environment.

A first estimate of three-phase losses is:

$$P_j = \frac{3 \cdot r \cdot I_b^2 \cdot L}{1000} \text{ [W]}$$

whereas single-phase losses are:

$$P_j = \frac{2 \cdot r \cdot I_b^2 \cdot L}{1000} \text{ [W]}$$

where:

- $I_b$  is the load current [A];
- $r$  is the phase resistance per unit of length of the cable at 80 °C [ $\Omega/\text{km}$ ] (see Table 1);
- $L$  is the cable length [m].

**Table 1: Resistance values [ $\Omega/\text{km}$ ] of single-core and multi-core cables in copper and aluminium at 80 °C**

S [mm <sup>2</sup> ]	Single-core cable		Two-core/three-core cable	
	Cu	Al	Cu	Al
1.5	14.8	24.384	15.1	24.878
2.5	8.91	14.680	9.08	14.960
4	5.57	9.177	5.68	9.358
6	3.71	6.112	3.78	6.228
10	2.24	3.691	2.27	3.740
16	1.41	2.323	1.43	2.356
25	0.889	1.465	0.907	1.494
35	0.641	1.056	0.654	1.077
50	0.473	0.779	0.483	0.796
70	0.328	0.540	0.334	0.550
95	0.236	0.389	0.241	0.397
120	0.188	0.310	0.191	0.315
150	0.153	0.252	0.157	0.259
185	0.123	0.203	0.125	0.206
240	0.0943	0.155	0.0966	0.159
300	0.0761	0.125	0.078	0.129

## 2 Protection of feeders

### 2.3 Protection against overload

The Standard IEC 60364-4-43 "Electrical installation of buildings - Protection against overcurrent" specifies coordination between conductors and overload protective devices (normally placed at the beginning of the conductor to be protected) so that it shall satisfy the two following conditions:

$$I_b \leq I_n \leq I_z \tag{1}$$

$$I_2 \leq 1.45 \cdot I_z \tag{2}$$

Where:

- $I_b$  is the current for which the circuit is dimensioned;
- $I_z$  is the continuous current carrying capacity of the cable;
- $I_n$  is the rated current of the protective device; for adjustable protective releases, the rated current  $I_n$  is the set current;
- $I_2$  is the current ensuring effective operation in the conventional time of the protective device.

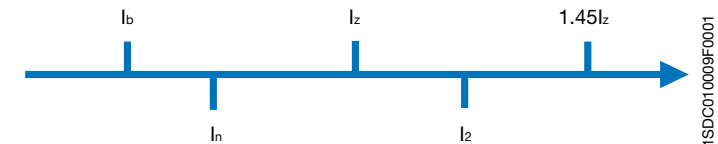

1SDC010009F0001

According to condition (1) to correctly choose the protective device, it is necessary to check that the circuit-breaker has a rated (or set) current that is:

- higher than the load current, to prevent unwanted tripping;
  - lower than the current carrying capacity of the cable, to prevent cable overload.
- The Standard allows an overload current that may be up to 45% greater than the current carrying capacity of the cable but only for a limited period (conventional trip time of the protective device).

The verification of condition (2) is not necessary in the case of circuit-breakers because the protective device is automatically tripped if:

- $I_2 = 1.3 \cdot I_n$  for circuit-breakers complying with IEC 60947-2 (circuit-breakers for industrial use);
- $I_2 = 1.45 \cdot I_n$  for circuit-breakers complying with IEC 60898 (circuit-breakers for household and similar installations).

Therefore, for circuit-breakers, if  $I_n \leq I_z$ , the formula  $I_2 \leq 1.45 \cdot I_z$  will also be verified.

When the protective device is a fuse, it is also essential to check formula (2) because IEC 60269-2-1 on "Low-voltage fuses" states that a  $1.6 \cdot I_n$  current must automatically melt the fuse. In this case, formula (2) becomes  $1.6 \cdot I_n \leq 1.45 \cdot I_z$  or  $I_n \leq 0.9 \cdot I_z$ .

## 2 Protection of feeders

**To summarize:** to carry out by a fuse protection against overload, the following must be achieved:

$$I_b \leq I_n \leq 0.9 \cdot I_z$$

and this means that the cable is not fully exploited.

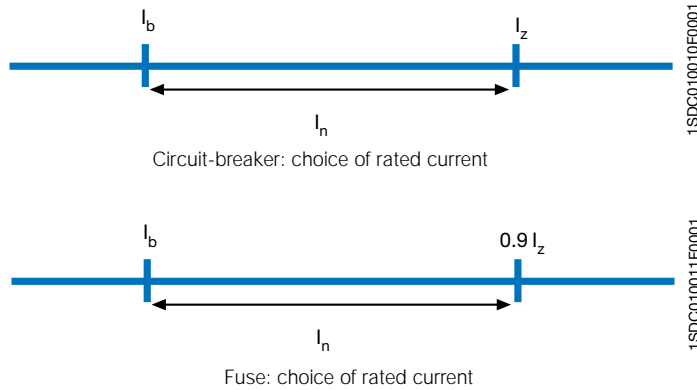

Where the use of a single conductor per phase is not feasible, and the currents in the parallel conductors are unequal, the design current and requirements for overload protection for each conductor shall be considered individually.

### Examples

#### Example 1

*Load specifications*

$P_r = 70 \text{ kW}$ ;  $U_r = 400 \text{ V}$ ;  $\cos\phi = 0.9$ ; three-phase load so  $I_b = 112 \text{ A}$

*Cable specifications*

$I_z = 134 \text{ A}$

*Protective device specifications*

T1B160 TMD  $I_n125$ ; set current  $I1 = 125 \text{ A}$

## 2 Protection of feeders

### Example 2

*Load specifications*

$P_r = 80 \text{ kW}$ ;  $\cos\phi = 0.9$ ;  $U_r = 400 \text{ V}$ ; three-phase load so  $I_b = 128 \text{ A}$

*Cable specifications*

$I_z = 171 \text{ A}$

*Protective device specifications*

T2N160 PR221DS-LS  $I_n160$ ; set current  $I1 = 0.88 \times I_n = 140.8 \text{ A}$

### Example 3

*Load specifications*

$P_r = 100 \text{ kW}$ ;  $\cos\phi = 0.9$ ;  $U_r = 400 \text{ V}$ ; three-phase load so  $I_b = 160 \text{ A}$

*Cable specifications*

$I_z = 190 \text{ A}$

*Protective device specifications*

T3N250 TMD  $I_n200$ ; set current  $I1 = 0.9 \times I_n = 180 \text{ A}$

### Example 4

*Load specifications*

$P_r = 25 \text{ kW}$ ;  $\cos\phi = 0.9$ ;  $U_r = 230 \text{ V}$ ; single-phase load so  $I_b = 121 \text{ A}$

*Cable specifications*

$I_z = 134 \text{ A}$

*Protective device specifications*

T1B160 1P TMF  $I_n125$

## 2 Protection of feeders

### 2.4 Protection against short-circuit

A cable is protected against short-circuit if the specific let-through energy of the protective device ( $I^2t$ ) is lower or equal to the withstood energy of the cable ( $k^2S^2$ ):

$$I^2t \leq k^2S^2 \quad (1)$$

where

- $I^2t$  is the specific let-through energy of the protective device which can be read on the curves supplied by the manufacturer (see *Electrical installation handbook*, Vol. 1, Chapter 3.4 "Specific let-through energy curves") or from a direct calculation in the case of devices that are not limiting and delaying;
- $S$  is the cable cross section [mm<sup>2</sup>]; in the case of conductors in parallel it is the cross section of the single conductor;
- $k$  is a factor that depends on the cable insulating and conducting material. The values of the most common installations are shown in Table 1; for a more detailed calculation, see Annex D.

Table 1: Values of k for phase conductor

	Conductor insulation					
	PVC ≤300 mm <sup>2</sup>	PVC >300 mm <sup>2</sup>	EPR XLPE	Rubber 60 °C	Mineral	
					PVC	Bare
Initial temperature °C	70	70	90	60	70	105
Final temperature °C	160	140	250	200	160	250
Material of conductor:						
Copper	115	103	143	141	115	135/115 <sup>a</sup>
Aluminium	76	68	94	93	-	-
tin-soldered joints in copper conductors	115	-	-	-	-	-
<sup>a</sup> This value shall be used for bare cables exposed to touch.						
NOTE 1 Other values of k are under consideration for: - small conductors (particularly for cross section less than 10 mm <sup>2</sup> ); - duration of short-circuit exceeding 5 s; - other types of joints in conductors; - bare conductors.						
NOTE 2 The nominal current of the short-circuit protective device may be greater than the current carrying capacity of the cable.						
NOTE 3 The above factors are based on IEC 60724.						

1SDC010010F0201

## 2 Protection of feeders

Table 2 shows the maximum withstood energy for cables according to the cross section, the conductor material and the type of insulation, which are calculated by using the parameters of Table 1.

Table 2: Maximum withstood energy for cables  $k^2 S^2$  [(kA)<sup>2</sup> s]

		Cross section [mm <sup>2</sup> ]								
Cable	k	1.5	2.5	4	6	10	16	25	35	
PVC	Cu 115	2.98·10 <sup>-2</sup>	8.27·10 <sup>-2</sup>	2.12·10 <sup>-1</sup>	4.76·10 <sup>-1</sup>	1.32	3.39	8.27	1.62·10 <sup>1</sup>	
	Al 76	1.30·10 <sup>-2</sup>	3.61·10 <sup>-2</sup>	9.24·10 <sup>-2</sup>	2.08·10 <sup>-1</sup>	5.78·10 <sup>-1</sup>	1.48	3.61	7.08	
EPR/XLPE	Cu 143	4.60·10 <sup>-2</sup>	1.28·10 <sup>-1</sup>	3.27·10 <sup>-1</sup>	7.36·10 <sup>-1</sup>	2.04	5.23	1.28·10 <sup>1</sup>	2.51·10 <sup>1</sup>	
	Al 94	1.99·10 <sup>-2</sup>	5.52·10 <sup>-2</sup>	1.41·10 <sup>-1</sup>	3.18·10 <sup>-1</sup>	8.84·10 <sup>-1</sup>	2.26	5.52	1.08·10 <sup>1</sup>	
Rubber	Cu 141	4.47·10 <sup>-2</sup>	1.24·10 <sup>-1</sup>	3.18·10 <sup>-1</sup>	7.16·10 <sup>-1</sup>	1.99	5.09	1.24·10 <sup>1</sup>	2.44·10 <sup>1</sup>	
	Al 93	1.95·10 <sup>-2</sup>	5.41·10 <sup>-2</sup>	1.38·10 <sup>-1</sup>	3.11·10 <sup>-1</sup>	8.65·10 <sup>-1</sup>	2.21	5.41	1.06·10 <sup>1</sup>	

		Cross section [mm <sup>2</sup> ]								
Cable	k	50	70	95	120	150	185	240	300	
PVC	Cu 115	3.31·10 <sup>1</sup>	6.48·10 <sup>1</sup>	1.19·10 <sup>2</sup>	1.90·10 <sup>2</sup>	2.98·10 <sup>2</sup>	4.53·10 <sup>2</sup>	7.62·10 <sup>2</sup>	1.19·10 <sup>3</sup>	
	Al 76	1.44·10 <sup>1</sup>	2.83·10 <sup>1</sup>	5.21·10 <sup>1</sup>	8.32·10 <sup>1</sup>	1.30·10 <sup>2</sup>	1.98·10 <sup>2</sup>	3.33·10 <sup>2</sup>	5.20·10 <sup>2</sup>	
EPR/XLPE	Cu 143	5.11·10 <sup>1</sup>	1.00·10 <sup>2</sup>	1.85·10 <sup>2</sup>	2.94·10 <sup>2</sup>	4.60·10 <sup>2</sup>	7.00·10 <sup>2</sup>	1.18·10 <sup>3</sup>	1.84·10 <sup>3</sup>	
	Al 94	2.21·10 <sup>1</sup>	4.33·10 <sup>1</sup>	7.97·10 <sup>1</sup>	1.27·10 <sup>2</sup>	1.99·10 <sup>2</sup>	3.02·10 <sup>2</sup>	5.09·10 <sup>2</sup>	7.95·10 <sup>2</sup>	
G2	Cu 141	4.97·10 <sup>1</sup>	9.74·10 <sup>1</sup>	1.79·10 <sup>2</sup>	2.86·10 <sup>2</sup>	4.47·10 <sup>2</sup>	6.80·10 <sup>2</sup>	1.15·10 <sup>3</sup>	1.79·10 <sup>3</sup>	
	Al 93	2.16·10 <sup>1</sup>	4.24·10 <sup>1</sup>	7.81·10 <sup>1</sup>	1.25·10 <sup>2</sup>	1.95·10 <sup>2</sup>	2.96·10 <sup>2</sup>	4.98·10 <sup>2</sup>	7.78·10 <sup>2</sup>	

1SDC010002F0901

The formula (1) must be verified along the whole length of the cable. Due to the shape of the specific let-through energy curve of a circuit breaker, it is generally sufficient to verify formula (1) only for the maximum and minimum short-circuit current that may affect the cable. The maximum value is normally the value of the three-phase short-circuit current at the beginning of the line, while the minimum value is the value of the phase to neutral short-circuit current (phase to phase if the neutral conductor is not distributed) or phase to earth at the end of the cable.



## 2 Protection of feeders

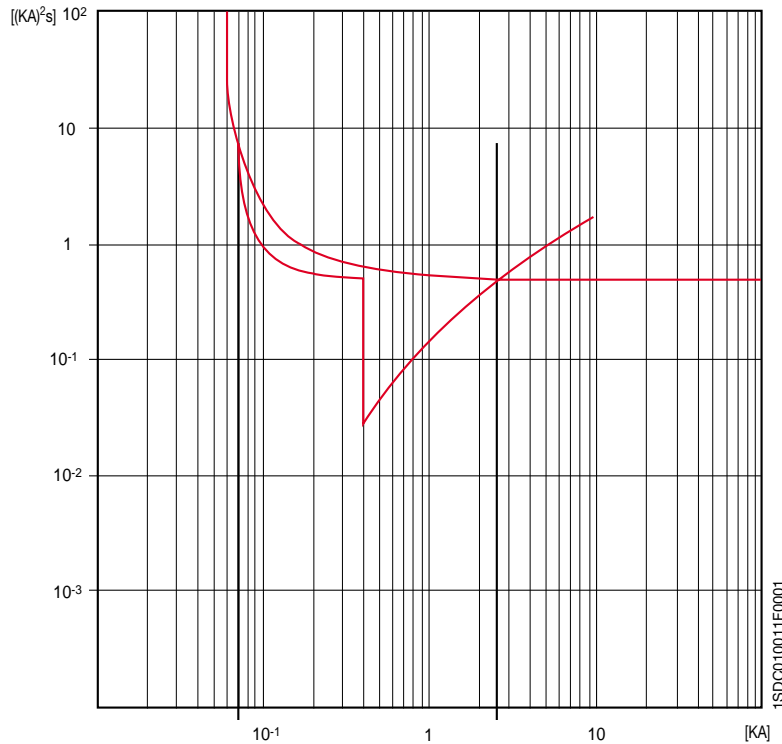

This verification can be simplified by comparing only the let-through energy value of the circuit-breaker at the maximum short-circuit current with the withstood energy of the cable and by ensuring that the circuit breaker trips instantaneously at the minimum short-circuit current: the threshold of the short-circuit protection (taking into consideration also the tolerances) shall therefore be lower than the minimum short-circuit current at the end of the conductor.

## 2 Protection of feeders

### Calculation of short-circuit current at end of the conductor

Minimum short-circuit current can be calculated by the following approximate formulas:

$$I_{kmin} = \frac{0.8 \cdot U_r \cdot k_{sec} \cdot k_{par}}{1.5 \cdot \rho \cdot \frac{2L}{S}} \quad \text{with non-distributed neutral conductor} \quad (2.1)$$

$$I_{kmin} = \frac{0.8 \cdot U_0 \cdot k_{sec} \cdot k_{par}}{1.5 \cdot \rho \cdot (1+m) \cdot \frac{L}{S}} \quad \text{with distributed neutral conductor} \quad (2.2)$$

where:

- $I_{kmin}$  is the minimum value of the prospective short-circuit current [kA];
- $U_r$  is the supply voltage [V];
- $U_0$  is the phase to earth supply voltage [V];
- $\rho$  is the resistivity at 20 °C of the material of the conductors in  $\Omega\text{mm}^2/\text{m}$  and is:
  - 0.018 for copper;
  - 0.027 for aluminium;
- $L$  is the length of the protected conductor [m];
- $S$  is the cross section of the conductor [mm<sup>2</sup>];
- $k_{sec}$  is the correction factor which takes into account the reactance of the cables with cross section larger than 95 mm<sup>2</sup>:

$S[\text{mm}^2]$	120	150	185	240	300
$k_{sec}$	0.9	0.85	0.80	0.75	0.72

- $k_{par}$  is the correcting coefficient for conductors in parallel:

number of parallel conductors	2	3	4	5
$k_{par}^*$	2	2.7	3	3.2

\* $k_{par} = 4(n-1)/n$  where:  $n$  = number of conductors in parallel per phase

- $m$  is the ratio between the resistances of the neutral conductor and the phase conductor (if they are made of the same material  $m$  is the ratio between the cross section of the phase conductor and the cross section of the neutral conductor).

After calculating the minimum short-circuit current, verify that

$$I_{kmin} > 1.2 \cdot I_3 \quad (3)$$

where:

- $I_3$  is the current that trips the magnetic protection of the circuit-breaker;
- 1.2 is the tolerance at the trip threshold.

## 2 Protection of feeders

### Example

Choice of CB1

System data:

Rated voltage 400 V

$I_k = 30 \text{ kA}$

Cable data:

Insulated copper conductor in PVC

Length = 150 m

$S = 50 \text{ mm}^2$

$I_z = 134 \text{ A}$

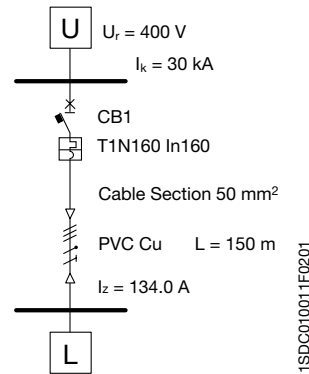

Protection against short-circuit at the beginning of the conductor

T1N160 In160 (breaking capacity 36 kA@400 V)

$I^2t (@30 \text{ kA}) = 7.5 \cdot 10^{-1} \text{ (kA)}^2\text{s}$  (for the curves of specific let-through energy, see Volume 1, Chapter 3.4)

$k^2S^2 = 1152 \cdot 50^2 = 3.31 \cdot 10^7 \text{ (kA)}^2\text{s}$

The cable is therefore protected against short-circuit at the beginning of the conductor.

Protection against short-circuit at end of the conductor

The minimum short-circuit current at end of the conductor ( $k_{sec}=1$  and  $k_{par}=1$ ) is:

$$I_{kmin} = \frac{0.8 \cdot U \cdot k_{sec} \cdot k_{par}}{1.5 \cdot \rho \cdot \frac{2L}{S}} = 1.98 \text{ kA}$$

The magnetic threshold of the circuit breaker T1N160 In160 is set at 1600 A. If tolerance is 20%, the circuit breaker shall definitely trip if the values exceed 1920 A; the cable is therefore fully protected against short-circuit.

### Maximum protected length

The formula (3), when solved for the length, enables the maximum length protected by the protective device to be obtained for a precise instantaneous trip threshold. In Table 3, the maximum protected length can be identified for a given cross section of the cable and for the setting threshold of the instantaneous protection of the circuit breaker against short-circuit:

- three-phase system, 400 V rated voltage;
- non-distributed neutral;
- copper conductor with resistivity equal to  $0.018 \Omega\text{mm}^2/\text{m}$ .

The values on the table below take into account the 20% tolerance coefficient for the magnetic trip value, the increase in cable resistivity due to heating caused by the short-circuit current and the reduction of voltage due to the fault.

The correction factors shown after the table must be applied if the system conditions are different from the reference conditions.

## 2 Protection of feeders

Table 3: Maximum protected length

$I_b$ [A]	section [mm <sup>2</sup> ]															
	1.5	2.5	4	6	10	16	25	35	50	70	95	120	150	185	240	300
20	370	617														
30	246	412	658													
40	185	309	494	741												
50	148	247	395	593												
60	123	206	329	494												
70	105	176	282	423	705											
80	92	154	246	370	617											
90	82	137	219	329	549											
100	74	123	197	296	494	790										
120	61	102	164	246	412	658										
140	52	88	141	211	353	564										
150	49	82	131	197	329	527										
160	46	77	123	185	309	494	772									
180	41	68	109	164	274	439	686									
200	37	61	98	148	247	395	617									
220	33	56	89	134	224	359	561	786								
250	29	49	79	118	198	316	494	691								
280	26	44	70	105	176	282	441	617								
300	24	41	65	98	165	263	412	576								
320	23	38	61	92	154	247	386	540	772							
350	21	35	56	84	141	226	353	494	705							
380	19	32	52	78	130	208	325	455	650							
400	18	30	49	74	123	198	309	432	617							
420	17	29	47	70	118	188	294	412	588							
450	16	27	43	65	110	176	274	384	549	768						
480	15	25	41	61	103	165	257	360	514	720						
500	14	24	39	59	99	158	247	346	494	691						
520	14	23	38	57	95	152	237	332	475	665						
550	13	22	35	53	90	144	224	314	449	629						
580	12	21	34	51	85	136	213	298	426	596	809					
600	12	20	32	49	82	132	206	288	412	576	782					
620	11	19	31	47	80	127	199	279	398	558	757					
650	11	19	30	45	76	122	190	266	380	532	722					
680	10	18	29	43	73	116	182	254	363	508	690					
700	10	17	28	42	71	113	176	247	353	494	670	847				
750		16	26	39	66	105	165	230	329	461	626	790	840			
800		15	24	37	62	99	154	216	309	432	586	667	787			
850		14	23	34	58	93	145	203	290	407	552	627	741			
900		13	21	32	55	88	137	192	274	384	521	593	700			
950		13	20	31	52	83	130	182	260	364	494	561	663			
1000		12	19	29	49	79	123	173	247	346	469	533	630	731		
1250			15	23	40	63	99	138	198	277	375	427	504	585	711	
1500			13	19	33	53	82	115	165	230	313	356	420	487	593	
1600			12	18	31	49	77	108	154	216	293	333	394	457	556	667
2000				14	25	40	62	86	123	173	235	267	315	365	444	533
2500				11	20	32	49	69	99	138	188	213	252	292	356	427
3000					16	26	41	58	82	115	156	178	210	244	296	356
3200					15	25	39	54	77	108	147	167	197	228	278	333
4000					12	20	31	43	62	86	117	133	157	183	222	267
5000					10	16	25	35	49	69	94	107	126	146	178	213
6300						13	20	27	39	55	74	85	100	116	141	169
8000						10	15	22	31	43	59	67	79	91	111	133
9600							13	18	26	36	49	56	66	76	93	111
10000							12	17	25	35	47	53	63	73	89	107
12000							10	14	21	29	39	44	52	61	74	89
15000								12	16	23	31	36	42	49	59	71
20000								12	17	23	27	31	37	44	53	
24000									10	14	20	22	26	30	37	44
30000										12	16	20	25	30	40	49

## 2 Protection of feeders

Correction factor for voltage other than 400 V:  $k_v$

Multiply the length value obtained from the table by the correction factor  $k_v$ :

$U_r$ [V] (three-phase value)	$k_v$
230 <sup>(*)</sup>	0.58
400	1
440	1.1
500	1.25
690	1.73

<sup>(\*)</sup> 230 V single-phase is the equivalent of a three-phase 400 V system with distributed neutral and with the cross section of the phase conductor the same as the cross section area of the neutral conductor, so that  $k_v$  is 0.58.

Correction factor for distributed neutral:  $k_d$

Multiply the length value obtained from the table by the correction factor  $k_d$ :

$$k_d = \frac{2}{\sqrt{3}} \cdot \frac{1}{1 + \frac{S}{S_N}}$$

where

- $S$  is the phase cross section [mm<sup>2</sup>];
- $S_N$  is the neutral cross section [mm<sup>2</sup>].

In particular:

$$\text{if } S = S_N \rightarrow k_d \text{ is } 0.58;$$

$$\text{if } S = 2 \cdot S_N \rightarrow k_d \text{ is } 0.39.$$

Correction factor for aluminium conductors:  $k_r$

If the cable is in aluminium, multiply the length value obtained from the table above by the correction factor  $k_r = 0.67$ .

## 2 Protection of feeders

To summarize:

On the table, for the cross section and magnetic trip threshold it is possible to read a maximum protected value  $L_0$ . This length shall then be multiplied, if necessary, by the correction factors in order to obtain a value that is compatible with the installation operating conditions:

$$L = L_0 k_v k_d k_r$$

### Example 1

Neutral not distributed

Rated voltage = 400 V

Protective device: T2N160 TMD In100

Magnetic threshold:  $I_3 = 1000$  A

Phase cross section = Neutral cross section = 70 mm<sup>2</sup>

The table shows that at  $I_3 = 1000$  A, the 70 mm<sup>2</sup> cable is protected up to 346 m.

### Example 2

Neutral distributed

Rated voltage = 400 V

Protective device: T3S250 TMD In200

Magnetic threshold:  $I_3 = 2000$  A

Phase cross section = 300 mm<sup>2</sup>

Neutral cross section = 150 mm<sup>2</sup>

For  $I_3 = 2000$  A and  $S = 300$  mm<sup>2</sup>, a protected length equivalent of  $L_0 = 533$  m is obtained.

By applying the correction factor  $k_d$  required when the neutral is distributed:

$$k_d = \frac{2}{\sqrt{3}} \cdot \frac{1}{1 + \frac{S}{S_N}} = \frac{2}{\sqrt{3}} \cdot \frac{1}{1 + \frac{300}{150}} = 0.39$$

$$L = L_0 \cdot 0.39 = 533 \cdot 0.39 = 207.9 \text{ m}$$

This is the maximum protected length with neutral distributed.

## 2 Protection of feeders

### 2.5 Neutral and protective conductors

#### Neutral conductor

The neutral conductor is a conductor that is connected to the system neutral point (which generally but not necessarily coincides with the star centre of the secondary windings of the transformer or the windings of the generator); it is able to contribute to the transmission of electric power, thereby making available a voltage that is different from the phase to phase voltage. In certain cases and under specific conditions, the functions of neutral conductor and protective conductor can be combined in a single conductor (PEN).

#### Protection and disconnection of the neutral conductor

If fault conditions arise, a voltage to earth may occur on the neutral conductor. This may be caused by a phase to neutral short-circuit and by the disconnection of the neutral conductor due to accidental breaking or to tripping of single-pole devices (fuses or single-pole circuit breakers).  
 If the neutral conductor only is disconnected in a four-conductor circuit, the supply voltage to the single-phase loads may be altered so that they are supplied by a voltage different from the  $U_0$  phase to neutral voltage (as shown in Fig. 1). Therefore, all the necessary measures to prevent this type of fault shall be taken, e.g. by not protecting the neutral conductor with single-pole devices.

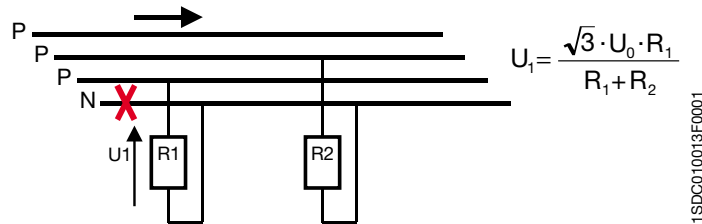

Figure 1: Disconnection of the neutral conductor

Moreover, in TN-C systems, voltage to earth arising on the neutral conductor constitutes a hazard for people; in fact, since this conductor is also a protective conductor, this voltage reaches the connected exposed conductive parts. For TN-C systems, the Standards specify minimum cross sections (see next clause) for the neutral conductor in order to prevent accidental breaking and they forbid the use of any device (single-pole or multi-pole) that could disconnect the PEN. The need for protection on the neutral conductor and the possibility of disconnecting the circuit depend on the distribution system:

1SDC010013F0001

## 2 Protection of feeders

TT or TN systems:

- if the cross section of the neutral conductor is the same or larger than the cross section of the phase conductor, there is neither the need to detect overcurrents on the neutral conductor nor to use a breaking device (neutral conductor is not protected or disconnected); this requirement applies only if there are no harmonics that may, at any instant, cause r.m.s. current values on the neutral conductor higher than the maximum current detected on the phase conductors;
- if the cross section of the neutral conductor is less than the cross section of the phase conductor, overcurrents on the neutral conductor must be detected so as to have the phase conductors, but not necessarily the neutral conductor, disconnected (neutral conductor protected but not disconnected): in this case the overcurrents on the neutral conductor do not need to be detected if the following conditions are simultaneously fulfilled:
  1. the neutral conductor is protected against short-circuit by the protective device of the phase conductors;
  2. the maximum current that can flow through the neutral conductor during normal service is lower than the neutral current carrying capacity.

In TN-S systems, the neutral need not be disconnected if the supply conditions are such that the neutral conductor can be considered to be reliable at earth potential. As already mentioned, in TN-C systems, the neutral conductor is also a protective conductor and cannot therefore be disconnected. Furthermore, if the neutral conductor is disconnected, the exposed conductive parts of the single-phase equipment could take the system rated voltage to earth. In certain specific cases, the neutral conductor has to be disconnected to prevent currents circulating between parallel supply sources (see Figures 2 and 3).

Figure 2: Three-phase alternative power supply with a 4-pole switch

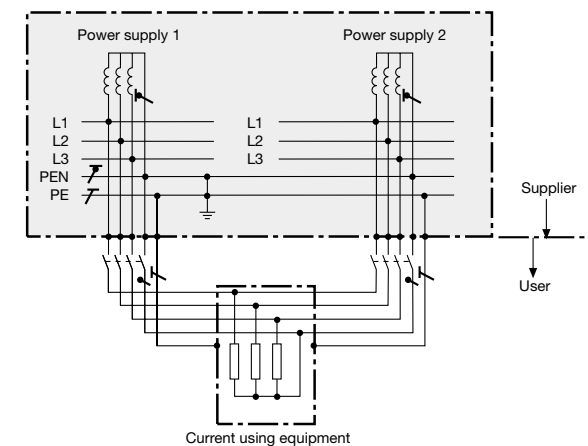

NOTE - This method prevents electromagnetic fields due to stray currents in the main supply system of an installation. The sum of the currents within one cable must be zero. This ensures that the neutral current will flow only in the neutral conductor of the respective switched on circuit. The 3rd harmonic (150 Hz) current of the line conductors will be added with the same phase angle to the neutral conductor current.

1SDC010012F0201

## 2 Protection of feeders

Figure 3: Three-phase alternative power supply with non-suitable 3-pole switch

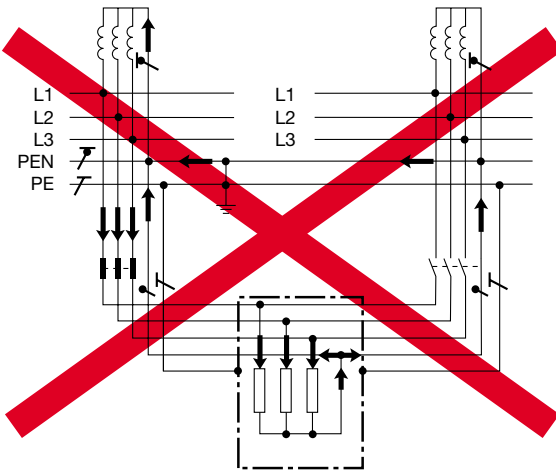

NOTE – A three-phase alternative power supply with a non-suitable 3-pole switch, due to unintentional circular stray currents generating electromagnetic fields.

### IT system:

The Standard advises against distributing the neutral conductor in IT systems. If the neutral conductor is distributed, the overcurrents must be detected on the neutral conductor of each circuit in order to disconnect all the live conductors on the corresponding circuit, including the neutral one (neutral conductor protected and disconnected).

Overcurrents do not need to be detected on the neutral conductor in any of the following cases:

- the neutral conductor is protected against short-circuit by a protective device fitted upstream;
- the circuit is protected by a residual current device with rated residual current lower than 0.15 times the current carrying capacity of the corresponding neutral conductor. This device must disconnect all the live conductors, the neutral conductor included.

For all distribution systems, whenever necessary, connection and disconnection of the neutral conductor, shall ensure that:

- the neutral conductor is not disconnected before the phase conductor;
- the neutral conductor is connected at the same moment or before the phase conductor.

1SDC010014F0001

## 2 Protection of feeders

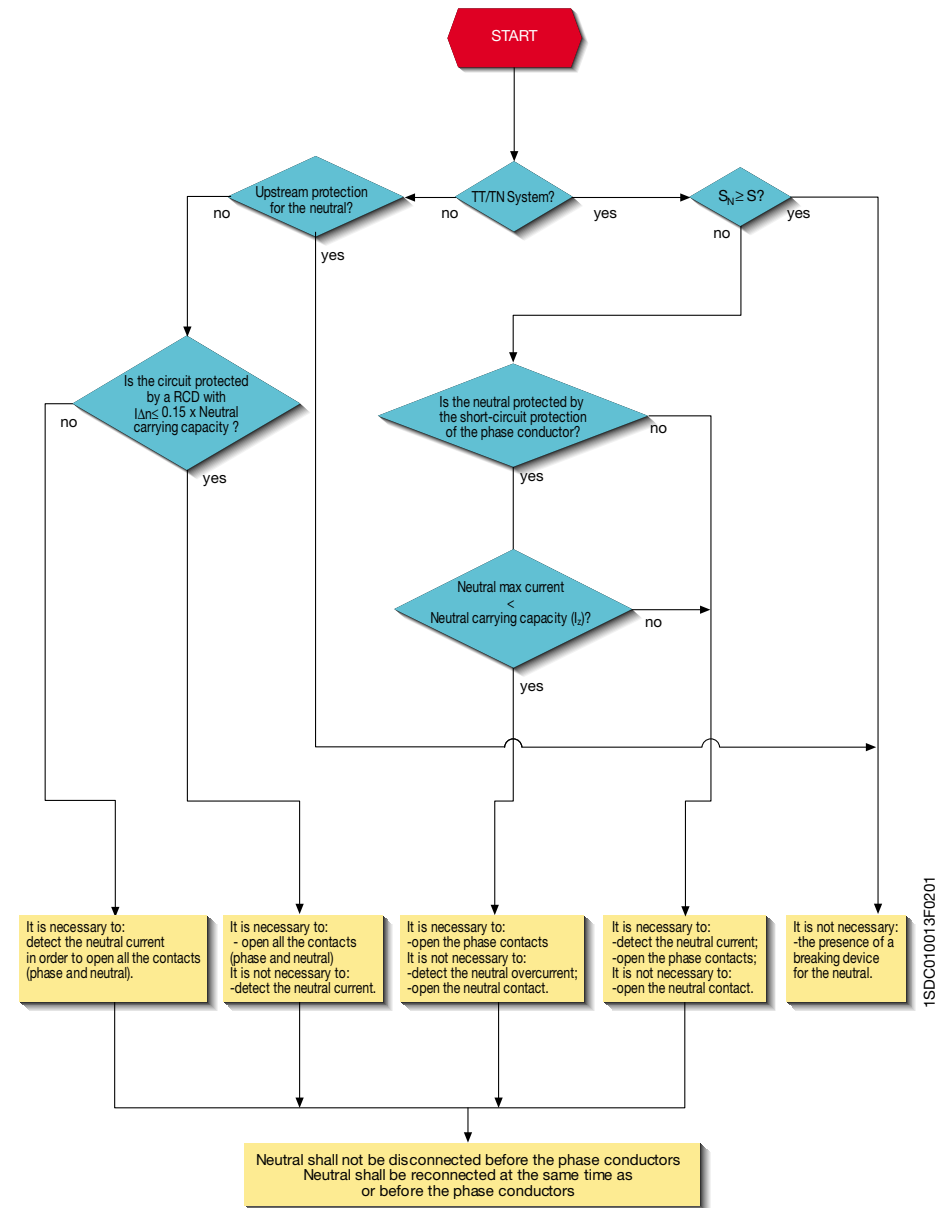

1SDC010013F0201

## 2 Protection of feeders

### Determination of the minimum cross section of the neutral conductor

The neutral conductor, if any, shall have the same cross section as the line conductor:

- in single-phase, two-wire circuits whatever the section;
- in polyphase and single-phase three-wire circuits, when the size of the line conductors is less than or equal to 16 mm<sup>2</sup> in copper, or 25 mm<sup>2</sup> in aluminium.<sup>1</sup>

The cross section of the neutral conductor can be less than the cross section of the phase conductor when the cross section of the phase conductor is greater than 16 mm<sup>2</sup> with a copper cable, or 25 mm<sup>2</sup> with an aluminium cable, if both the following conditions are met:

- the cross section of the neutral conductor is at least 16 mm<sup>2</sup> for copper conductors and 25 mm<sup>2</sup> for aluminium conductors;
- there is no high harmonic distortion of the load current. If there is high harmonic distortion (the harmonic content is greater than 10%), as for example in equipment with discharge lamps, the cross section of the neutral conductor cannot be less than the cross section of the phase conductors.

**Table 1: Minimum cross sections of the neutral conductor**

	Phase cross section S [mm <sup>2</sup> ]	Min. neutral cross section S <sub>N</sub> [mm <sup>2</sup> ]
<b>Single-phase/two-phase circuits</b>		
Cu/Al	Any	S <sup>*</sup>
<b>Three-phase circuits</b>		
Cu	S ≤ 16	S <sup>*</sup>
	S > 16	16
<b>Three-phase circuits</b>		
Al	S ≤ 25	S <sup>*</sup>
	S > 25	25

<sup>\*</sup>For TN-C systems, the Standards specify a minimum cross section of 10 mm<sup>2</sup> for copper and 16 mm<sup>2</sup> for aluminium conductors

<sup>1</sup> The cross section of phase conductors shall be dimensioned in compliance with the instructions of the Chapter 2.2.1 "Current carrying capacity and methods of installation"

## 2 Protection of feeders

### Protective conductor

#### Determination of the minimum cross sections

The minimum cross section of the protective conductor can be determined by using the following table:

**Table 2: Cross section of the protective conductor**

Cross section of line conductor S [mm <sup>2</sup> ]	Minimum cross section of the corresponding protective conductor [mm <sup>2</sup> ]	
	If the protective conductor is of the same material as the line conductor	If the protective conductor is not of the same material as the line conductor
S ≤ 16	S	$\frac{k_1}{k_2} \cdot S$
16 < S ≤ 35	16 <sup>*</sup>	$\frac{k_1}{k_2} \cdot 16$
S > 35	$\frac{S^*}{2}$	$\frac{k_1}{k_2} \cdot \frac{S}{2}$
Where k <sub>1</sub> is the value of k for the line conductor, selected from Table 1 Chapter 2.4 according to the materials of the conductor and insulation; k <sub>2</sub> is the value of k for the protective conductor. <sup>*</sup> For a PEN conductor, the reduction of the cross section is permitted only in accordance with the rules for sizing of the neutral conductor.		

1SDC010014F0201

For a more accurate calculation and if the protective conductor is subjected to adiabatic heating from an initial known temperature to a final specified temperature (applicable for fault extinction time no longer than 5s), the minimum cross section of the protective conductor S<sub>PE</sub> can be obtained by using the following formula:

$$S_{PE} = \frac{\sqrt{I^2 t}}{k} \quad (1)$$

where:

- S<sub>PE</sub> is the cross section of the protective conductor [mm<sup>2</sup>];
- I is the r.m.s. current flowing through the protective conductor in the event of a fault with low impedance [A];
- t is the trip time of the protective device [s];

## 2 Protection of feeders

- $k$  is a constant which depends on the material of the protective conductor, on the type of insulation and on initial and final temperature. The most common values can be taken from Tables 3 and 4.

**Table 3: Values of  $k$  for insulated protective conductors not incorporated in cables and not bunched with other cables**

Conductor insulation	Temperature °C <sup>b</sup>		Material of conductor		
	Initial	Final	Copper	Aluminium	Steel
			Values for $k$		
70 °C PVC	30	160/140 <sup>a</sup>	143/133 <sup>a</sup>	95/88 <sup>a</sup>	52/49 <sup>a</sup>
90 °C PVC	30	143/133 <sup>a</sup>	143/133 <sup>a</sup>	95/88 <sup>a</sup>	52/49 <sup>a</sup>
90 °C thermosetting	30	250	176	116	64
60 °C rubber	30	200	159	105	58
85 °C rubber	30	220	168	110	60
Silicon rubber	30	350	201	133	73

<sup>a</sup> The lower value applies to PVC insulated conductors of cross section greater than 300 mm<sup>2</sup>.  
<sup>b</sup> Temperature limits for various types of insulation are given in IEC 60724.

1SDC010015F0201

**Table 4: Values of  $k$  for protective conductors as a core incorporated in a cable or bunched with other cables or insulated conductors**

Conductor insulation	Temperature °C <sup>b</sup>		Material of conductor		
	Initial	Final	Copper	Aluminium	Steel
			Values for $k$		
70 °C PVC	70	160/140 <sup>a</sup>	115/103 <sup>a</sup>	76/68 <sup>a</sup>	42/37 <sup>a</sup>
90 °C PVC	90	160/140 <sup>a</sup>	100/86 <sup>a</sup>	66/57 <sup>a</sup>	36/31 <sup>a</sup>
90 °C thermosetting	90	250	143	94	52
60 °C rubber	60	200	141	93	51
85 °C rubber	85	220	134	89	48
Silicon rubber	180	350	132	87	47

<sup>a</sup> The lower value applies to PVC insulated conductors of cross section greater than 300 mm<sup>2</sup>.  
<sup>b</sup> Temperature limits for various types of insulation are given in IEC 60724.

1SDC010015F0201

## 2 Protection of feeders

Further values of  $k$  can be taken from the Tables in Annex D, which provides the formula for accurate calculation of the value of  $k$ .

If Table 2 or formula (1) do not provide a standardized cross section, a larger standardized cross section shall be chosen.

Regardless of whether Table 2 or formula (1) are used, the cross section of the protective conductor, which is not part of the supply cable, shall be at least:

- 2.5 mm<sup>2</sup> Cu/16 mm<sup>2</sup> Al, if a mechanical protection is provided;
- 4 mm<sup>2</sup> Cu/16 mm<sup>2</sup> Al, if no mechanical protection is provided.

For current using equipment intended for permanent connection and with a protective conductor current exceeding 10 mA, reinforced protective conductors shall be designed as follows:

- either the protective conductor shall have a cross-sectional area of at least 10 mm<sup>2</sup> Cu or 16 mm<sup>2</sup> Al, through its total run;
- or a second protective conductor of at least the same cross-sectional area as required for protection against indirect contact shall be laid up to a point where the protective conductor has a cross-sectional area not less than 10 mm<sup>2</sup> Cu or 16 mm<sup>2</sup> Al. This requires that the appliance has a separate terminal for a second protective conductor.

When overcurrent protective devices are used for protection against electric shock, the protective conductor shall be incorporated in the same wiring system as the live conductors or be located in their immediate proximity.

## 2 Protection of feeders

### 2.6 Busbar trunking systems (BTSs)

In electrical installations for industrial environments, busbar trunking systems (BTSs) optimize the power distribution despite the inevitable modifications that are carried out (additions, displacements, replacement of loads) and to facilitate maintenance work and safety verifications.

They are mainly used for:

- supplying sources of light, safety and low power distribution;
- lighting lines (medium power);
- power supply and distribution (medium and large power);
- supplying moving equipment (bridge cranes).

Busbar trunking systems are subject to the following Standards:

- IEC 60439 – 1 “*Low-voltage switchgear and controlgear assemblies – Part 1: Type-tested and partially type-tested assemblies*”
- IEC 60439 – 2 “*Low-voltage switchgear and controlgear assemblies – Part 2: Particular requirements for busbar trunking systems (busways)*”.

BTSs consist of:

- *conductors/busbars*;
- *coupling*: electrical and mechanical connecting elements for different elements;
- *straight elements*: base elements of the line for carrying energy from the source to the loads;
- *routing elements*: flexible joints for the creation of curves or overcoming obstacles, horizontal and vertical angles, tee joints and cross elements to create any type of route;
- *pull boxes*: elements that enable lamps or operating machines to be supplied directly with integrated protection (fuses or circuit breakers);
- *suspensions/accessories*: hanging and fixing elements for BTS and for any support required for special loads (lighting components, etc).

### Dimensioning of a BTS

To dimension a BTS, the load current must be determined using the following data:

*Power supply*

- General type of load supply:
  - single-phase
  - three-phase.
- Type of BTS supply:
  - from one end;
  - from both ends;
  - central power supply.
- Rated voltage
- Short-circuit current at the supply point
- Ambient temperature.

*Loads*

- Number, distribution, power and  $\cos\phi$  and type of loads supplied by the same BTS

## 2 Protection of feeders

*BTS geometry*

- Type of installation:
  - flat;
  - edge-on;
  - vertical.
- Length.

NOTE: BTSs shall be placed at a distance from the walls and the ceilings in such a way as to enable visual inspection of connections during assembly and to facilitate insertion of the branch units.

If possible, it is preferable to install the BTS edge-on so as to improve mechanical resistance and reduce any possible deposit of powder and polluting substances that might affect the level of internal insulation.

### Load current calculation for three-phase system

Load current  $I_b$  for a three-phase system is calculated by the following formula:

$$I_b = \frac{P_t \cdot b}{\sqrt{3} \cdot U_r \cdot \cos \varphi_m} \quad [\text{A}] \quad (1)$$

where:

- $P_t$  is the sum of the active power of all the installed loads [W];
- $b$  is the supply factor, which is:
  - 1 if the BTS is supplied from one side only;
  - 1/2 if the BTS is supplied from the centre or from both ends simultaneously;
- $U_r$  is the operating voltage [V];
- $\cos\phi_m$  is the average power factor of the loads.

### Choice of BTS current carrying capacity

A BTS shall be chosen so that its current carrying capacity  $I_z$  complies with the following formula:

$$I_b \leq I_{z0} \cdot k_t = I_z \quad (2)$$

where:

- $I_{z0}$  is the current that the BTS can carry for an indefinite time at the reference temperature (40 °C);
- $I_b$  is the load current;
- $k_t$  is the correction factor for ambient temperature values other than the reference ambient temperature shown on Table 1.

**Table 1: Correction factor  $k_t$  for ambient temperature other than 40 °C**

Ambient Temperature [°C]	15	20	25	30	35	40	45	50
$k_t$	1.2	1.17	1.12	1.08	1.05	1	0.95	0.85



## 2 Protection of feeders

Note: the following tables show typical parameters of the BTS present on the market

Table 2: Current carrying capacity  $I_{20}$  of copper BTS

Size	Generic type	Number of conductors	$I_{20}$ [A]	$r_{ph}^*$ [mΩ/m]	$x_{ph}$ [mΩ/m]	$U_r$ [V]
25	25A 4 cond. Cu	4	25	6.964	1.144	400
25	25A 4 cond. Cu	4	25	6.876	1.400	400
25	25A 4+4 cond. Cu	4+4	25	6.876	1.400	400
40	40A 4 cond. Cu	4	40	3.556	0.792	400
40	40A 4 cond. Cu	4	40	3.516	1.580	400
40	40A 4+4 cond. Cu	4+4	40	3.516	1.580	400
40	40A 4 cond. Cu	4	40	2.173	0.290	400
63	63A 4 cond. Cu	4	63	1.648	0.637	400
100	100A 4 cond. Cu	4	100	0.790	0.366	400
160	160A 4 cond. Cu	4	160	0.574	0.247	400
160	160A 4 cond. Cu	4	160	0.335	0.314	500
160	160A 5 cond. Cu	5	160	0.335	0.314	500
250	250A 4 cond. Cu	4	250	0.285	0.205	1000
250	250A 5 cond. Cu	5	250	0.285	0.205	1000
250	250A 4 cond. Cu	4	250	0.194	0.205	500
250	250A 5 cond. Cu	5	250	0.194	0.205	500
315	315A 4 cond. Cu	4	315	0.216	0.188	1000
315	315A 5 cond. Cu	5	315	0.216	0.188	1000
350	350A 4 cond. Cu	4	350	0.142	0.188	500
350	350A 5 cond. Cu	5	350	0.142	0.188	500
400	400A 4 cond. Cu	4	400	0.115	0.129	1000
400	400A 5 cond. Cu	5	400	0.115	0.129	1000
500	500A 4 cond. Cu	4	500	0.092	0.129	500
500	500A 5 cond. Cu	5	500	0.092	0.129	500
630	630A 4 cond. Cu	4	630	0.073	0.122	1000
630	630A 5 cond. Cu	5	630	0.073	0.122	1000
700	700A 4 cond. Cu	4	700	0.077	0.122	500
700	700A 5 cond. Cu	5	700	0.077	0.122	500
700	700A 5 cond. Cu	5	700	0.077	0.122	500
700	700A 4 cond. Cu	4	700	0.077	0.122	500

## 2 Protection of feeders

Size	Generic type	Number of conductors	$I_{20}$ [A]	$r_{ph}^*$ [mΩ/m]	$x_{ph}$ [mΩ/m]	$U_r$ [V]
800	800A 4 cond. Cu	4	800	0.047	0.122	1000
800	800A 5 cond. Cu	5	800	0.047	0.122	1000
800	800A 4 cond. Cu	4	800	0.038	0.027	1000
800	800A 4 cond. Cu	4	800	0.072	0.122	500
800	800A 5 cond. Cu	5	800	0.072	0.122	500
1000	1000A 4 cond. Cu	4	1000	0.038	0.120	1000
1000	1000A 5 cond. Cu	5	1000	0.038	0.120	1000
1000	1000A 4 cond. Cu	4	1000	0.037	0.026	1000
1000	1000A 4 cond. Cu	4	1000	0.038	0.097	1000
1000	1000A 4 cond. Cu	4	1000	0.068	0.120	500
1000	1000A 5 cond. Cu	5	1000	0.068	0.120	500
1200	1200A 4 cond. Cu	4	1200	0.035	0.021	1000
1250	1250A 4 cond. Cu	4	1250	0.034	0.023	1000
1250	1250A 4 cond. Cu	4	1250	0.035	0.076	1000
1500	1500A 4 cond. Cu	4	1500	0.030	0.022	1000
1600	1600A 4 cond. Cu	4	1600	0.025	0.018	1000
1600	1600A 4 cond. Cu	4	1600	0.034	0.074	1000
2000	2000A 4 cond. Cu	4	2000	0.020	0.015	1000
2000	2000A 4 cond. Cu	4	2000	0.025	0.074	1000
2400	2400A 4 cond. Cu	4	2400	0.019	0.012	1000
2500	2500A 4 cond. Cu	4	2500	0.016	0.011	1000
2500	2500A 4 cond. Cu	4	2500	0.019	0.040	1000
3000	3000A 4 cond. Cu	4	3000	0.014	0.011	1000
3000	3000A 4 cond. Cu	4	3000	0.017	0.031	1000
3200	3200A 4 cond. Cu	4	3200	0.013	0.009	1000
3200	3200A 4 cond. Cu	4	3200	0.015	0.031	1000
4000	4000A 4 cond. Cu	4	4000	0.011	0.007	1000
4000	4000A 4 cond. Cu	4	4000	0.011	0.026	1000
5000	5000A 4 cond. Cu	4	5000	0.008	0.005	1000
5000	5000A 4 cond. Cu	4	5000	0.008	0.023	1000

\*phase resistance at  $I_{20}$

## 2 Protection of feeders

Table 3: Current carrying capacity  $I_{z0}$  of aluminium BTS

Size	Generic type	Number of conductors	$I_{z0}$ [A]	$r_{ph}^*$ [mΩ/m]	$x_{ph}$ [mΩ/m]	$U_r$ [V]
160	160A 4 cond. Al	4	160	0.591	0.260	1000
160	160A 5 cond. Al	5	160	0.591	0.260	1000
160	160A 4 cond. Al	4	160	0.431	0.260	500
160	160A 5 cond. Al	5	160	0.431	0.260	500
250	250A 4 cond. Al	4	250	0.394	0.202	1000
250	250A 5 cond. Al	5	250	0.394	0.202	1000
250	250A 4 cond. Al	4	250	0.226	0.202	500
250	250A 5 cond. Al	5	250	0.226	0.202	500
315	315A 4 cond. Al	4	315	0.236	0.186	1000
315	315A 5 cond. Al	5	315	0.236	0.186	1000
315	315A 4 cond. Al	4	315	0.181	0.186	500
315	315A 5 cond. Al	5	315	0.181	0.186	500
400	400A 4 cond. Al	4	400	0.144	0.130	1000
400	400A 5 cond. Al	5	400	0.144	0.130	1000
400	400A 4 cond. Al	4	400	0.125	0.130	500
400	400A 5 cond. Al	5	400	0.125	0.130	500
500	500A 4 cond. Al	4	500	0.102	0.127	500
500	500A 5 cond. Al	5	500	0.102	0.127	500
630	630A 4 cond. Al	4	630	0.072	0.097	1000
630	630A 5 cond. Al	5	630	0.072	0.097	1000
630	630A 4 cond. Al	4	630	0.072	0.029	1000
630	630A 4 cond. Al	4	630	0.073	0.097	500
630	630A 5 cond. Al	5	630	0.073	0.097	500
800	800A 4 cond. Al	4	800	0.062	0.096	1000

## 2 Protection of feeders

Size	Generic type	Number of conductors	$I_{z0}$ [A]	$r_{ph}^*$ [mΩ/m]	$x_{ph}$ [mΩ/m]	$U_r$ [V]
800	800A 5 cond. Al	5	800	0.062	0.096	1000
800	800A 4 cond. Al	4	800	0.067	0.027	1000
800	800A 4 cond. Al	4	800	0.071	0.096	500
800	800A 5 cond. Al	5	800	0.071	0.096	500
1000	1000A 4 cond. Al	4	1000	0.062	0.023	1000
1000	1000A 4 cond. Al	4	1000	0.068	0.087	1000
1200	1200A 4 cond. Al	4	1200	0.054	0.023	1000
1250	1250A 4 cond. Al	4	1250	0.044	0.021	1000
1250	1250A 4 cond. Al	4	1250	0.044	0.066	1000
1500	1500A 4 cond. Al	4	1500	0.041	0.023	1000
1600	1600A 4 cond. Al	4	1600	0.035	0.017	1000
1600	1600A 4 cond. Al	4	1600	0.041	0.066	1000
2000	2000A 4 cond. Al	4	2000	0.029	0.016	1000
2000	2000A 4 cond. Al	4	2000	0.034	0.053	1000
2250	2250A 4 cond. Al	4	2250	0.032	0.049	1000
2400	2400A 4 cond. Al	4	2400	0.028	0.012	1000
2500	2500A 4 cond. Al	4	2500	0.022	0.011	1000
2500	2500A 4 cond. Al	4	2500	0.022	0.034	1000
3000	3000A 4 cond. Al	4	3000	0.020	0.011	1000
3200	3200A 4 cond. Al	4	3200	0.017	0.009	1000
3200	3200A 4 cond. Al	4	3200	0.020	0.034	1000
4000	4000A 4 cond. Al	4	4000	0.014	0.008	1000
4000	4000A 4 cond. Al	4	4000	0.017	0.024	1000
4500	4500A 4 cond. Al	4	4500	0.014	0.024	1000

\*phase resistance at  $I_{z0}$

## 2 Protection of feeders

### BTS protection

#### Protection against overload

BTSs are protected against overload by using the same criterion as that used for the cables. The following formula shall be verified:

$$I_b \leq I_n \leq I_z \quad (3)$$

where:

- $I_b$  is the current for which the circuit is designed;
- $I_n$  is the rated current of the protective device; for adjustable protective devices, the rated current  $I_n$  is the set current;
- $I_z$  is the continuous current carrying capacity of the BTS.

NOTE - The protection against short-circuit does not need to be checked if MCBs up to 63 A are used whenever correctly dimensioned for overload protection. In such cases, in fact, protection against both thermal and electrodynamic effects is certainly adequate because of the energy and peak limitations offered by these protective devices.

#### Protection against short-circuit

The BTS must be protected against thermal overload and electrodynamic effects due to the short-circuit current.

##### Protection against thermal overload

The following formula shall be fulfilled:

$$I^2 t_{CB} \leq I^2 t_{BTS} \quad (4)$$

where:

- $I^2 t_{CB}$  is the specific let-through energy of the circuit-breaker at the maximum short-circuit current value at the installation point. This can be extrapolated from the curves shown in Volume 1 Chapter 3.4;
- $I^2 t_{BTS}$  is the withstood energy of the BTS and it is normally given by the manufacturer (see Tables 4 and 5).

##### Protection against electrodynamic effects

The following formula shall be fulfilled:

$$I_{kp\ CB} \leq I_{kp\ BTS} \quad (5)$$

where:

- $I_{kp\ CB}$  is the peak limited by the circuit-breaker at the maximum short-circuit current value at the installation point. This can be extrapolated from the limitation curves shown in Volume 1, Chapter 3.3;
- $I_{kp\ BTS}$  is the maximum peak current value of the BTS (see Tables 4 and 5).

## 2 Protection of feeders

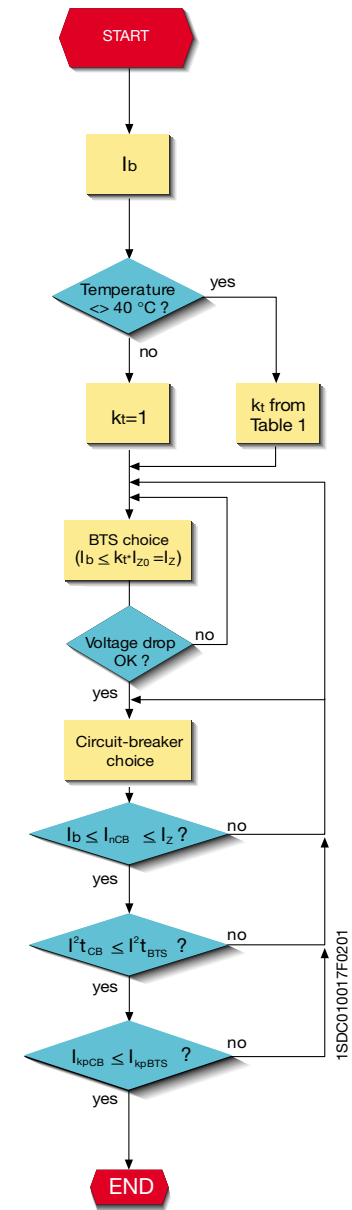

## 2 Protection of feeders

Table 4: Values of the withstood energy and peak current of copper BTS

Size	Generic type	$I^2t_{ph}$ [(kA) <sup>2</sup> s]	$I^2t_N$ [(kA) <sup>2</sup> s]	$I^2t_{pE}$ [(kA) <sup>2</sup> s]	$I_{peakph}$ [kA]	$I_{peakN}$ [kA]
25	25A 4 cond. Cu	0.48	0.48	0.48	10	10
25	25A 4 cond. Cu	0.64	0.64	0.64	10	10
25	25A 4+4 cond. Cu	0.64	0.64	0.64	10	10
40	40A 4 cond. Cu	0.73	0.73	0.73	10	10
40	40A 4 cond. Cu	1	1	1	10	10
40	40A 4+4 cond. Cu	1	1	1	10	10
40	40A 4 cond. Cu	7.29	7.29	7.29	10	10
63	63A 4 cond. Cu	7.29	7.29	7.29	10	10
100	100A 4 cond. Cu	20.25	20.25	20.25	10	10
160	160A 4 cond. Cu	30.25	30.25	30.25	10	10
160	160A 4 cond. Cu	100	60	60	17	10.2
160	160A 5 cond. Cu	100	100	100	17	10.2
160	160A 4 cond. Cu	100	100	100	17	10.2
250	250A 4 cond. Cu	312.5	187.5	187.5	52.5	31.5
250	250A 5 cond. Cu	312.5	312.5	312.5	52.5	31.5
250	250A 4 cond. Cu	169	101.4	101.4	26	15.6
250	250A 5 cond. Cu	169	169	169	26	15.6
250	250A 4 cond. Cu	169	169	169	26	15.6
315	315A 4 cond. Cu	312.5	187.5	187.5	52.5	31.5
315	315A 5 cond. Cu	312.5	312.5	312.5	52.5	31.5
350	350A 4 cond. Cu	169	101.4	101.4	26	15.6
350	350A 5 cond. Cu	169	169	169	26	15.6
350	350A 4 cond. Cu	169	169	169	26	15.6
400	400A 4 cond. Cu	900	540	540	63	37.8
400	400A 5 cond. Cu	900	900	900	63	37.8
500	500A 4 cond. Cu	756.25	453.75	453.75	58	34.8
500	500A 5 cond. Cu	756.25	756.25	756.25	58	34.8
500	500A 4 cond. Cu	756.25	756.25	756.25	58	34.8
630	630A 4 cond. Cu	1296	777.6	777.6	75.6	45.4
630	630A 5 cond. Cu	1296	1296	1296	75.6	45.4
700	700A 4 cond. Cu	756.25	453.75	453.75	58	34.8
700	700A 5 cond. Cu	756.25	756.25	756.25	58	34.8
700	700A 4 cond. Cu	756.25	756.25	756.25	58	34.8

## 2 Protection of feeders

Size	Generic type	$I^2t_{ph}$ [(kA) <sup>2</sup> s]	$I^2t_N$ [(kA) <sup>2</sup> s]	$I^2t_{pE}$ [(kA) <sup>2</sup> s]	$I_{peakph}$ [kA]	$I_{peakN}$ [kA]
800	800A 4 cond. Cu	1296	777.6	777.6	75.6	45.4
800	800A 5 cond. Cu	1296	1296	1296	75.6	45.4
800	800A 4 cond. Cu	3969	3969	2381.4	139	83.4
800	800A 4 cond. Cu	756.25	453.75	453.75	58	34.8
800	800A 5 cond. Cu	756.25	756.25	756.25	58	34.8
800	800A 4 cond. Cu	756.25	756.25	756.25	58	34.8
1000	1000A 4 cond. Cu	1296	777.6	777.6	75.6	45.4
1000	1000A 5 cond. Cu	1296	1296	1296	75.6	45.4
1000	1000A 4 cond. Cu	3969	3969	2381.4	139	83.4
1000	1000A 4 cond. Cu	1600	1600	960	84	50.4
1000	1000A 4 cond. Cu	1024	614.4	614.4	60	36
1000	1000A 5 cond. Cu	1024	1024	1024	60	36
1000	1000A 4 cond. Cu	1024	1024	1024	60	36
1200	1200A 4 cond. Cu	7744	7744	4646.4	194	116.4
1250	1250A 4 cond. Cu	7744	7744	4646.4	194	116.4
1250	1250A 4 cond. Cu	2500	2500	1500	105	63
1500	1500A 4 cond. Cu	7744	7744	4646.4	194	116.4
1600	1600A 4 cond. Cu	7744	7744	4646.4	194	116.4
1600	1600A 4 cond. Cu	2500	2500	1500	105	63
2000	2000A 4 cond. Cu	7744	7744	4646.4	194	116.4
2000	2000A 4 cond. Cu	3600	3600	2160	132	79.2
2400	2400A 4 cond. Cu	7744	7744	4646.4	194	116.4
2500	2500A 4 cond. Cu	7744	7744	4646.4	194	116.4
2500	2500A 4 cond. Cu	4900	4900	2940	154	92.4
3000	3000A 4 cond. Cu	30976	30976	18585.6	387	232.2
3000	3000A 4 cond. Cu	8100	8100	4860	198	118.8
3200	3200A 4 cond. Cu	30976	30976	18585.6	387	232.2
3200	3200A 4 cond. Cu	8100	8100	4860	198	118.8
4000	4000A 4 cond. Cu	30976	30976	18585.6	387	232.2
4000	4000A 4 cond. Cu	8100	8100	4860	198	118.8
5000	5000A 4 cond. Cu	30976	30976	18585.6	387	232.2
5000	5000A 4 cond. Cu	10000	10000	6000	220	132

## 2 Protection of feeders

Table 5: Values of the withstood energy and peak current of aluminium BTS

Size	Generic type	$I_{ph}^2 t_{ph}$ [(kA) <sup>2</sup> s]	$I_{N}^2 t_{N}$ [(kA) <sup>2</sup> s]	$I_{PE}^2 t_{PE}$ [(kA) <sup>2</sup> s]	$I_{peakph}$ [kA]	$I_{peakN}$ [kA]
160	160A 4 cond. Al	112.5	67.5	67.5	30	18
160	160A 5 cond. Al	112.5	112.5	112.5	30	18
160	160A 4 cond. Al	100	60	60	17	10.2
160	160A 5 cond. Al	100	100	100	17	10.2
160	160A 4 cond. Al	100	100	100	17	10.2
250	250A 4 cond. Al	312.5	187.5	187.5	52.5	31.5
250	250A 5 cond. Al	312.5	312.5	312.5	52.5	31.5
250	250A 4 cond. Al	169	101.4	101.4	26	15.6
250	250A 5 cond. Al	169	169	169	26	15.6
250	250A 4 cond. Al	169	169	169	26	15.6
315	315A 4 cond. Al	625	375	375	52.5	31.5
315	315A 5 cond. Al	625	625	625	52.5	31.5
315	315A 4 cond. Al	169	101.4	101.4	26	15.6
315	315A 5 cond. Al	169	169	169	26	15.6
315	315A 4 cond. Al	169	169	169	26	15.6
400	400A 4 cond. Al	900	540	540	63	37.8
400	400A 5 cond. Al	900	900	900	63	37.8
400	400A 4 cond. Al	625	375	375	52.5	31.5
400	400A 5 cond. Al	625	625	625	52.5	31.5
400	400A 4 cond. Al	625	625	625	52.5	31.5
500	500A 4 cond. Al	625	375	375	52.5	31.5
500	500A 5 cond. Al	625	625	625	52.5	31.5
500	500A 4 cond. Al	625	625	625	52.5	31.5
630	630A 4 cond. Al	1296	777.6	777.6	75.6	45.4
630	630A 5 cond. Al	1296	1296	1296	75.6	45.4
630	630A 4 cond. Al	1444	1444	866.4	80	48
630	630A 4 cond. Al	1024	614.4	614.4	67.5	40.5
630	630A 5 cond. Al	1024	1024	1024	67.5	40.5

## 2 Protection of feeders

Size	Generic type	$I_{ph}^2 t_{ph}$ [(kA) <sup>2</sup> s]	$I_{N}^2 t_{N}$ [(kA) <sup>2</sup> s]	$I_{PE}^2 t_{PE}$ [(kA) <sup>2</sup> s]	$I_{peakph}$ [kA]	$I_{peakN}$ [kA]
630	630A 4 cond. Al	1024	1024	1024	67.5	40.5
800	800A 4 cond. Al	1296	777.6	777.6	75.6	45.4
800	800A 5 cond. Al	1296	1296	1296	75.6	45.4
800	800A 4 cond. Al	1764	1764	1058.4	88	52.8
800	800A 4 cond. Al	1024	614.4	614.4	67.5	40.5
800	800A 5 cond. Al	1024	1024	1024	67.5	40.5
800	800A 4 cond. Al	1024	1024	1024	67.5	40.5
1000	1000A 4 cond. Al	6400	6400	3840	176	105.6
1000	1000A 4 cond. Al	1600	1600	960	84	50.4
1200	1200A 4 cond. Al	6400	6400	3840	176	105.6
1250	1250A 4 cond. Al	6400	6400	3840	176	105.6
1250	1250A 4 cond. Al	2500	2500	1500	105	63
1500	1500A 4 cond. Al	6400	6400	3840	176	105.6
1600	1600A 4 cond. Al	6400	6400	3840	176	105.6
1600	1600A 4 cond. Al	2500	2500	1500	105	63
2000	2000A 4 cond. Al	6400	6400	3840	176	105.6
2000	2000A 4 cond. Al	3600	3600	2160	132	79.2
2250	2250A 4 cond. Al	4900	4900	2940	154	92.4
2400	2400A 4 cond. Al	25600	25600	15360	352	211.2
2500	2500A 4 cond. Al	25600	25600	15360	352	211.2
2500	2500A 4 cond. Al	8100	8100	4860	198	118.8
3000	3000A 4 cond. Al	25600	25600	15360	352	211.2
3200	3200A 4 cond. Al	25600	25600	15360	352	211.2
3200	3200A 4 cond. Al	8100	8100	4860	198	118.8
4000	4000A 4 cond. Al	25600	25600	15360	352	211.2
4000	4000A 4 cond. Al	8100	8100	4860	198	118.8
4500	4500A 4 cond. Al	10000	10000	6000	220	132

## 2 Protection of feeders

### Protection of the outgoing feeders

If the outgoing feeder, which generally consists of cable duct, is not already protected against short-circuit and overload by the device located upstream of the cable, the following measures shall be taken:

- *protection against short-circuit:*

there is no need to protect the feeder against the short-circuit if simultaneously:

- the length does not exceed 3 metres;
- the risk of short-circuit is minimized;
- there is no inflammable material nearby.

In explosive environments and environments with greater risk of fire, protection against short-circuit is always required;

- *protection against overload:*

the current carrying capacity of the feeder is generally lower than that of the BTS. It is therefore necessary to protect also the feeder against overload.

The protection device against overload can be placed inside the pull box or on the incoming panel.

In the latter case, protection against overload can also be provided by the circuit-breakers protecting the single outgoing feeder from the panel only if the sum of their rated currents is lower or equal to the current carrying capacity  $I_z$  of the outgoing feeder.

In locations with greater risk of fire, the overload protection device shall be installed at the outgoing point, i.e. inside the pull box.

### Voltage drop

If a BTS is particularly long, the value of the voltage drop must be verified. For three-phase systems with a power factor ( $\cos\varphi_m$ ) not lower than 0.8, the voltage drop can be calculated by using the following simplified formula:

$$\Delta u = \frac{a \cdot \sqrt{3} \cdot I_b \cdot L \cdot (r_t \cdot \cos\varphi_m + x \cdot \sin\varphi_m)}{1000} \text{ [V]} \quad (6a)$$

For single-phase BTS the formula is:

$$\Delta u = \frac{a \cdot 2 \cdot I_b \cdot L \cdot (r_t \cdot \cos\varphi_m + x \cdot \sin\varphi_m)}{1000} \text{ [V]} \quad (6b)$$

where:

- $a$  is the current distribution factor, which depends on the circuit supply and the arrangement of the electric loads along the BTS, as shown in Table 6:

## 2 Protection of feeders

Table 6: Current distribution factor

Type of supply	Arrangement of loads	Current distribution factor
From one end only	Load concentrated at the end	1
	Evenly distributed load	0.5
From both ends	Evenly distributed load	0.25
Central	Load concentrated at the ends	0.25
	Evenly distributed load	0.125

- $I_b$  is the load current [A];
- $L$  is the BTS length [m];
- $r_t$  is the phase resistance per unit of length of BTS, measured under thermal steady-state conditions [ $m\Omega/m$ ];
- $x$  is the phase reactance per unit of length of BTS [ $m\Omega/m$ ];
- $\cos\varphi_m$  is average power factor of the loads.

Percentage voltage drop is obtained from:

$$\Delta u\% = \frac{\Delta u}{U_r} \cdot 100 \quad (7)$$

where  $U_r$  is rated voltage.

To reduce the voltage drop in very long BTS the power can be supplied at an intermediate position rather than at the end (see Table 6).

### Calculation of voltage drop for unevenly distributed loads

If the loads cannot be considered to be evenly distributed, the voltage drop can be calculated more accurately by using the formulas below.

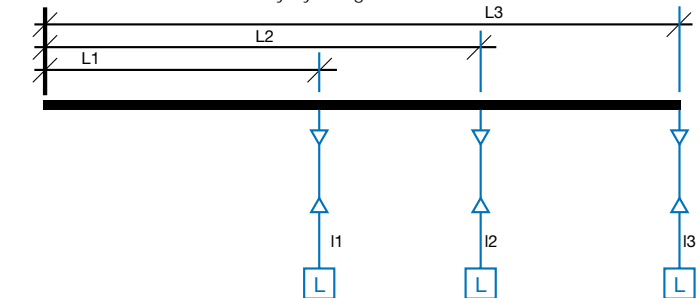

For the distribution of the three-phase loads shown in the figure, the voltage drop can be calculated by the following formula if the BTS has a constant cross section (as usual):

$$\Delta u = \sqrt{3} [r_t (I_1 L_1 \cos\varphi_1 + I_2 L_2 \cos\varphi_2 + I_3 L_3 \cos\varphi_3) + x (I_1 L_1 \sin\varphi_1 + I_2 L_2 \sin\varphi_2 + I_3 L_3 \sin\varphi_3)]$$

## 2 Protection of feeders

Generally speaking, this formula becomes:

$$\Delta u = \frac{\sqrt{3} \cdot r_t \cdot \sum I_i \cdot L_i \cdot \cos \varphi_{mi} + x \cdot \sum I_i \cdot L_i \cdot \sin \varphi_{mi}}{1000} \text{ [V]} \quad (8)$$

where:

- $r_t$  is the phase resistance per unit of length of BTS, measured under thermal steady-state conditions [mΩ/m];
- $x$  is the phase reactance per unit of length of BTS [mΩ/m];
- $\cos \varphi_m$  is average power factor of the  $i$ -th load;
- $I_i$  is  $i$ -th load current [A];
- $L_i$  is the distance of the  $i$ -th load from the beginning of the BTS [m].

### Joule-effect losses

Joule-effect losses are due to the electrical resistance of the BTS. The losses are dissipated in heat and contribute to the heating of the trunking and of the environment. Calculation of power losses is useful for correctly dimensioning the air-conditioning system for the building. Three-phase losses are:

$$P_j = \frac{3 \cdot r_t \cdot I_b^2 \cdot L}{1000} \text{ [W]} \quad (9a)$$

while single-phase losses are:

$$P_j = \frac{2 \cdot r_t \cdot I_b^2 \cdot L}{1000} \text{ [W]} \quad (9b)$$

where:

- $I_b$  is the current used [A];
- $r_t$  is the phase resistance per unit of length of BTS measured under thermal steady-state conditions [mΩ/m];
- $L$  is the length of BTS [m].

For accurate calculations, losses must be assessed section by section on the basis of the currents flowing through them; e.g. in the case of distribution of loads shown in the previous figure:

	Length	Current	Losses
1° section	$L_1$	$I_1 + I_2 + I_3$	$P_1 = 3r_t L_1 (I_1 + I_2 + I_3)^2$
2° section	$L_2 - L_1$	$I_2 + I_3$	$P_2 = 3r_t (L_2 - L_1) (I_2 + I_3)^2$
3° section	$L_3 - L_2$	$I_3$	$P_3 = 3r_t (L_3 - L_2) (I_3)^2$
Total losses in BTS			$P_{tot} = P_1 + P_2 + P_3$

## 3 Protection of electrical equipment

### 3.1 Protection and switching of lighting circuits

#### Introduction

Upon supply of a lighting installation, for a brief period an initial current exceeding the rated current (corresponding to the power of the lamps) circulates on the network. This possible peak has a value of approximately 15+20 times the rated current, and is present for a few milliseconds; there may also be an inrush current with a value of approximately 1.5+3 times the rated current, lasting up to some minutes. The correct dimensioning of the switching and protection devices must take these problems into account.

Peak current diagram

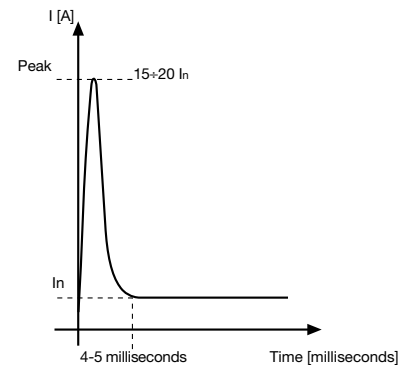

Inrush current diagram

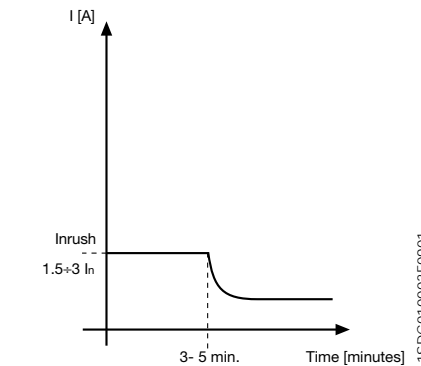

1SDC010003F0901

The most commonly used lamps are of the following types:

- incandescent;
- halogen;
- fluorescent;
- high intensity discharge: mercury vapour, metal halide and sodium vapour.

### Incandescent lamps

Incandescent lamps are made up of a glass bulb containing a vacuum or inert gas and a tungsten filament. The current flows through this filament, heating it until light is emitted.

The electrical behaviour of these lamps involves a high peak current, equal to approximately 15 times the rated current; after a few milliseconds the current returns to the rated value. The peak is caused by the lamp filament which, initially cold, presents a very low electrical resistance. Subsequently, due to the very fast heating of the element, the resistance value increases considerably, causing the decrease in the current absorbed.

### 3 Protection of electrical equipment

#### Halogen lamps

Halogen lamps are a special type of incandescent lamp in which the gas contained within the bulb prevents the vaporized material of the tungsten filament from depositing on the surface of the bulb and forces re-deposition on the filament. This phenomenon slows the deterioration of the filament, improves the quality of the light emitted and increases the life of the lamp. The electrical behaviour of these lamps is the same as that of incandescent lamps.

#### Fluorescent lamps

Fluorescent lamps are a so-called discharge light source. The light is produced by a discharge within a transparent enclosure (glass, quartz, etc. depending on the type of lamp) which contains mercury vapour at low pressure.

Once the discharge has started, the gas within the enclosure emits energy in the ultraviolet range which strikes the fluorescent material; in turn, this material transforms the ultraviolet radiation into radiation which has a wavelength within the visible spectrum. The colour of the light emitted depends upon the fluorescent material used.

The discharge is created by an appropriate peak in voltage, generated by a starter. Once the lamp has been switched on, the gas offers an ever lower resistance, and it is necessary to stabilize the intensity of the current, using a controller (reactor); this lowers the power factor to approximately 0.4+0.6; normally a capacitor is added to increase the power factor to a value of more than 0.9

There are two types of controllers, magnetic (conventional) and electronic, which absorb from 10% to 20% of the rated power of the lamp. Electronic controllers offer specific advantages such as a saving in the energy absorbed, a lower dissipation of heat, and ensure a stable, flicker-free light. Some types of fluorescent lamps with electronic reactors do not need a starter.

*Compact fluorescent lamps* are made up of a folded tube and a plastic base which contains, in some cases, a conventional or electronic controller.

The value of the inrush current depends upon the presence of a power factor correction capacitor:

- non PFC lamps have inrush currents equal to approximately twice the rated current and a turn-on time of about ten seconds;
- in PFC lamps, the presence of the capacitor allows the reduction of the turn-on time to a few seconds, but requires a high peak current, determined by the charge of the capacitor, which can reach 20 times the rated current.

If the lamp is fitted with an electronic controller, the initial transient current may lead to peak currents equal to, at maximum, 10 times the rated current.

### 3 Protection of electrical equipment

#### High intensity discharge lamps: mercury vapour, metal halide and sodium vapour

The functioning of high intensity discharge lamps is the same as that of fluorescent lamps with the difference that the discharge occurs in the presence of a gas at high pressure. In this case, the arc is able to vaporize the metallic elements contained in the gas, releasing energy in the form of radiation which is both ultraviolet and within the visible spectrum. The special type of bulb glass blocks the ultraviolet radiation and allows only the visible radiation to pass through. There are three main types of high intensity discharge lamps: mercury vapour, metal halide and sodium vapour. The colour characteristics and the efficiency of the lamp depend upon the different metallic elements present in the gas, which are struck by the arc.

High intensity discharge lamps require a suitably sized controller and a heating period which can last some minutes before the emission of the rated light output. A momentary loss of power makes the restarting of the system and the heating necessary.

Non PFC lamps have inrush currents of up to twice the rated current for approximately 5 minutes.

PFC lamps have a peak current equal to 20 times the rated current, and an inrush current of up to twice the rated current for approximately 5 minutes.

Lamp type		Peak current	Inrush current	Turn-on time
Incandescent lamps		15In	-	-
Halogen lamps		15In	-	-
Fluorescent lamp	Non PFC	-	2In	10 s
	PFC	20In	-	1+6 s
High intensity discharge lamps	Non PFC	-	2In	2+8 min
	PFC	20In	2In	2+8 min

#### Protection and switching devices

IEC 60947-4-1 identifies two specific utilization categories for lamp control contactors:

- AC-5a switching of electric discharge lamps;
- AC-5b switching of incandescent lamps.

The documentation supplied by the manufacturer includes tables for contactor selection, according to the number of lamps to be controlled, and to their type.



### 3 Protection of electrical equipment

For the selection of a protection device the following verifications shall be carried out:

- the trip characteristic curve shall be above the turning-on characteristic curve of the lighting device to avoid unwanted trips; an approximate example is shown in Figure1;
- coordination shall exist with the contactor under short-circuit conditions (lighting installations are not generally characterized by overloads).

With reference to the above verification criteria, the following tables show the maximum number of lamps per phase which can be controlled by the combination of ABB circuit-breakers and contactors for some types of lamps, according to their power and absorbed current  $I_b^{(*)}$ , for three phase installations with a rated voltage of 400 V and a maximum short-circuit current of 15 kA.

(\*) For calculation see Annex B Calculation of load current  $I_b$

**Table 1: Incandescent and halogen lamps**

Ur= 400 V		I <sub>k</sub> = 15 kA											
Incandescent/halogen lamps													
Circuit-breaker type		S200M D20	S200M D20	S200M D25	S200M D32	S200M D50		T2N160 In63	T2N160 In63	T2N160 In100	T2N160 In100	T2N160 In100	T2N160 In160
Setting PR221 DS		----	----	----	----	----		L= 0.68- A S= 8- B	L= 0.92- A S= 10- B	L= 0.68- A S= 8- B	L= 0.76- A S= 8- B	L= 1- A S= 10- B	L= 0.68- A S= 7- B
Contactor type		A26	A26	A26	A26	A30		A40	A50	A63	A75	A95	A110
Rated Power [W]	Rated current I <sub>b</sub> [A]	N° lamps per phase											
60	0.27	57	65	70	103	142		155	220	246	272	355	390
100	0.45	34	38	42	62	85		93	132	147	163	210	240
200	0.91	17	19	20	30	42		46	65	73	80	105	120
300	1.37	11	12	13	20	28		30	43	48	53	70	80
500	2.28	6	7	8	12	16		18	26	29	32	42	48
1000	4.55	3	4	4	6	8		9	13	14	16	21	24

### 3 Protection of electrical equipment

**Figure 1: Approximate diagram for the coordination of lamps with protection and switching devices**

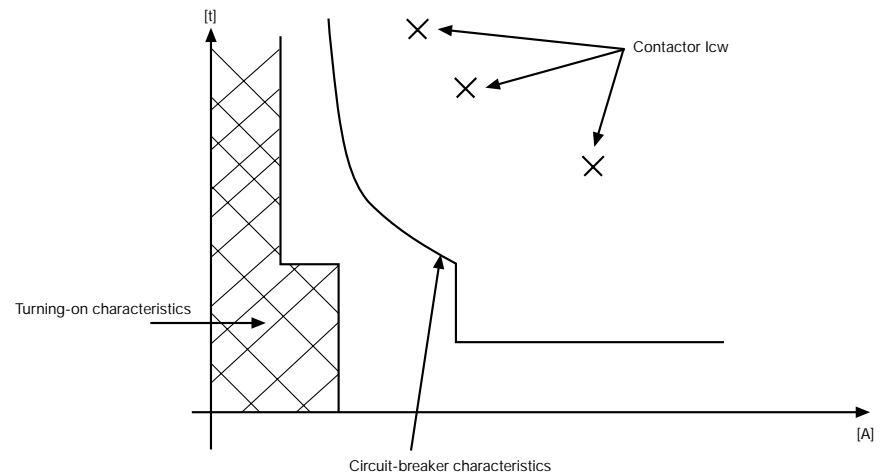

### 3 Protection of electrical equipment

Table 2: Fluorescent lamps

Ur= 400 V		Ik= 15 kA											
Fluorescent lamps non PFC													
Circuit-breaker type		S200M D16	S200M D20	S200M D20	S200M D32	S200M D40		S200M D50	S200M D63	T2N160 In100	T2N160 In100	T2N160 In100	T2N160 In160
Setting PR221 DS										L= 0.68- A S= 10- B	L= 0.76- A S= 10- B	L= 0.96- A- S= 10- B	S= 0.68- A S= 10- B
Contactor type		A26	A26	A26	A26	A30		A40	A50	A63	A75	A95	A110
Rated Power [W]	Rated current Ib [A]	N° lamps per phase											
20	0.38	40	44	50	73	100		110	157	173	192	250	278
40	0.45	33	37	42	62	84		93	133	145	162	210	234
65	0.7	21	24	27	40	54		60	85	94	104	135	150
80	0.8	18	21	23	35	47		52	75	82	91	118	132
100	1.15	13	14	16	24	33		36	52	57	63	82	92
110	1.2	12	14	15	23	31		35	50	55	60	79	88

TSDC010039F0201

Ur= 400 V			Ik= 15 kA										
Fluorescent lamps PFC													
Circuit-breaker type			S200M D25	S200M D25	S200M D32	S200M D40	S200M D63		T2N160 In63	T2N160 In63	T2N160 In100	T2N160 In100	T2N160 In100
Setting PR221 DS			---	---	---	---	---		L= 0.68- A S= 8- B	L= 1- A S= 10- B	L= 0.68- A S= 10- B	L= 0.76- A S= 10- B	L= 0.96- A S= 10- B
Contactor type			A26	A26	A26	A26	A30		A40	A50	A63	A75	A95
Rated Power [W]	Rated current Ib [A]	Capacitor [μF]	N° lamps per phase										
20	0.18	5	83	94	105	155	215		233	335	360	400	530
40	0.26	5	58	65	75	107	150		160	230	255	280	365
65	0.42	7	35	40	45	66	92		100	142	158	173	225
80	0.52	7	28	32	36	53	74		80	115	126	140	180
100	0.65	16	23	26	29	43	59		64	92	101	112	145
110	0.7	18	21	24	27	40	55		59	85	94	104	135

### 3 Protection of electrical equipment

Table 3: High intensity discharge lamps

Ur= 400 V		Ik= 15 kA											
Fluorescent lamps non PFC													
Circuit-breaker type		S200M D16	S200M D20	S200M D20	S200M D32	S200M D40		S200M D40	S200M D50	S200M	T2N160 In100	T2N160 In100	T2N160 In160
Setting PR221 DS											L= 0.8- B S= 6.5- B	L= 1- B S= 8- B	L= 0.8- B S= 6.5- B
Contactor type		A26	A26	A26	A26	A30		A40	A50	A63	A75	A95	A110
Rated Power [W]	Rated current Ib [A]	N° lamps per phase											
150	1.8	6	7	8	11	15		17	23	26	29	38	41
250	3	4	4	5	7	9		10	14	16	17	23	25
400	4.4	3	3	3	4	6		7	9	10	12	15	17
600	6.2	1	2	2	3	4		5	7	8	8	11	12
1000	10.3	-	1	1	2	3		3	4	5	5	6	7

Ur= 400 V			Ik= 15 kA											
Fluorescent lamps PFC														
Circuit-breaker type			S200M D16	S200M D20	S200M D20	S200M D32	S200M D40		S200M D40	T2N160 In100	T2N160 In100	T2N160 In100	T2N160 In160	T2N160 In160
Setting PR221 DS			---	---	---	---	---		---	L= 0.8- B S= 6.5- B	L= 0.88- B S= 6.5- B	L= 1- B S= 6.5- B	L= 0.84- B S= 4.5- B	L= 0.88- B S= 4.5- B
Contactor type			A26	A26	A26	A26	A30		A40	A50	A63	A75	A95	A110
Rated Power [W]	Rated current Ib [A]	Capacitor [μF]	N° lamps per phase											
150	1	20	13	14	15	23	28		30	50	58	63	81	88
250	1.5	36	8	9	10	15	18		20	33	38	42	54	59
400	2.5	48	5	5	6	9	11		12	20	23	25	32	36
600	3.3	65	4	4	5	7	8		9	15	17	19	24	27
1000	6.2	100	-	-	-	4	4		5	8	9	10	13	14

1SD0010034F0201

**Example:**

Switching and protection of a lighting system, supplied by a three phase network at 400 V 15 kA, made up of 55 incandescent lamps, of 200 W each, per phase. In Table 1, on the row corresponding to 200 W, select the cell showing the number of controllable lamps immediately above the number of lamps per phase present in the installation. In the specific case, corresponding to the cell for 65 lamps per phase the following equipment are suggested:

- ABB Tmax T2N160 In63 circuit-breaker with PR221/DS type electronic release, with protection L set at 0.92, curve A and protection S set at 10, curve B;
- A50 contactor.

## 3 Protection of electrical equipment

### 3.2 Protection and switching of generators

The need to guarantee an ever greater continuity of service has led to an increase in the use of emergency supply generators, either as an alternative to, or in parallel with the public utility supply network.

Typical configurations include:

- "Island supply" (independent functioning) of the priority loads in the case of a lack of energy supply through the public network;
- supply to the user installation in parallel with the public supply network.

Unlike the public supply network, which has a constant contribution, in case of a short-circuit, the current supplied by the generator is a function of the parameters of the machine itself, and decreases with time; it is possible to identify the following successive phases:

1. a subtransient phase: with a brief duration (10÷50 ms), characterized by the subtransient reactance  $X''_d$  (5÷20% of the rated impedance value), and by the subtransient time constant  $T''_d$  (5÷30 ms);
2. a transitory phase: may last up to some seconds (0.5÷2.5 s), and is characterized by the transitory reactance  $X'_d$  (15÷40% of the rated impedance value), and by the transitory time constant  $T'_d$  (0.03÷2.5 s);
3. a synchronous phase: may persist until the tripping of external protection, and is characterized by the synchronous reactance  $X_d$  (80÷300% of the rated impedance value).

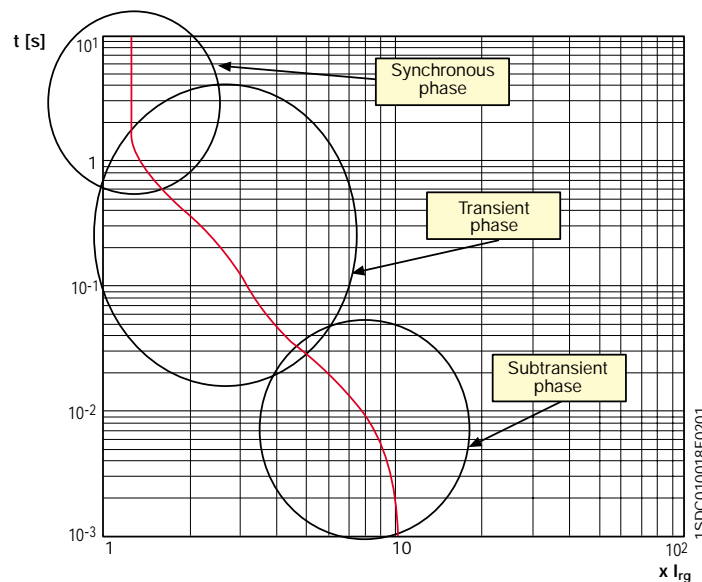

## 3 Protection of electrical equipment

As a first approximation, it can be estimated that the maximum value of the short-circuit current of a generator, with rated power  $S_{rg}$ , at the rated voltage of the installation  $U_r$ , is equal to:

$$I_{kg} = \frac{I_{rg} \cdot 100}{X''_d \%}$$

where

$I_{rg}$  is the rated current of the generator:

$$I_{rg} = \frac{S_{rg}}{\sqrt{3} \cdot U_r}$$

The circuit-breaker for the protection of the generator shall be selected according to the following criteria:

- the set current higher than the rated current of the generator:  $I_1 \geq I_{rg}$ ;
- breaking capacity  $I_{cu}$  or  $I_{cs}$  higher than the maximum value of short-circuit current at the installation point:
  - in the case of a single generator:  $I_{cu}(I_{cs}) \geq I_{kg}$ ;
  - in the case of  $n$  identical generators in parallel:  $I_{cu}(I_{cs}) \geq I_{kg} \cdot (n-1)$ ;
  - in the case of operation in parallel with the network:  $I_{cu}(I_{cs}) \geq I_{kNet}$ , as the short-circuit contribution from the network is normally greater than the contribution from the generator;
- for circuit-breakers with thermomagnetic releases: low magnetic trip threshold:  $I_3 = 2.5/3 \cdot I_n$ ;
- for circuit-breakers with electronic releases:
  - trip threshold of the delayed short-circuit protection function (S), set between 1.5 and 4 times the rated current of the generator, in such a way as to "intercept" the decrement curve of the generator:  $I_2 = (1.5 \div 4) \cdot I_{rg}$ ; if the function S is not present, function I can be set at the indicated values  $I_3 = (1.5 \div 4) \cdot I_{rg}$ ;
  - trip threshold of the instantaneous short-circuit protection function ( $I_3$ ) set at a value greater than the rated short-circuit current of the generator, so as to achieve discrimination with the devices installed downstream, and to allow fast tripping in the event of a short-circuit upstream of the device (working in parallel with other generators or with the network):

$$I_3 \geq I_{kg}$$

### 3 Protection of electrical equipment

The following tables give ABB SACE suggestions for the protection and switching of generators; the tables refer to 400 V (Table 1), 440 V (Table 2), 500 V (Table 3) and 690 V (Table 4). Molded-case circuit-breakers can be equipped with both thermomagnetic (TMG) as well as electronic releases.

**Table 1** 400 V

S <sub>ig</sub> [kVA]	MCB	MCCB	ACB
4	S200 B6	T2 160	
6	S200 B10		
7	S200 B13		
9	S200 B16		
11	S200 B25		
14	S200 B32		
17	S200 B50		
19	S200 B63		
21	S280 B80		
22	S280 B100		
28			
31			
35			
38			
42			
44			
48			
55			
69			
80			
87			
100			
111			
138			
159	T3 250 T4 250		
173			
180			
190	T4 320		
208			
218			
242	T5 400		
277			
308			
311	T5 630		
346			
381			
415			
436			
484	T6 800		
554			
692	T7 1000		
727			
865	T7 1250*		
1107	T7 1600*		
1730	E3 2500		
2180			
2214	E3 3200		
2250			
2500	E4 4000		
2800			
3150	E6 5000		
3500	E6 6300		

**Table 2** 440 V

S <sub>ig</sub> [kVA]	MCB	MCCB	ACB
4	S200 B6	T2 160	
6	S200 B8		
7	S200 B10		
9	S200 B13		
11	S200 B16		
14	S200 B20		
17	S200 B25		
19	S200 B32		
21	S200 B40		
22	S200 B50		
28	S200 B63		
31	S280 B80		
35	S280 B100		
38			
42			
44			
48			
55			
69			
80			
87			
100			
111			
138			
159			
173	T3 250 T4 250		
180			
190			
208			
218	T4 320		
242			
277	T5 400		
308			
311	T5 630		
346			
381			
415			
436			
484	T6 800		
554			
692	T7 1000		
727			
865	T7 1250*		
1107	T7 1600*		
1730	E3 2500		
2180			
2214	E3 3200		
2250			
2500	E4 3600		
2800	E4 4000		
3150	E6 5000		
3500	E6 5000		

1SDC010016F0001

\* also Isoimax CB type S7 can be used for this application  
 \*\* also Emax CB type E1 can be used for this application

### 3 Protection of electrical equipment

**Table 3** 500 V

S <sub>ig</sub> [kVA]	MCB	MCCB	ACB
4		T2 160	
6			
7			
9			
11			
14			
17			
19			
21			
22			
28			
31			
35			
38			
42			
44			
48			
55			
69			
80			
87			
100			
111			
138			
159			
173			
180			
190			
208			
218			
242			
277			
308			
311			
346			
381			
415			
436			
484			
554			
692			
727			
865			
1107			
1730			
2180			
2214			
2250			
2500			
2800			
3150			
3500			

**Table 4** 690 V

S <sub>ig</sub> [kVA]	MCB	MCCB	ACB
4		T2 160	
6			
7			
9			
11			
14			
17			
19			
21			
22			
28			
31			
35			
38			
42			
44			
48			
55			
69			
80			
87			
100			
111			
138			
159			
173			
180			
190			
208			
218			
242			
277			
308			
311			
346			
381			
415			
436			
484			
554			
692			
727			
865			
1107			
1730			
2180			
2214			
2250			
2500			
2800			
3150			
3500			

1SDC010017F0001

\* also Isoimax CB type S7 can be used for this application  
 \*\* also Emax CB type E1 can be used for this application

### 3 Protection of electrical equipment

**Example:**

Protection of a generator with  $S_{rg} = 100$  kVA, in a system with a rated voltage of 440 V.

The generator parameters are:

$U_f = 440$  V

$S_{rg} = 100$  kVA

$f = 50$  Hz

$I_{rg} = 131.2$  A

$X_d'' = 6.5$  % (subtransient reactance)

$X_d' = 17.6$  % (transient reactance)

$X_d = 230$  % (synchronous reactance)

$T_d'' = 5.5$  ms (subtransient time constant)

$T_d' = 39.3$  ms (transient time constant)

From table 2, an ABB SACE T2N160 circuit-breaker is selected, with  $I_n = 160$  A, with electronic release PR221-LS. For correct protection of the generator, the following settings are selected:

function L: 0.84 – A, corresponding to 134.4 A, value greater than  $I_{rg}$

function I: 1.5

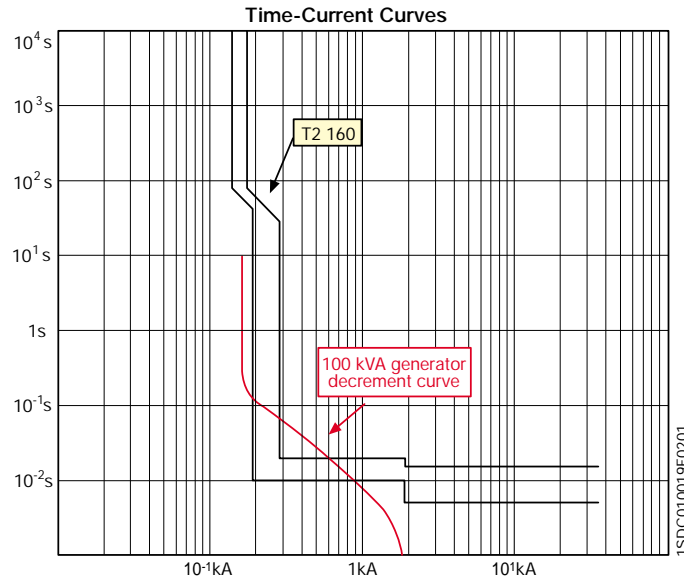

### 3 Protection of electrical equipment

#### 3.3 Protection and switching of motors

##### Electromechanical starter

The starter is designed to:

- start motors;
- ensure continuous functioning of motors;
- disconnect motors from the supply line;
- guarantee protection of motors against working overloads.

The starter is typically made up of a switching device (contactor) and an overload protection device (thermal release).

The two devices must be coordinated with equipment capable of providing protection against short-circuit (typically a circuit-breaker with magnetic release only), which is not necessarily part of the starter.

The characteristics of the starter must comply with the international Standard IEC 60947-4-1, which defines the above as follows:

**Contactor:** a mechanical switching device having only one position of rest, operated otherwise than by hand, capable of making, carrying and breaking currents under normal circuit conditions including operating overload conditions.

**Thermal release:** thermal overload relay or release which operates in the case of overload and also in case of loss of phase.

**Circuit-breaker:** defined by IEC 60947-2 as a mechanical switching device, capable of making, carrying and breaking currents under normal circuit conditions and also making, carrying for a specified time and breaking currents under specified abnormal circuit conditions.

The main types of motor which can be operated and which determine the characteristics of the starter are defined by the following utilization categories:

**Table 1: Utilization categories and typical applications**

Current type	Utilization categories	Typical applications
Alternating Current ac	AC-2	Slip-ring motors: starting, switching off
	AC-3	Squirrel-cage motors: starting, switching off during running <sup>(1)</sup>
	AC-4	Squirrel-cage motors: starting, plugging, inching

<sup>(1)</sup> AC-3 categories may be used for occasionally inching or plugging for limited time periods such as machine set-up; during such limited time periods the number of such operations should not exceed five per minutes or more than ten in a 10 minutes period.

### 3 Protection of electrical equipment

The choice of the starting method and also, if necessary, of the type of motor to be used depends on the typical resistant torque of the load and on the short-circuit power of the motor supplying network.

With alternating current, the most commonly used motor types are as follows:

- asynchronous three-phase squirrel-cage motors (AC-3): the most widespread type due to the fact that they are of simple construction, economical and sturdy; they develop high torque with short acceleration times, but require elevated starting currents;
- slip-ring motors (AC-2): characterized by less demanding starting conditions, and have quite a high starting torque, even with a supply network of low power.

#### Starting methods

The most common starting methods for asynchronous squirrel-cage motors are detailed below:

##### Direct starting

With direct starting, the DOL (Direct On Line) starter, with the closing of line contactor KL, the line voltage is applied to the motor terminals in a single operation. Hence a squirrel-cage motor develops a high starting torque with a relatively reduced acceleration time. This method is generally used with small and medium power motors which reach full working speed in a short time. These advantages are, however, accompanied by a series of drawbacks, including, for example:

- high current consumption and associated voltage drop which may cause damages to the other parts of the system connected to the network;
- violent acceleration which has negative effects on mechanical transmission components (belts, chains and mechanical joints), reducing working life.

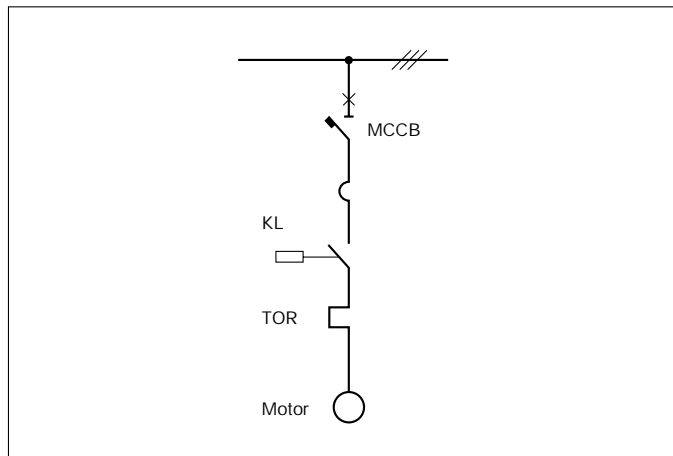

### 3 Protection of electrical equipment

Other types of starting for squirrel-cage motors are accomplished by reducing the supply voltage of the motor: this leads to a reduction in the starting current and of the motor torque, and an increase in the acceleration time.

#### Star-Delta starter

The most common reduced voltage starter is the Star-Delta starter (Y-Δ), in which:

- on starting, the stator windings are star-connected, thus achieving the reduction of peak inrush current;
- once the normal speed of the motor is nearly reached, the switchover to delta is carried out.

After the switchover, the current and the torque follow the progress of the curves associated with normal service connections (delta).

As can be easily checked, starting the motor with star-connection gives a voltage reduction of  $\sqrt{3}$ , and the current absorbed from the line is reduced by  $1/3$  compared with that absorbed with delta-connection.

The start-up torque, proportional to the square of the voltage, is reduced by 3 times, compared with the torque that the same motor would supply when delta-connected.

This method is generally applied to motors with power from 15 to 355 kW, but intended to start with a low initial resistant torque.

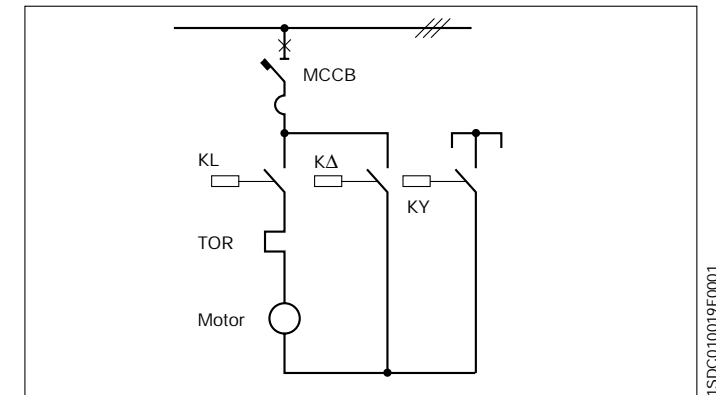

#### Starting sequence

By pressing the start button, contactors KL and KY are closed. The timer starts to measure the start time with the motor connected in star. Once the set time has elapsed, the first contact of the timer opens the KY contactor and the second contact, delayed by approximately 50 ms, closes the KΔ contactor. With this new configuration, contactors KL and KΔ closed, the motor becomes delta-connected.

### 3 Protection of electrical equipment

The thermal release TOR, inserted in the delta circuit, can detect any 3<sup>rd</sup> harmonic currents, which may occur due to saturation of the magnetic pack and by adding to the fundamental current, overload the motor without involving the line.

With reference to the connection diagram, the equipment used for a Star/Delta starter must be able to carry the following currents:

$$\frac{I_r}{\sqrt{3}} \quad \text{KL line contactor and K}\Delta \text{ delta contactor}$$

$$\frac{I_r}{3} \quad \text{KY star contactor}$$

$$\frac{I_r}{\sqrt{3}} \quad \text{overload protection release}$$

where  $I_r$  is the rated current of the motor.

#### Starting with autotransformers

Starting with autotransformers is the most functional of the methods used for reduced voltage starting, but is also the most expensive. The reduction of the supply voltage is achieved by using a fixed tap autotransformer or a more expensive multi tap autotransformer.

Applications can be found with squirrel-cage motors which generally have a power from 50 kW to several hundred kilowatts, and higher power double-cage motors.

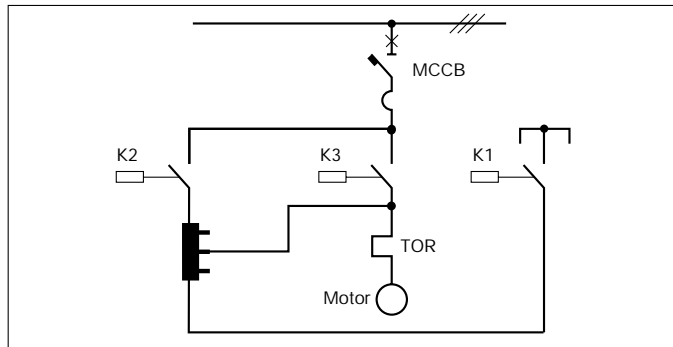

The autotransformer reduces the network voltage by the factor K ( $K=1.25+1.8$ ), and as a consequence the start-up torque is reduced by  $K^2$  times compared with the value of the full rated voltage.

On starting, the motor is connected to the taps of the autotransformer and the contactors K2 and K1 are closed.

### 3 Protection of electrical equipment

Therefore, the motor starts at a reduced voltage, and when it has reached approximately 80% of its normal speed, contactor K1 is opened and main contactor K3 is closed. Subsequently, contactor K2 is opened, excluding the autotransformer so as to supply the full network voltage.

#### Starting with inductive reactors or resistors

This type of starting is used for simple or double-cage rotors. The reduction of the supply voltage is achieved by the insertion of inductive reactors or resistors, in series to the stator. On start-up, the current is limited to 2.5+3.5 times the rated value.

On starting, the motor is supplied via contactor K2; once the normal speed is reached, the reactors are short-circuited by the closing of contactor K1, and are then excluded by the opening of contactor K2.

It is possible to achieve exclusions by step of the resistors or reactors with time-delayed commands, even for motors with power greater than 100 kW. The use of reactors notably reduces the power factor, while the use of resistors causes the dissipation of a high power (Joule effect), even if limited to the starting phase.

For a reduction K (0.6+0.8) of the motor voltage, the torque is reduced by  $K^2$  times (0.36+0.64).

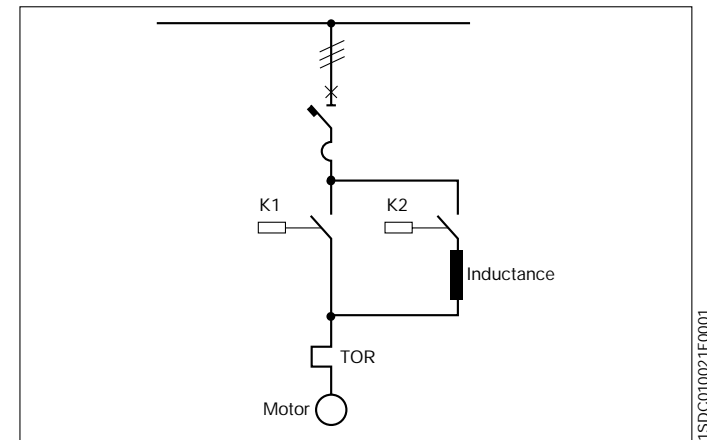

In compliance with the above mentioned Standard, starters can also be classified according to tripping time (trip classes), and according to the type of coordination achieved with the short-circuit protection device (Type 1 and Type 2).



## 3 Protection of electrical equipment

### Trip classes

The trip classes differentiate between the thermal releases according to their trip curve.

The trip classes are defined in the following table 2:

**Table 2: Trip class**

Trip Class	Tripping time in seconds (Tp)
10A	$2 < T_p \leq 10$
10	$4 < T_p \leq 10$
20	$6 < T_p \leq 20$
30	$9 < T_p \leq 30$

where  $T_p$  is the cold trip time of the thermal release at 7.2 times the set current value (for example: a release in class 10 at 7.2 times the set current value must not trip within 4 s, but must trip within 10 s).

It is normal procedure to associate class 10 with a normal start-up type, and class 30 with a heavy duty start-up type.

### Coordination type

#### Type 1

It is acceptable that in the case of short-circuit the contactor and the thermal release may be damaged. The starter may still not be able to function and must be inspected; if necessary, the contactor and/or the thermal release must be replaced, and the breaker release reset.

#### Type 2

In the case of short-circuit, the thermal release must not be damaged, while the welding of the contactor contacts is allowed, as they can easily be separated (with a screwdriver, for example), without any significant deformation.

In order to clearly determine a coordination type, and therefore the equipment necessary to achieve it, the following must be known:

- power of the motor in kW and type;
- rated system voltage;
- rated motor current;
- short-circuit current at installation point;
- starting type: DOL or Y/Δ - normal or heavy duty – Type 1 or Type 2.

The requested devices shall be coordinated with each other in accordance with the prescriptions of the Standard.

For the most common voltages and short-circuit values (400 V - 440 V - 500 V - 690 V 35 kA - 50 kA) and for the most frequently used starting types, such as direct starting and Star/Delta starting, for asynchronous squirrel-cage motor (AC-3), ABB supplies solutions with:

- magnetic circuit-breaker - contactor - thermal release;
- thermomagnetic circuit-breaker - contactor;
- thermomagnetic circuit-breaker with PR222 MP electronic release – contactor.

## 3 Protection of electrical equipment

The following is an example of the type of tables available:

**Table 3: 400 V 50 kA DOL Normal Type 2  
(Tmax – Contactor – TOR)**

Motor		MCCB		Contactor	Thermal Overload Release		
P <sub>e</sub> [kW]	I <sub>r</sub> [A]	Type	I <sub>3</sub> [A]	Type	Type	Current setting	
						min. [A]	max. [A]
0.37	1.1	T2S160 MF 1.6	21	A9	TA25DU1.4	1	1.4
0.55	1.5	T2S160 MF 1.6	21	A9	TA25DU1.8	1.3	1.8
0.75	1.9	T2S160 MF 2	26	A9	TA25DU2.4	1.7	2.4
1.1	2.8	T2S160 MF 3.2	42	A9	TA25DU4	2.8	4
1.5	3.5	T2S160 MF 4	52	A16	TA25DU5	3.5	5
2.2	5	T2S160 MF 5	65	A26	TA25DU6.5	4.5	6.5
3	6.6	T2S160 MF 8.5	110	A26	TA25DU8.5	6	8.5
4	8.6	T2S160 MF 11	145	A30	TA25DU11	7.5	11
5.5	11.5	T2S160 MF 12.5	163	A30	TA25DU14	10	14
7.5	15.2	T2S160 MA 20	210	A30	TA25DU19	13	19
11	22	T2S160 MA 32	288	A30	TA42DU25	18	25
15	28.5	T2S160 MA 52	392	A50	TA75DU42	29	42
18.5	36	T2S160 MA 52	469	A50	TA75DU52	36	52
22	42	T2S160 MA 52	547	A50	TA75DU52	36	52
30	56	T2S160 MA 80	840	A63	TA75DU80	60	80
37	68	T2S160 MA 80	960	A75	TA75DU80	60	80
45	83	T2S160 MA 100	1200	A95	TA110DU110	80	110
55	98	T3S250 MA 160	1440	A110	TA110DU110	80	110
75	135	T3S250 MA 200	1800	A145	TA200DU175	130	175
90	158	T3S250 MA 200	2400	A185	TA200DU200	150	200
110	193	T4S320 PR221-I In320	2720	A210	E320DU320	100	320
132	232	T5S400 PR221-I In400	3200	A260	E320DU320	100	320
160	282	T5S400 PR221-I In400	4000	A300	E320DU320	100	320
200	349	T5S630 PR221-I In630	5040	AF400	E500DU500	150	500
250	430	T6S630 PR221-I In630	6300	AF460	E500DU500	150	500
290	520	T6S800 PR221-I In800	7200	AF580	E800DU800	250	800
315	545	T6S800 PR221-I In800	8000	AF580	E800DU800	250	800
355	610	T6S800 PR221-I In800	8000	AF750	E800DU800	250	800

MA: magnetic only adjustable release

MF: fixed magnetic only release

### 3 Protection of electrical equipment

Table 4: 400 V 50 kA DOL Heavy duty Type 2 (Tmax – Contactor – TOR)

Motor		MCCB		Contactor	Thermal Overload Release		
P <sub>e</sub> [kW]	I <sub>r</sub> [A]	Type	I <sub>3</sub> [A]	Type	Type**	Current setting	
						No. of turns of the CT primary coil	min. [A]
0.37	1.1	T2S160 MF 1.6	21	A9	TA25DU1.4*	1	1.4
0.55	1.5	T2S160 MF 1.6	21	A9	TA25DU1.8*	1.3	1.8
0.75	1.9	T2S160 MF 2	26	A9	TA25DU2.4*	1.7	2.4
1.1	2.8	T2S160 MF 3.2	42	A9	TA25DU4*	2.8	4
1.5	3.5	T2S160 MF 4	52	A16	TA25DU5*	3.5	5
2.2	5	T2S160 MF 5	65	A26	TA25DU6.5*	4.5	6.5
3	6.6	T2S160 MF 8.5	110	A26	TA25DU8.5*	6	8.5
4	8.6	T2S160 MF 11	145	A30	TA25DU11*	7.5	11
5.5	11.5	T2S160 MF 12.5	163	A30	TA450SU60	4	10 15
7.5	15.2	T2S160 MA 20	210	A30	TA450SU60	3	13 20
11	22	T2S160 MA 32	288	A30	TA450SU60	2	20 30
15	28.5	T2S160 MA 32	392	A50	TA450SU80	2	23 40
18.5	36	T2S160 MA 52	469	A50	TA450SU80	2	23 40
22	42	T2S160 MA 52	547	A50	TA450SU60	40	60
30	56	T2S160 MA 80	840	A63	TA450SU80	55	80
37	68	T2S160 MA 80	960	A95	TA450SU80	55	80
45	83	T2S160 MA 100	1200	A110	TA450SU105	70	105
55	98	T3S250 MA 160	1440	A145	TA450SU140	95	140
75	135	T3S250 MA 200	1800	A185	TA450SU185	130	185
90	158	T3S250 MA 200	2400	A210	TA450SU185	130	185
110	193	T4S320 PR221-I In320	2720	A260	E320DU320	100	320
132	232	T5S400 PR221-I In400	3200	A300	E320DU320	100	320
160	282	T5S400 PR221-I In400	4000	AF400	E500DU500	150	500
200	349	T5S630 PR221-I In630	5040	AF460	E500DU500	150	500
250	430	T6S630 PR221-I In630	6300	AF580	E500DU500***	150	500
290	520	T6S800 PR221-I In800	7200	AF750	E800DU800	250	800
315	545	T6S800 PR221-I In800	8000	AF750	E800DU800	250	800
355	610	T6S800 PR221-I In800	8000	AF750	E800DU800	250	800

\* Provide a by-pass contactor of the same size during motor start-up  
 \*\* For type E releases choose tripping class 30  
 \*\*\* Connecting kit not available. To use the connecting kit, replacement with release E800DU800 is necessary  
 MA: magnetic only adjustable release  
 MF: fixed magnetic only release

TSDC010020F0201

### 3 Protection of electrical equipment

Table 5: 400 V 50 kA Y/Δ Normal Type 2 (Tmax – Contactor – TOR)

Motor		MCCB		Contactor			Thermal Overload Release	
P <sub>e</sub> [kW]	I <sub>r</sub> [A]	Type	I <sub>3</sub> [A]	LINE	DELTA	STAR	Type	Current setting [A]
				Type	Type	Type		
18.5	36	T2S160 MA52	469	A50	A50	A26	TA75DU25	18-25
22	42	T2S160 MA52	547	A50	A50	A26	TA75DU32	22-32
30	56	T2S160 MA80	720	A63	A63	A30	TA75DU42	29-42
37	68	T2S160 MA80	840	A75	A75	A30	TA75DU52	36-52
45	83	T2S160 MA100	1050	A75	A75	A30	TA75DU63	45 - 63
55	98	T2S160 MA100	1200	A75	A75	A40	TA75DU63	45 - 63
75	135	T3S250 MA160	1700	A95	A95	A75	TA110DU90	66 - 90
90	158	T3S250 MA200	2000	A110	A110	A95	TA110DU110	80 - 110
110	193	T3S250 MA200	2400	A145	A145	A95	TA200DU135	100 - 135
132	232	T4S320 PR221-I In320	2880	A145	A145	A110	E200DU200	60 - 200
160	282	T5S400 PR221-I In400	3600	A185	A185	A145	E200DU200	60 - 200
200	349	T5S630 PR221-I In630	4410	A210	A210	A185	E320DU320	100 - 320
250	430	T5S630 PR221-I In630	5670	A260	A260	A210	E320DU320	100 - 320
290	520	T6S630 PR221-I In630	6300	AF400	AF400	A260	E500DU500	150 - 500
315	545	T6S800 PR221-I In800	7200	AF400	AF400	A260	E500DU500	150 - 500
355	610	T6S800 PR221-I In800	8000	AF400	AF400	A260	E500DU500	150 - 500

MA: magnetic only adjustable release

Table 6: 400 V 50 kA DOL Normal and Heavy duty Type 2 (Tmax with MP release-Contactor)

Motor		MCCB			Contactor	Group
P <sub>e</sub> [kW]	I <sub>r</sub> [A]	Type	I <sub>1</sub> * range [A]	I <sub>3</sub> [A]	Type	[A]
37	68	T4S250 PR222MP In100	40-100	700	A95	95
45	83	T4S250 PR222MP In100	40-100	800	A95	95
55	98	T4S250 PR222MP In160	64-160	960	A145	145
75	135	T4S250 PR222MP In160	64-160	1280	A145	145
90	158	T4S250 PR222MP In200	80-200	1600	A185	185
110	193	T5S400 PR222MP In320	128-320	1920	A210	210
132	232	T5S400 PR222MP In320	128-320	2240	A260	260
160	282	T5S400 PR222MP In320	128-320	2560	AF400**	320
200	349	T5S400 PR222MP In400	160-400	3200	AF400	400
250	430	T6S800 PR222MP In630	252-630	5040	AF460	460
290	520	T6S800 PR222MP In630	252-630	5670	AF580	580
315	545	T6S800 PR222MP In630	252-630	5670	AF580	580
355	610	T6S800 PR222MP In630	252-630	5670	AF750	630

(\*) for heavy-duty start set the electronic release tripping class to class 30  
 (\*\*) in case of normal start use AF300

TSDC010023F0201

### 3 Protection of electrical equipment

Table 7: 440 V 50 kA DOL Normal Type 2  
(Tmax – Contactor – TOR)

Motor		MCCB		Contactor	Thermal Overload Release		
P <sub>e</sub> [kW]	I <sub>r</sub> [A]	Type	I <sub>3</sub> [A]	Type	Type	Current setting	
						min. [A]	max. [A]
0.37	1	T2H160 MF 1	13	A9	TA25DU1.4	1	1.4
0.55	1.4	T2H160 MF 1.6	21	A9	TA25DU1.8	1.3	1.8
0.75	1.7	T2H160 MF 2	26	A9	TA25DU2.4	1.7	2.4
1.1	2.2	T2H160 MF 2.5	33	A9	TA25DU3.1	2.2	3.1
1.5	3	T2H160 MF 3.2	42	A16	TA25DU4	2.8	4
2.2	4.4	T2H160 MF 5	65	A26	TA25DU5	3.5	5
3	5.7	T2H160 MF 6.5	84	A26	TA25DU6.5	4.5	6.5
4	7.8	T2H160 MF 8.5	110	A30	TA25DU11	7.5	11
5.5	10.5	T2H160 MF 11	145	A30	TA25DU14	10	14
7.5	13.5	T2H160 MA 20	180	A30	TA25DU19	13	19
11	19	T2H160 MA 32	240	A30	TA42DU25	18	25
15	26	T2H160 MA 32	336	A50	TA75DU32	22	32
18.5	32	T2H160 MA 52	469	A50	TA75DU42	29	42
22	38	T2H160 MA 52	547	A50	TA75DU52	36	52
30	52	T2H160 MA 80	720	A63	TA75DU63	45	63
37	63	T2H160 MA 80	840	A75	TA75DU80	60	80
45	75	T2H160 MA 100	1050	A95	TA110DU90	65	90
55	90	T4H250 PR221-I In160	1200	A110	TA110DU110	80	110
75	120	T4H250 PR221-I In250	1750	A145	E200DU200	60	200
90	147	T4H250 PR221-I In250	2000	A185	E200DU200	60	200
110	177	T4H250 PR221-I In250	2500	A210	E320DU320	100	320
132	212	T5H400 PR221-I In320	3200	A260	E320DU320	100	320
160	260	T5H400 PR221-I In400	3600	A300	E320DU320	100	320
200	320	T5H630 PR221-I In630	4410	AF 400	E500DU500	150	500
250	410	T6H630 PR221-I In630	5355	AF 460	E500DU500	150	500
290	448	T6H630 PR221-I In630	6300	AF 580	E500DU500*	150	500
315	500	T6H800 PR221-I In800	7200	AF 580	E800DU800	250	800
355	549	T6H800 PR221-I In800	8000	AF 580	E800DU800	250	800

\* Connection kit not available. To use the connection kit, replace with relay E800DU800.  
MA: magnetic only adjustable release  
MF: fixed magnetic only release

1SDC010024F0201

### 3 Protection of electrical equipment

Table 8: 440 V 50 kA DOL Heavy duty Type 2  
(Tmax – Contactor – TOR)

Motor		MCCB		Contactor	Thermal Overload Release			
P <sub>e</sub> [kW]	I <sub>r</sub> [A]	Type	I <sub>3</sub> [A]	Type	Type**	No. of turns of the CT primary coil	Current setting	
							min. [A]	max. [A]
0.37	1	T2H160 MF 1	13	A9	TA25DU1.4*		1	1.4
0.55	1.4	T2H160 MF 1.6	21	A9	TA25DU1.8*		1.3	1.8
0.75	1.7	T2H160 MF 2	26	A9	TA25DU2.4*		1.7	2.4
1.1	2.2	T2H160 MF 2.5	33	A9	TA25DU3.1*		2.2	3.1
1.5	3	T2H160 MF 3.2	42	A16	TA25DU4*		2.8	4
2.2	4.4	T2H160 MF 5	65	A26	TA25DU5*		3.5	5
3	5.7	T2H160 MF 6.5	84	A26	TA25DU6.5*		4.5	6.5
4	7.8	T2H160 MF 8.5	110	A30	TA25DU11*		7.5	11
5.5	10.5	T2H160 MF 11	145	A30	TA25DU14*		10	14
7.5	13.5	T2H160 MA 20	180	A30	TA450SU60	4	10	15
11	19	T2H160 MA 32	240	A30	TA450SU80	3	18	27
15	26	T2H160 MA 32	336	A50	TA450SU60	2	20	30
18.5	32	T2H160 MA 52	469	A50	TA450SU80	2	28	40
22	38	T2H160 MA 52	547	A50	TA450SU80	2	28	40
30	52	T2H160 MA 80	720	A63	TA450SU60		40	60
37	63	T2H160 MA 80	840	A95	TA450SU80		55	80
45	75	T2H160 MA 100	1050	A110	TA450SU105		70	105
55	90	T4H250 PR221-I In160	1200	A145	E200DU200		60	200
75	120	T4H250 PR221-I In250	1750	A185	E200DU200		60	200
90	147	T4H250 PR221-I In250	2000	A210	E320DU320		100	320
110	177	T4H250 PR221-I In250	2500	A260	E320DU320		100	320
132	212	T5H400 PR221-I In320	3200	A300	E320DU320		100	320
160	260	T5H400 PR221-I In400	3600	AF400	E500DU500		150	500
200	320	T5H630 PR221-I In630	4410	AF460	E500DU500		150	500
250	410	T6H630 PR221-I In630	5355	AF580	E500DU500***		150	500
290	448	T6H630 PR221-I In630	6300	AF750	E500DU500***		150	500
315	500	T6H800 PR221-I In800	7200	AF 750	E800DU800		250	800
355	549	T6H800 PR221-I In800	8000	AF 750	E800DU800		250	800

\* Provide a by-pass contactor of the same size during motor start-up

\*\* For type E releases choose tripping class 30

\*\*\* Connecting kit not available. To use the connecting kit, replacement with release E800DU800 is necessary

MA: magnetic only adjustable release

MF: fixed magnetic only release

1SDC010024F0201

### 3 Protection of electrical equipment

**Table 9: 440 V 50 kA Y/Δ Normal Type 2  
(Tmax – Contactor – TOR)**

Motor		MCCB		Contactor			Thermal Overload Release	
P <sub>e</sub> [kW]	I <sub>r</sub> [A]	Type	I <sub>3</sub> [A]	LINE Type	DELTA Type	STAR Type	Type	Current setting
18.5	32	T2H160 MA52	392	A 50	A 50	A 16	TA75DU25	18-25
22	38	T2H160 MA52	469	A 50	A 50	A 26	TA75DU25	18-25
30	52	T2H160 MA80	720	A 63	A 63	A 26	TA75DU42	29-42
37	63	T2H160 MA80	840	A 75	A 75	A 30	TA75DU42	29-42
45	75	T2H160 MA80	960	A 75	A 75	A30	TA75DU52	36-52
55	90	T2H160 MA100	1150	A 75	A 75	A40	TA75DU63	45 - 63
75	120	T4H250 PR221-I In250	1625	A95	A95	A75	TA80DU80	60-80
90	147	T4H250 PR221-I In250	1875	A95	A95	A75	TA110DU110	80-110
110	177	T4H250 PR221-I In250	2250	A145	A145	A95	E200DU200	60-200
132	212	T4H320 PR221-I In320	2720	A145	A145	A110	E200DU200	60-200
160	260	T5H400 PR221-I In400	3200	A185	A185	A145	E200DU200	60-200
200	320	T5H630 PR221-I In630	4095	A210	A210	A185	E320DU320	100-320
250	410	T5H630 PR221-I In630	5040	A260	A260	A210	E320DU320	100-320
290	448	T6H630 PR221-I In630	5670	AF400	AF400	A260	E500DU500	150 - 500
315	500	T6H630 PR221-I In630	6300	AF400	AF400	A260	E500DU500	150 - 500
355	549	T6H800 PR221-I In800	7200	AF400	AF400	A260	E500DU500	150 - 500

MA : Magnetic only adjustable release

**Table 10: 440 V 50 kA DOL Normal and Heavy duty Type 2  
(Tmax with MP release-Contactor)**

Motor		MCCB			Contactor	Group
P <sub>e</sub> [kW]	I <sub>r</sub> [A]	Type	I <sub>1</sub> * range [A]	I <sub>3</sub> [A]	Type	[A]
30	52	T4H250 PR222MP In100	40-100	600	A95	93
37	63	T4H250 PR222MP In100	40-100	700	A95	93
45	75	T4H250 PR222MP In100	40-100	800	A95	93
55	90	T4H250 PR222MP In160	64-160	960	A145	145
75	120	T4H250 PR222MP In160	64-160	1120	A145	145
90	147	T4H250 PR222MP In200	80-200	1400	A185	185
110	177	T5H400 PR222MP In320	128-320	1920	A210	210
132	212	T5H400 PR222MP In320	128-320	2240	A260	240
160	260	T5H400 PR222MP In320	128-320	2560	AF400**	320
200	320	T5H400 PR222MP In400	160-400	3200	AF400	400
250	370	T6H800 PR222MP In630	252-630	4410	AF460	460
290	436	T6H800 PR222MP In630	252-630	5040	AF460	460
315	500	T6H800 PR222MP In630	252-630	5040	AF580	580
355	549	T6H800 PR222MP In630	252-630	5670	AF580	580

(\*) for heavy-duty start set the electronic release tripping class to class 30

(\*\*) in case of normal start use AF300

1SDCO10025F0201

### 3 Protection of electrical equipment

**Table 11: 500 V 50 kA DOL Normal Type 2  
(Tmax – Contactor – TOR)**

Motor		MCCB		Contactor	Thermal Overload Release		
P <sub>e</sub> [kW]	I <sub>r</sub> [A]	Type	I <sub>3</sub> [A]	Type	Type	Current setting	
						min. [A]	max. [A]
0.37	0.88	T2L160 MF 1	13	A9	TA25DU1.0	0.63	1
0.55	1.2	T2L160 MF 1.6	21	A9	TA25DU1.4	1	1.4
0.75	1.5	T2L160 MF 1.6	21	A9	TA25DU1.8	1.3	1.8
1.1	2.2	T2L160 MF 2.5	33	A9	TA25DU3.1	2.2	3.1
1.5	2.8	T2L160 MF 3.2	42	A16	TA25DU4	2.8	4
2.2	4	T2L160 MF 4	52	A26	TA25DU5	3.5	5
3	5.2	T2L160 MF 6.5	84	A26	TA25DU6.5	4.5	6.5
4	6.9	T2L160 MF 8.5	110	A30	TA25DU8.5	6	8.5
5.5	9.1	T2L160 MF 11	145	A30	TA25DU11	7.5	11
7.5	12.2	T2L160 MF 12.5	163	A30	TA25DU14	10	14
11	17.5	T2L160 MA 20	240	A30	TA25DU19	13	19
15	23	T2L160 MA 32	336	A50	TA75DU25	18	25
18.5	29	T2L160 MA 52	392	A50	TA75DU32	22	32
22	34	T2L160 MA 52	469	A50	TA75DU42	29	42
30	45	T2L160 MA 52	624	A63	TA75DU52	36	52
37	56	T2L160 MA 80	840	A75	TA75DU63	45	63
45	67	T2L160 MA 80	960	A95	TA80DU80	60	80
55	82	T2L160 MA 100	1200	A110	TA110DU90	65	90
75	110	T4H250 PR221-I In160	1440	A145	E200DU200	60	200
90	132	T4H250 PR221-I In250	1875	A145	E200DU200	60	200
110	158	T4H250 PR221-I In250	2250	A185	E200DU200	60	200
132	192	T4H320 PR221-I In320	2720	A210	E320DU320	100	320
160	230	T5H400 PR221-I In400	3600	A260	E320DU320	100	320
200	279	T5H400 PR221-I In400	4000	A300	E320DU320	100	320
250	335	T5H630 PR221-I In630	4725	AF 400	E 500DU500	150	500
290	394	T6L630 PR221-I In630	5040	AF 460	E 500DU500	150	500
315	440	T6L630 PR221-I In630	6300	AF 580	E 500DU500*	150	500
355	483	T6L630 PR221-I In630	6300	AF 580	E 800DU800	250	800

\* Connection kit not available. To use the connection kit, replace with relay E800DU800.

MA: magnetic only adjustable release

MF: fixed magnetic only release

1SDCO10026F0201

### 3 Protection of electrical equipment

**Table 12: 500 V 50 kA DOL Heavy duty Type 2 (Tmax – Contactor – TOR)**

Motor		MCCB		Contactor	Thermal Overload Release			
P <sub>e</sub> [kW]	I <sub>r</sub> [A]	Type	I <sub>3</sub> [A]	Type	Type**	No. of turns of the CT primary coil	Current setting min.   max.	
							[A]	[A]
0.37	0.88	T2L160 MF 1	13	A9	TA25DU1.0*		0.63	1
0.55	1.2	T2L160 MF 1.6	21	A9	TA25DU1.4*		1	1.4
0.75	1.5	T2L160 MF 1.6	21	A9	TA25DU1.8*		1.3	1.8
1.1	2.2	T2L160 MF 2.5	33	A9	TA25DU3.1*		2.2	3.1
1.5	2.8	T2L160 MF 3.2	42	A16	TA25DU4*		2.8	4
2.2	4	T2L160 MF 4	52	A26	TA25DU5*		3.5	5
3	5.2	T2L160 MF 6.5	84	A26	TA25DU6.5*		4.5	6.5
4	6.9	T2L160 MF 8.5	110	A30	TA25DU8.5*		6	8.5
5.5	9.1	T2L160 MF 11	145	A30	TA25DU11*		7.5	11
7.5	12.2	T2L160 MF 12.5	163	A30	TA450SU60	4	10	15
11	17.5	T2L160 MA 20	240	A30	TA450SU60	3	13	20
15	23	T2L160 MA 32	336	A50	TA450SU60	2	20	30
18.5	29	T2L160 MA 52	392	A50	TA450SU80	2	27.5	40
22	34	T2L160 MA 52	469	A50	TA450SU80	2	27.5	40
30	45	T2L160 MA 52	624	A63	TA450SU60		40	60
37	56	T2L160 MA 80	840	A75	TA450SU60		40	60
45	67	T2L160 MA 80	960	A95	TA450SU80		55	80
55	82	T2L160 MA 100	1200	A145	TA450SU105		70	105
75	110	T4H250 PR221-I In160	1440	A145	E200DU200		60	200
90	132	T4H250 PR221-I In250	1875	A185	E200DU200		60	200
110	158	T4H250 PR221-I In250	2123	A210	E320DU320		100	320
132	192	T4H320 PR221-I In320	2720	A260	E320DU320		100	320
160	230	T5H400 PR221-I In400	3200	A300	E320DU320		100	320
200	279	T5H400 PR221-I In400	3600	AF400	E500DU500		150	500
250	335	T5H630 PR221-I In630	4725	AF460	E500DU500		150	500
290	394	T6L630 PR221-I In630	5040	AF580	E500DU500***		150	500
315	440	T6L630 PR221-I In630	6300	AF750	E500DU500***		150	500
355	483	T6L630 PR221-I In630	6300	AF750	E500DU500		150	500

\* Provide a by-pass contactor of the same size during motor start-up  
 \*\* For type E releases choose tripping class 30  
 \*\*\* Connecting kit not available. To use the connecting kit, replacement with release E800DU800 is necessary  
 MA: magnetic only adjustable release  
 MF: fixed magnetic only release

1SDC010021F0201

### 3 Protection of electrical equipment

**Table 13: 500 V 50 kA Y/Δ Normal Type 2 (Tmax – Contactor – TOR)**

Motor		MCCB		Contactor			Thermal Overload Release	
P <sub>e</sub> [kW]	I <sub>r</sub> [A]	Type	I <sub>3</sub> [A]	LINE Type	DELTA Type	STAR Type	Type	Current setting
22	34	T2L160 MA52	430	A 50	A 50	A 16	TA75DU25	18-25
30	45	T2L160 MA52	547	A 63	A 63	A 26	TA75DU32	22-32
37	56	T2L160 MA80	720	A 75	A 75	A 30	TA75DU42	29-42
45	67	T2L160 MA80	840	A 75	A 75	A 30	TA75DU52	36 - 52
55	82	T2L160 MA100	1050	A 75	A 75	A 30	TA75DU52	36 - 52
75	110	T4H250 PR221-I In250	1375	A95	A95	A50	TA80DU80	60-80
90	132	T4H250 PR221-I In250	1750	A95	A95	A75	TA110DU90	65-90
110	158	T4H250 PR221-I In250	2000	A110	A110	A95	TA110DU110	80-110
132	192	T4H320 PR221-I In320	2560	A145	A145	A95	E200DU200	60-200
160	230	T4H320 PR221-I In320	2880	A145	A145	A110	E200DU200	60-200
200	279	T5H400 PR221-I In400	3400	A210	A210	A145	E320DU320	100-320
250	335	T5H630 PR221-I In630	4410	A210	A210	A185	E320DU320	100-320
290	394	T5H630 PR221-I In630	5040	A260	A260	A210	E320DU320	100-320
315	440	T6L630 PR221-I In630	5760	AF400	AF400	A210	E500DU500	150 - 500
355	483	T6L630 PR221-I In630	6300	AF400	AF400	A260	E500DU500	150 - 500

MA: magnetic only adjustable release

**Table 14: 500 V 50 kA DOL Normal and Heavy duty Type 2 (Tmax with MP release-Contactor)**

Motor		MCCB			Contactor	Group
P <sub>e</sub> [kW]	I <sub>r</sub> [A]	Type	I <sub>1</sub> * range [A]	I <sub>3</sub> [A]	Type	[A]
30	45	T4H250 PR222MP In100	40-100	600	A95	80
37	56	T4H250 PR222MP In100	40-100	600	A95	80
45	67	T4H250 PR222MP In100	40-100	700	A145	100
55	82	T4H250 PR222MP In100	40-100	800	A145	100
75	110	T4H250 PR222MP In160	64-160	1120	A145	145
90	132	T4H250 PR222MP In160	64-160	1280	A145	145
110	158	T4H250 PR222MP In200	80-200	1600	A185	170
132	192	T5H400 PR222MP In320	128-320	1920	A210	210
160	230	T5H400 PR222MP In320	128-320	2240	A260	260
200	279	T5H400 PR222MP In400	160-400	2800	AF400**	400
250	335	T5H400 PR222MP In400	160-400	3200	AF400	400
290	395	T6H800 PR222MP In630	252-630	5040	AF460	460
315	415	T6H800 PR222MP In630	252-630	5040	AF460	460
355	451	T6H800 PR222MP In630	252-630	5670	AF580	580

(\*) for heavy duty start set the electronic release tripping class to class 30  
 (\*\*) in case of normal start use AF300

1SDC010021F0201

### 3 Protection of electrical equipment

Table 15: 690 V 50kA DOL Normal Type 2  
(Tmax-Contactor-CT-TOR)

Motor		MCCB		Contactor	CT		Thermal overload Relay		
P <sub>e</sub> [kW]	I <sub>e</sub> [A]	Type	I <sub>3</sub> [A]	Type	KORC	N° of primary turns	Type	current setting min. [A]	max. [A]
0.37	0.6	T2L160 MF1	13	A9			TA25DU0.63	0.4	0.63
0.55	0.9	T2L160 MF1	13	A9			TA25DU1	0.63	1
0.75	1.1	T2L160 MF1.6	21	A9			TA25DU1.4	1	1.4
1.1	1.6	T2L160 MF1.6	21	A9			TA25DU1.8	1.3	1.8
1.5	2	T2L160 MF2.5	33	A9			TA25DU2.4	1.7	2.4
2.2	2.9	T2L160 MF3.2	42	A9			TA25DU3.1*	2.2	3.1
3	3.8	T2L160 MF4	52	A9			TA25DU4*	2.8	4
4	5	T2L160 MF5	65	A9			TA25DU5*	3.5	5
5.5	6.5	T2L160 MF6.5	84	A9			TA25DU6.5*	4.5	6.5
		T4L250 PR221-I In 100	150	A95	4L185R/4	13**	TA25DU2.4	6	8.5
7.5	8.8	T4L250 PR221-I In 100	150	A95	4L185R/4	10**	TA25DU2.4	7.9	11.1
11	13	T4L250 PR221-I In 100	200	A95	4L185R/4	7**	TA25DU2.4	11.2	15.9
15	18	T4L250 PR221-I In 100	250	A95	4L185R/4	7**	TA25DU3.1	15.2	20.5
18.5	21	T4L250 PR221-I In 100	300	A95	4L185R/4	6	TA25DU3.1	17.7	23.9
22	25	T4L250 PR221-I In 100	350	A95	4L185R/4	6	TA25DU4	21.6	30.8
30	33	T4L250 PR221-I In 100	450	A145	4L185R/4	6	TA25DU5	27	38.5
37	41	T4L250 PR221-I In 100	550	A145	4L185R/4	4	TA25DU4	32.4	46.3
45	49	T4L250 PR221-I In 100	700	A145	4L185R/4	4	TA25DU5	40.5	57.8
55	60	T4L250 PR221-I In 100	800	A145	4L185R/4	3	TA25DU5	54	77.1
75	80	T4L250 PR221-I In 160	1120	A145			E200DU200	65	200
90	95	T4L250 PR221-I In 160	1280	A145			E200DU200	65	200
110	115	T4L250 PR221-I In 250	1625	A145			E200DU200	65	200
132	139	T4L250 PR221-I In 250	2000	A185			E200DU200	65	200
160	167	T4L250 PR221-I In 250	2250	A185			E200DU200	65	200
200	202	T5L400 PR221-I In 320	2720	A210			E320DU320	105	320
250	242	T5L400 PR221-I In 400	3400	A300			E320DU320	105	320
290	301	T5L630 PR221-I In 630	4410	AF400			E500DU500	150	500
315	313	T5L630 PR221-I In 630	4410	AF400			E500DU500	150	500
355	370	T5L630 PR221-I In 630	5355	AF580			E500DU500***	150	500

1SDC010108F0201

For further information about the KORC, please see the "brochure KORC 1GB00-04" catalogue.

(\*) Type 1 coordination

(\*\*) Cable cross section equal to 4 mm<sup>2</sup>

(\*\*\*) No mounting kit to contactor is available; to use mounting kit provide E800DU800

### 3 Protection of electrical equipment

Table 16: 690 V 50 kA DOL Heavy duty Type 2  
(Tmax – Contactor – TOR)

Motor		MCCB		Contactor	Thermal overload Relay			
P <sub>e</sub> [kW]	I <sub>r</sub> [A]	Type	I <sub>3</sub> [A]	Type	Type	N° of primary turns	Current setting min. [A]	max. [A]
0.37	0.6	T2L160 MF1	13	A9	TA25DU0.63(X)		0.4	0.63
0.55	0.9	T2L160 MF1	13	A9	TA25DU1(X)		0.63	1
0.75	1.1	T2L160 MF1.6	21	A9	TA25DU1.4(X)		1	1.4
1.1	1.6	T2L160 MF1.6	21	A9	TA25DU1.8(X)		1.3	1.8
1.5	2	T2L160 MF2.5	33	A9	TA25DU2.4(X)		1.7	2.4
2.2	2.9	T2L160 MF3.2	42	A9	TA25DU3.1*(X)		2.2	3.1
3	3.8	T2L160 MF4	52	A9	TA25DU4*(X)		2.8	4
4	5	T2L160 MF5	65	A9	TA25DU5*(X)		3.5	5
5.5	6.5	T2L160 MF6.5	84	A9	TA25DU6.5*(X)		4.5	6.5
		T4L250 PR221-I In 100	150	A95	TA450SU60	7**	5.7	8.6
7.5	8.8	T4L250 PR221-I In 100	150	A95	TA450SU60	5**	8	12
11	13	T4L250 PR221-I In 100	200	A95	TA450SU60	4**	10	15
15	18	T4L250 PR221-I In 100	250	A95	TA450SU60	3**	13	20
18.5	21	T4L250 PR221-I In 100	300	A95	TA450SU80	3	18	27
22	25	T4L250 PR221-I In 100	350	A95	TA450SU60	2	20	30
30	33	T4L250 PR221-I In 100	450	A145	TA450SU80	2	27.5	40
37	41	T4L250 PR221-I In 100	550	A145	TA450SU60		40	60
45	49	T4L250 PR221-I In 100	700	A145	TA450SU60		40	60
55	60	T4L250 PR221-I In 100	800	A145	TA450SU80		55	80
75	80	T4L250 PR221-I In 160	1120	A145	TA450SU105		70	105
90	95	T4L250 PR221-I In 160	1280	A145	TA450SU105		70	105
110	115	T4L250 PR221-I In 250	1625	A185	TA450SU140		95	140
132	139	T4L250 PR221-I In 250	2000	A210	E320DU320		105	320
160	167	T4L250 PR221-I In 250	2250	A210	E320DU320		105	320
200	202	T5L400 PR221-I In 320	2720	A260	E320DU320		105	320
250	242	T5L400 PR221-I In 400	3400	AF400	E500DU500		150	500
290	301	T5L630 PR221-I In 630	4410	AF400	E500DU500		150	500
315	313	T5L630 PR221-I In 630	4410	AF460	E500DU500		150	500
355	370	T5L630 PR221-I In 630	5355	AF580	E500DU500***		150	500

1SDC010109F0201

(\*) Type 1 coordination

(\*\*) Cable cross section equal to 4 mm<sup>2</sup>

(\*\*\*) No mounting kit to contactor is available; to use mounting kit provide E800DU800

(X) Provide by-pass contactor during motor start-up

### 3 Protection of electrical equipment

**Table 17: 690 V 50 kA Y/Δ Normal Type 2  
(Tmax – Contactor – CT – TOR)**

Motor		MCCB			Contactor			CT		Overload Release	
P <sub>e</sub> [kW]	I <sub>r</sub> [A]	Type	I <sub>3</sub> [A]	Line Type	Delta Type	Star Type	KORC	N° of primary turns	Type	Current setting [A]	
5.5	6.5*	T4L250PR221-I In100	150	A95	A95	A26	4L185R/4**	13	TA25DU2.4**	6-8.5	
7.5	8.8*	T4L250PR221-I In100	150	A95	A95	A26	4L185R/4**	10	TA25DU2.4**	7.9-11.1	
11	13*	T4L250PR221-I In100	200	A95	A95	A26	4L185R/4**	7	TA25DU2.4**	11.2-15.9	
15	18*	T4L250PR221-I In100	250	A95	A95	A26	4L185R/4**	7	TA25DU3.1**	15.2-20.5	
18.5	21	T4L250PR221-I In100	300	A95	A95	A30	4L185R/4**	6	TA25DU3.1**	17.7-23.9	
22	25	T4L250PR221-I In100	350	A95	A95	A30	4L185R/4**	6	TA25DU4**	21.6-30.8	
30	33	T4L250PR221-I In100	450	A145	A145	A30	4L185R/4**	6	TA25DU5**	27-38.5	
37	41	T4L250PR221-I In100	550	A145	A145	A30			TA75DU52**	36-52	
45	49	T4L250PR221-I In100	650	A145	A145	A30			TA75DU52**	36-52	
55	60	T4L250PR221-I In100	800	A145	A145	A40			TA75DU52**	36-52	
75	80	T4L250PR221-I In160	1120	A145	A145	A50			TA75DU52	36-52	
90	95	T4L250PR221-I In160	1280	A145	A145	A75			TA75DU63	45-63	
110	115	T4L250PR221-I In160	1600	A145	A145	A75			TA75DU80	60-80	
132	139	T4L250PR221-I In250	1875	A145	A145	A95			TA200DU110	80-110	
160	167	T4L250PR221-I In250	2125	A145	A145	A110			TA200DU110	80-110	
200	202	T4L320PR221-I In320	2720	A185	A185	A110			TA200DU135	100-135	
250	242	T5L400PR221-I In400	3200	AF400	AF400	A145			E500DU500	150-500	
290	301	T5L400PR221-I In400	4000	AF400	AF400	A145			E500DU500	150-500	
315	313	T5L630PR221-I In630	4410	AF400	AF400	A185			E500DU500	150-500	
355	370	T5L630PR221-I In630	5040	AF400	AF400	A210			E500DU500	150-500	
400	420	T5L630PR221-I In630	5670	AF460	AF460	A210			E500DU500	150-500	
450	470	T5L630PR221-I In630	6300	AF460	AF460	A260			E500DU500	150-500	

1SDC010110F0201

For further information about the KORC, please see the "brochure KORC 1GB00-04" catalogue.

(\*) Cable cross section equal to 4 mm<sup>2</sup>

(\*\*) Connect the overload/relay upstream the line-delta node

### 3 Protection of electrical equipment

**Table 18: 690 V 50 kA DOL Normal and Heavy duty Type 2  
(Tmax with MP release-Contactor)**

Motor		MCCB			Contactor	Group
P <sub>e</sub> [kW]	I <sub>r</sub> [A]	Type	I <sub>1</sub> * range [A]	I <sub>3</sub> [A]	Type	[A]
45	49	T4L250 PR222MP In100	40-100	600	A145	100
55	60	T4L250 PR222MP In100	40-100	600	A145	100
75	80	T4L250 PR222MP In100	40-100	800	A145	100
90	95	T4L250 PR222MP In160	64-160	960	A145	120
110	115	T4L250 PR222MP In160	64-160	1120	A145	120
132	139	T4L250 PR222MP In160	64-160	1440	A185	160
160	167	T4L250 PR222MP In200	80-200	1600	A185	170
200	202	T5L400 PR222MP In320	128-320	1920	A210	210
250	242	T5L400 PR222MP In320	128-320	2240	A300	280
290	301	T5L400 PR222MP In400	160-400	2800	AF400	350
315	313	T5L400 PR222MP In400	160-400	3200	AF400	350

1SDC010114F0201

(\*) for heavy duty start set the electronic release tripping class to class 30



### 3 Protection of electrical equipment

#### Example:

For a Y/Δ Normal starting Type 2, of a three phase asynchronous squirrel-cage motor with the following data:

rated voltage  $U_r = 400$  V

short-circuit current  $I_k = 50$  kA

rated motor power  $P_e = 200$  kW

from Table 5, on the relevant row, the following information can be found:

- $I_r$  (rated current): 349 A;
- short-circuit protection device: circuit-breaker T5S630 PR221-I In630;
- magnetic trip threshold:  $I_3 = 4410$  A;
- line contactor: A210;
- delta contactor: A210;
- star contactor: A185;
- thermal release E320DU320, setting range 100+320 A (to be set at  $\frac{I_r}{\sqrt{3}} = 202$  A).

For a DOL heavy-duty starting Type 2 with MP protection of a three phase asynchronous squirrel-cage motor with the following data:

rated voltage  $U_r = 400$  V

short-circuit current  $I_k = 50$  kA

rated motor power  $P_e = 55$  kW

from Table 6, on the relevant row, the following information can be found:

- $I_r$  (rated current): 98 A;
- short-circuit protection device: circuit breaker T4S250 PR222MP\* In160;
- magnetic trip threshold:  $I_3 = 960$  A;
- contactor: A145;

\* for heavy-duty start set the electronic release tripping class to class 30

### 3 Protection of electrical equipment

#### 3.4 Protection and switching of transformers

##### General aspects

Transformers are used to achieve a change in the supply voltage, for both medium and low voltage supplies.

The choice of the protection devices must take into account transient insertion phenomena, during which the current may reach values higher than the rated full load current; the phenomenon decays in a few seconds.

The curve which represents these transient phenomena in the time-current diagram, termed "inrush current  $I_0$ ", depends on the size of the transformer and can be evaluated with the following formula (the short-circuit power of the network is assumed to be equal to infinity)

$$I_0 = \frac{K \cdot I_{1r} \cdot e^{(-t/\tau)}}{\sqrt{2}}$$

where:

$K$  ratio between the maximum peak inrush current value ( $I_0$ ) and the rated current of the transformer ( $I_{1r}$ ): ( $K = I_0 / I_{1r}$ );

$\tau$  time constant of the inrush current;

$I_{1r}$  rated current of the primary;

$t$  time.

The table below shows the indicative values for  $t$  and  $K$  parameters referred to rated power  $S_r$  for oil transformers.

$S_r$ [kVA]	50	100	160	250	400	630	1000	1600	2000
$K = I_0 / I_{1r}$	15	14	12	12	12	11	10	9	8
$\tau$ [s]	0.10	0.15	0.20	0.22	0.25	0.30	0.35	0.40	0.45

Further to the above consideration, the following diagram shows the inrush current curve for a 20/0.4kV of 400kVA transformer. This transformer has an inrush current during the very first moments equal to about 8 times the rated current; this transient phenomenon stops after a few tenths of a second.

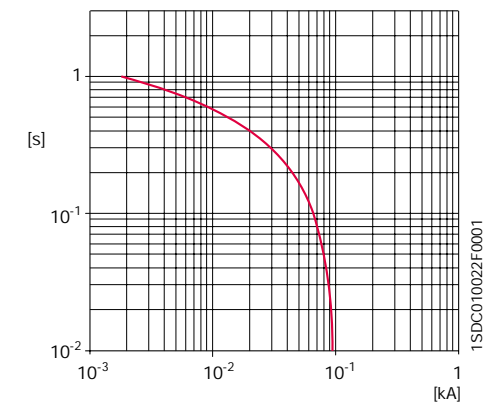



### 3 Protection of electrical equipment

The transformer protection devices must also guarantee that the transformer cannot operate above the point of maximum thermal overload under short-circuit conditions; this point is defined on the time-current diagram by the value of short-circuit current which can pass through the transformer and by a time equal to 2 s, as stated by Standard IEC 60076-5. The short-circuit current ( $I_k$ ) flowing for a fault with low impedance at the LV terminals of the transformer is calculated by using the following formula:

$$I_k = \frac{U_r}{\sqrt{3} \cdot (Z_{Net} + Z_t)} \quad [A] \quad (1)$$

where:

- $U_r$  is the rated voltage of the transformer [V];
- $Z_{Net}$  is the short-circuit impedance of the network [ $\Omega$ ];
- $Z_t$  is the short-circuit impedance of the transformer; from the rated power of the transformer ( $S_r$  [VA]) and the percentage short-circuit voltage ( $u_k\%$ ) it is equal to:

$$Z_t = \frac{u_k \% \cdot U_r^2}{100 \cdot S_r} \quad [\Omega] \quad (2)$$

Considering the upstream short-circuit power of the network to be infinite ( $Z_{Net}=0$ ), formula (1) becomes:

$$I_k = \frac{U_r}{\sqrt{3} \cdot (Z_t)} = \frac{U_r}{\sqrt{3} \cdot \left( \frac{u_k \% \cdot U_r^2}{100 \cdot S_r} \right)} = \frac{100 \cdot S_r}{\sqrt{3} \cdot u_k \% \cdot U_r} \quad [A] \quad (3)$$

The diagram below shows the inrush current curve for a 20/0.4 kV of 400 kVA transformer ( $u_k\% = 4\%$ ) and the point referred to the thermal ability to withstand the short-circuit current ( $I_k$ ; 2 sec.).

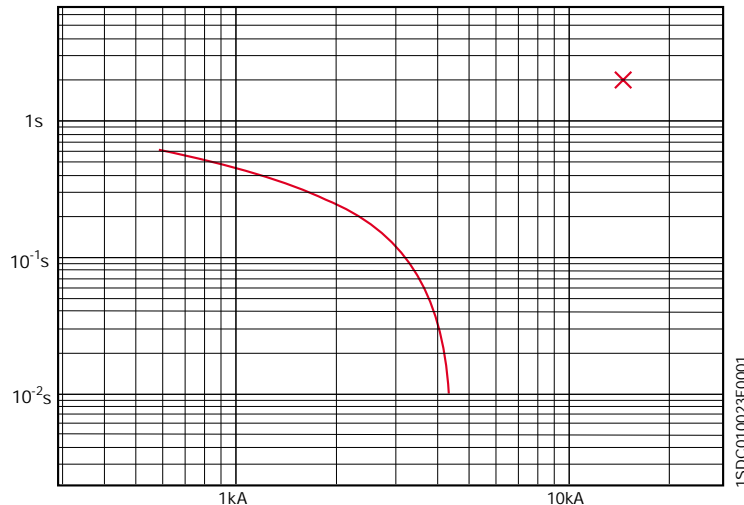

### 3 Protection of electrical equipment

In summary: for the correct protection of the transformer and to avoid unwanted trips, the trip curve of the protection device must be above the inrush current curve and below the overload point.

The diagram below shows a possible position of the time-current curve of an upstream protection device of a 690/400 V, 250 kVA transformer with  $u_k\% = 4\%$ .

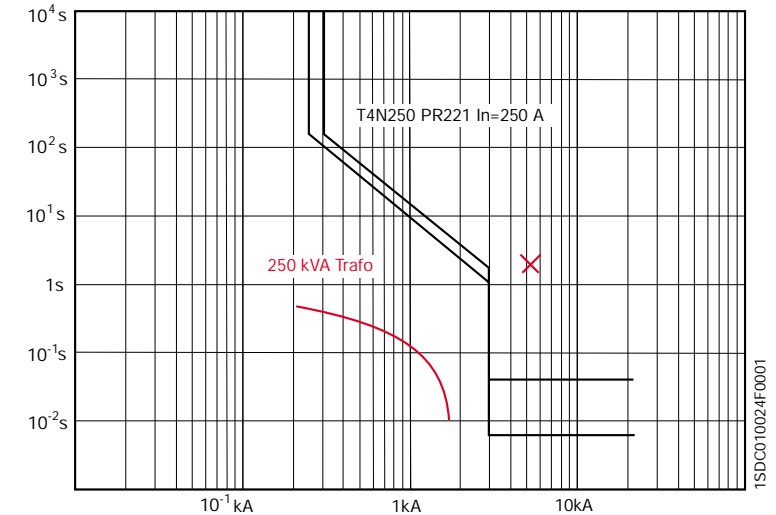

#### Criteria for the selection of protection devices

For the protection at the LV side of MV/LV transformers, the selection of a circuit-breaker shall take into account:

- the rated current at LV side of the protected transformer (this value is the reference value for the rated current of the circuit-breaker and the setting of the protections);
- the maximum short-circuit current at the point of installation (this value determines the minimum breaking capacity ( $I_{cu}/I_{cs}$ ) of the protection device).

#### MV/LV unit with single transformer

The rated current at the LV side of the transformer ( $I_r$ ) is determined by the following formula:

$$I_r = \frac{1000 \cdot S_r}{\sqrt{3} \cdot U_{r20}} \quad [A] \quad (4)$$

where:

- $S_r$  is the rated power of the transformer [kVA];
- $U_{r20}$  is the rated LV no-load voltage of the transformer [V].

### 3 Protection of electrical equipment

The full voltage three-phase short-circuit current ( $I_k$ ), at the LV terminals of the transformer, can be expressed as (assuming that the short-circuit power of the network is infinite):

$$I_k = \frac{100 \cdot I_r}{u_k \%} \text{ [A]} \quad (5)$$

where:

$u_k\%$  is the short-circuit voltage of the transformer, in %.

The protection circuit-breaker must have: (\*)

$$I_n \geq I_r;$$

$$I_{cu} (I_{cs}) \geq I_k.$$

If the short-circuit power of the upstream network is not infinite and cable or busbar connections are present, it is possible to obtain a more precise value for  $I_k$  by using formula (1), where  $Z_{Net}$  is the sum of the impedance of the network and of the impedance of the connection.

*MV/LV substation with more than one transformer in parallel*

For the calculation of the rated current of the transformer, the above applies (formula 4).

The breaking capacity of each protection circuit-breaker on the LV side shall be higher than the short-circuit current equivalent to the short-circuit current of each equal transformer multiplied by the number of them minus one.

As can be seen from the diagram below, in the case of a fault downstream of a transformer circuit-breaker (circuit-breaker A), the short-circuit current that flows through the circuit-breaker is equal to the contribution of a single transformer. In the case of a fault upstream of the same circuit-breaker, the short-circuit current that flows is equal to the contribution of the other two transformers in parallel.

(\*) To carry out correct protection against overload it is advisable to use thermometric equipment or other protection devices able to monitor temperature inside transformers.

### 3 Protection of electrical equipment

For a correct dimensioning, a circuit-breaker with a breaking capacity higher than twice the short-circuit current of one of the transformers must be chosen (assuming that all the transformers are equal and the loads are passive).

The circuit-breakers positioned on the outgoing feeders (circuit-breakers B) shall have a breaking capacity higher than the sum of the short-circuit currents of the three transformers, according to the hypothesis that the upstream network short-circuit power is 750 MVA and the loads are passive.

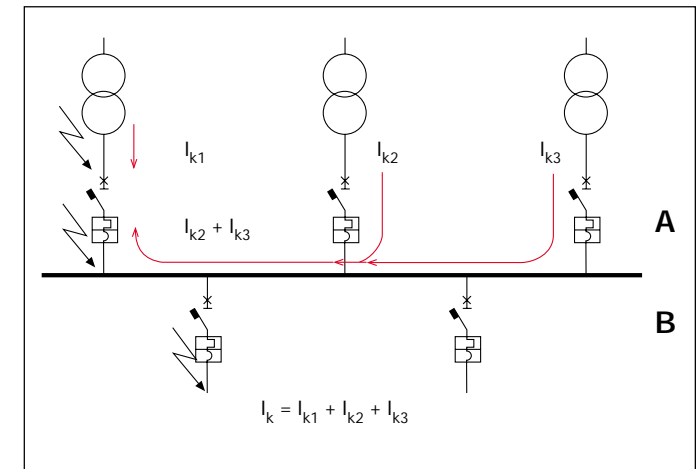

1SDC010025F0001

### 3 Protection of electrical equipment

#### Selection of the circuit-breaker

The following tables show some possible choices of ABB SACE circuit-breakers, according to the characteristics of the transformer to be protected.

Table 1: Protection and switching of 230 V transformers

Transformer		Circuit-breaker "A" (LV side)						
$S_r$	$u_k$	Trafo $I_r$	Busbar $I_b$	Trafo feeder $I_k$	ABB SACE Circuit-breaker	Release		Busbar $I_k$
[kVA]	[%]	[A]	[A]	[kA]		size	minimum setting	[kA]
1 x 63	4	158	158	3.9	T1B160*	In=160	1	3.9
2 x 63		158	316	3.9	T1B160*	In=160	1	7.9
1 x 100	4	251	251	6.3	T4N320	In=320	0.79	6.3
2 x 100		251	502	6.2	T4N320	In=320	0.79	12.5
1 x 125	4	314	314	7.8	T5N400	In=400	0.79	7.8
2 x 125		314	628	7.8	T5N400	In=400	0.79	15.6
1 x 160	4	402	402	10.0	T5N630	In=630	0.64	10.0
2 x 160		402	803	9.9	T5N630	In=630	0.64	19.9
1 x 200	4	502	502	12.5	T5N630	In=630	0.8	12.5
2 x 200		502	1004	12.4	T5N630	In=630	0.8	24.8
1 x 250	4	628	628	15.6	T5N630	In=630	1	15.6
2 x 250		628	1255	15.4	T5N630	In=630	1	30.9
1 x 315	4	791	791	19.6	T6N800	In=800	1	19.6
2 x 315		791	1581	19.4	T6N800	In=800	1	38.7
1 x 400	4	1004	1004	24.8	T7S1250/X1B1250**	In=1250	0.81	24.8
2 x 400		1004	2008	24.5	T7S1250/X1B1250**	In=1250	0.81	48.9
1 x 500	4	1255	1255	30.9	T7S1600/X1B1600**	In=1600	0.79	30.9
2 x 500		1255	2510	30.4	T7S1600/X1B1600**	In=1600	0.79	60.7
1 x 630	4	1581	1581	38.7	T7S1600/X1B1600**	In=1600	1	38.7
2 x 630		1581	3163	37.9	T7S1600/X1B1600**	In=1600	1	75.9
3 x 630	5	1581	4744	74.4	T7S1600/E2S1600	In=1600	1	111.6
1 x 800		2008	2008	39.3	E3N2500	In=2500	0.81	39.3
2 x 800	5	2008	4016	38.5	E3N2500	In=2500	0.81	77.0
3 x 800		2008	6025	75.5	E3H2500	In=2500	0.81	113.2
1 x 1000	5	2510	2510	48.9	E3N3200	In=3200	0.79	48.9
2 x 1000		2510	5020	47.7	E3N3200	In=3200	0.79	95.3
3 x 1000	5	2510	7531	93.0	E3H3200	In=3200	0.79	139.5
1 x 1250		3138	3138	60.7	E3N3200	In=3200	1	60.7
2 x 1250	5	3138	6276	58.8	E3N3200	In=3200	1	117.7
3 x 1250		3138	9413	114.1	E4V3200	In=3200	1	171.2

\* also Tmax series CBs equipped with electronic releases can be used for this application

\*\* also Isomax CB type S7 and Emax type E1 can be used for this application

### 3 Protection of electrical equipment

Circuit-breaker "B" (Feeder circuit-breaker)								
Feeder circuit-breaker type and rated current								
630 A	800 A	1000 A	1250 A	1600 A	2000 A	2500 A	3200 A	4000 A
T5N630								
T5N630								
T5N630	T6N800/X1B800							
T5N630								
T5N630	T6N800/X1B800	T7S1000/X1B1000	T7S1250/X1B1250					
T5N630	T6N800/X1B800							
T5N630	T6N800/X1N800	T7S1000/X1N1000	T7S1250/X1N1250	T7S1600/X1N1600				
T5N630	T6N800/X1B800							
T5N630	T6N800/X1N800	T7S1000/X1N1000	T7S1250/X1N1250	T7S1600/X1N1600	E2N2000			
T5N630	T6N800/X1B800	T7S1000/X1B1000	T7S1250/X1B1250					
T5S630	T6S800/E2S800	T7S1000/E2S1000	T7S1250/E2S1250	T7S1600/E2S1600	E2S2000	E3H2500		
T5L630	T6L800/E3V800	T7L1000/E3V1250	T7L1250/E3V1250	T7L1600/E3V1600	E3V2000	E3V2500	E3V3200	
T5N630	T6N800/X1B800	T7S1000/X1B1000	T7S1250/X1B1250	T7S1600/X1B1600				
T5S630	T6L800/E2S800	T7S1000/E2S1000	T7S1250/E2S1250	T7S1600/E2S1600	E2S2000	E3H2500	E3H3200	
T5L630	T6L800/E3V800	T7L1000/E3V1250	T7L1250/E3V1250	T7L1600/E3V1600	E3V2000	E3V2500	E4V3200	E4V4000
T5N630	T6N800/X1N800	T7S1000/X1N1000	T7S1250/X1N1250	T7S1600/X1N1600	E2N2000			
T5H630	T6H800/E3H800	T7H1000/E3H1000	T7H1250/E3H1250	T7H1600/E3H1600	E3H2000	E3H2500	E3H3200	E4H4000
T5L630	T6L800	T7L1000	T7L1250	T7L1600	E4V3200	E4V3200	E4V3200	E4V4000
T5N630	T6N800/X1N800	T7S1000/X1N1000	T7S1250/X1N1250	T7S1600/X1N1600	E2N2000	E3N2500		
T5L630	T6L800/E3V800	T7L1000/E3V1250	T7L1250/E3V1250	T7L1600/E3V1600	E3V2000	E3V2500	E3V3200	E4V4000
T5L630	T6L800	T7L1000	T7L1250	T7L1600				

TSDC0100395F0201







### 3 Protection of electrical equipment

#### NOTE

The tables refer to the previously specified conditions; the information for the selection of circuit-breakers is supplied only with regard to the current in use and the prospective short-circuit current. For a correct selection, other factors such as selectivity, back-up protection, the decision to use limiting circuit-breakers etc. must also be considered. Therefore, it is essential that the design engineers carry out precise checks.

It must also be noted that the short-circuit currents given are determined using the hypothesis of 750 MVA power upstream of the transformers, disregarding the impedances of the busbars or the connections to the circuit-breakers.

#### Example:

Supposing the need to size breakers A1/A2/A3, on the LV side of the three transformers of 630 kVA 20/0.4 kV with  $u_k\%$  equal to 4% and outgoing feeder circuit-breakers B1/B2/B3 of 63-400-800 A:

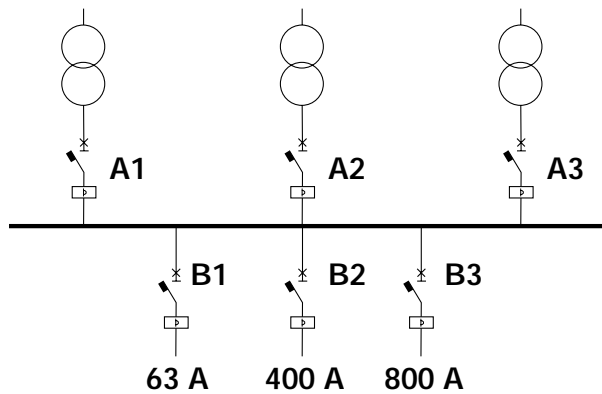

1SDC010026F0001

### 3 Protection of electrical equipment

From Table 2, corresponding to the row relevant to 3x630 kVA transformers, it can be read that:

#### Level A circuit-breakers (LV side of transformer)

- Trafo  $I_r$  (909 A) is the current that flows through the transformer circuit-breakers;
- Busbar  $I_b$  (2727 A) is the maximum current that the transformers can supply;
- Trafo Feeder  $I_k$  (42.8 kA) is the value of the short-circuit current to consider for the choice of the breaking capacity of each of the transformer circuit-breakers;
- T7S1000 or X1N1000 is the size of the transformer circuit-breaker;
- $I_n$  (1000 A) is the rated current of the transformer circuit-breaker (electronic release chosen by the user);
- The minimum value 0.91 indicate the minimum settings of the L function of the electronic releases for CBs T7S1000 and X1N1000.

#### Level B circuit-breakers (outgoing feeder)

- Busbar  $I_k$  (64.2 kA) is the short-circuit current due to the contribution of all three transformers;
- corresponding to 63 A, read circuit-breaker B1 Tmax T2H160;
- corresponding to 400 A, read circuit-breaker B2 Tmax T5H400;
- corresponding to 800 A, read circuit-breaker B3 Tmax T6H800 or Emax X1N800.

The choice made does not take into account discrimination/back-up requirements. Refer to the relevant chapters for selections appropriate to the various cases.

## 4 Power factor correction

### 4.1 General aspects

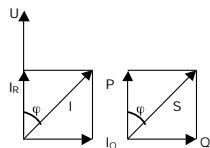

In alternating current circuits, the current absorbed by the user can be represented by two components:

- the active component  $I_R$ , in phase with the supply voltage, is directly correlated to the output (and therefore to the part of electrical energy transformed into energy of a different type, usually electrical with different characteristics, mechanical, light and/or thermal);
- the reactive component  $I_Q$ , in quadrature to the voltage, is used to produce the flow necessary for the conversion of powers through the electric or magnetic field. Without this, there could be no flow of power, such as in the core of a transformer or in the air gap of a motor.

In the most common case, in the presence of ohmic-inductive type loads, the total current ( $I$ ) lags in comparison with the active component  $I_R$ .

In an electrical installation, it is necessary to generate and transmit, other than the active power  $P$ , a certain reactive power  $Q$ , which is essential for the conversion of electrical energy, but not available to the user. The complex of the power generated and transmitted constitutes the apparent power  $S$ .

Power factor ( $\cos\varphi$ ) is defined as the ratio between the active component  $I_R$  and the total value of the current  $I$ ;  $\varphi$  is the phase shifting between the voltage  $U$  and the current  $I$ .

It results:

$$\cos\varphi = \frac{I_R}{I} = \frac{P}{S} \quad (1)$$

The reactive demand factor ( $\tan\varphi$ ) is the relationship between the reactive power and the active power:

$$\tan\varphi = \frac{Q}{P} \quad (2)$$

## 4 Power factor correction

Table 1 shows some typical power factors:

**Table 1: Typical power factor**

Load	$\cos\varphi$ power factor	$\tan\varphi$ reactive demand factor
Transformers (no load condition)	0.1÷0.15	9.9÷6.6
Motor (full load)	0.7÷0.85	1.0÷0.62
Motor (no load)	0.15	6.6
Metal working apparatuses:		
- Arc welding	0.35÷0.6	2.7÷1.3
- Arc welding compensated	0.7÷0.8	1.0÷0.75
- Resistance welding:	0.4÷0.6	2.3÷1.3
- Arc melting furnace	0.75÷0.9	0.9÷0.5
Fluorescent lamps		
- compensated	0.9	0.5
- uncompensated	0.4÷0.6	2.3÷1.3
Mercury vapour lamps	0.5	1.7
Sodium vapour lamp	0.65÷0.75	1.2÷0.9
AC DC converters	0.6÷0.95	1.3÷0.3
DC drives	0.4÷0.75	2.3÷0.9
AC drives	0.95÷0.97	0.33÷0.25
Resistive load	1	0

The power factor correction is the action increasing the power factor in a specific section of the installation by locally supplying the necessary reactive power, so as to reduce the current value to the equivalent of the power required, and therefore the total power absorbed from the upstream side. Thus, both the line as well as the supply generator can be sized for a lower apparent power value required by the load.

In detail, as shown by Figure 1 and Figure 2, increasing the power factor of the load:

- decreases the relative voltage drop  $u_{r,p}$  per unit of active power transmitted;
- increases the transmittable active power and decreases the losses, the other dimensioning parameters remaining equal.



## 4 Power factor correction

Figure 1: Relative voltage drop

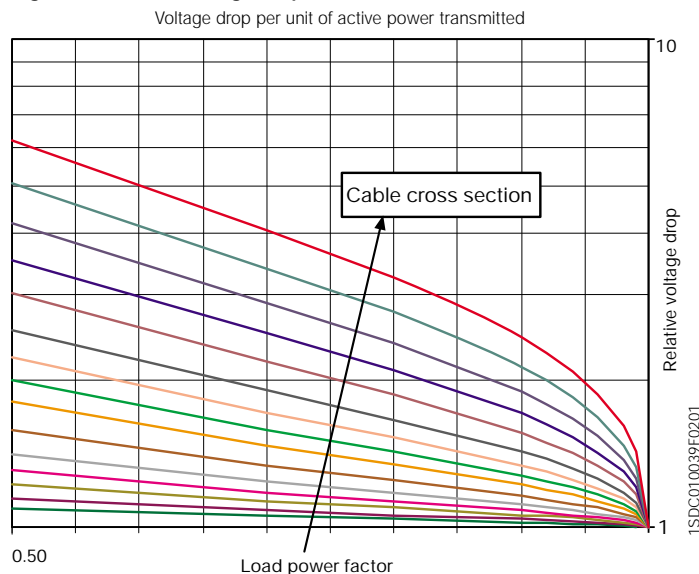
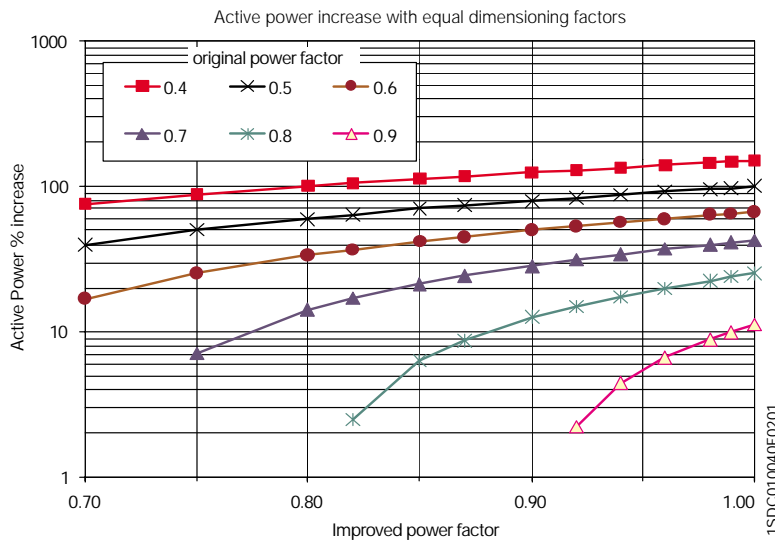

Figure 2: Transmittable active power



## 4 Power factor correction

The distribution authority is responsible for the production and transmission of the reactive power required by the user installations, and therefore has a series of further inconveniences which can be summarized as:

- oversizing of the conductors and of the components of the transmission lines;
- higher Joule-effect losses and higher voltage drops in the components and lines.

The same inconveniences are present in the distribution installation of the final user. The power factor is an excellent index of the size of the added costs and is therefore used by the distribution authority to define the purchase price of the energy for the final user.

The ideal situation would be to have a  $\cos\phi$  slightly higher than the set reference so as to avoid payment of legal penalties, and at the same time not to risk having, with a  $\cos\phi$  too close to the unit, a leading power factor when the power factor corrected device is working with a low load.

The distribution authority generally does not allow others to supply reactive power to the network, also due to the possibility of unexpected overvoltages.

In the case of a sinusoidal waveform, the reactive power necessary to pass from one power factor  $\cos\phi_1$  to a power factor  $\cos\phi_2$  is given by the formula:

$$Q_c = Q_2 - Q_1 = P \cdot (\tan\phi_1 - \tan\phi_2) \quad (3)$$

where:

$P$  is the active power;

$Q_1, \phi_1$  are the reactive power and the phase shifting before power factor correction;

$Q_2, \phi_2$  are the reactive power and the phase shifting after power factor correction;

$Q_c$  is the reactive power for the power factor correction.

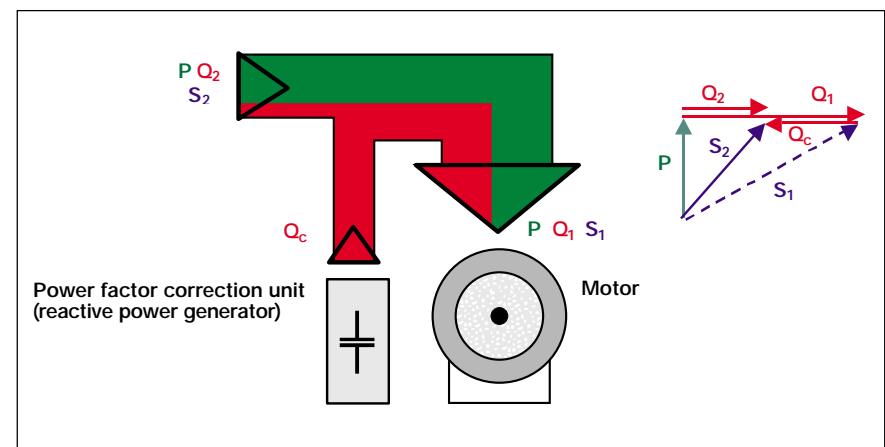

## 4 Power factor correction

Table 2 shows the value of the relationship

$$K_c = \frac{Q_c}{P} = \tan\varphi_1 - \tan\varphi_2 \quad (4)$$

for different values of the power factor before and after the correction.

**Table 2: Factor  $K_c$**

$K_c$	$\cos\varphi_2$													
$\cos\varphi_1$	0.80	0.85	0.90	0.91	0.92	0.93	0.94	0.95	0.96	0.97	0.98	0.99	1	
0.60	0.583	0.714	0.849	0.878	0.907	0.938	0.970	1.005	1.042	1.083	1.130	1.191	1.333	
0.61	0.549	0.679	0.815	0.843	0.873	0.904	0.936	0.970	1.007	1.048	1.096	1.157	1.299	
0.62	0.515	0.646	0.781	0.810	0.839	0.870	0.903	0.937	0.974	1.015	1.062	1.123	1.265	
0.63	0.483	0.613	0.748	0.777	0.807	0.837	0.870	0.904	0.941	0.982	1.030	1.090	1.233	
0.64	0.451	0.581	0.716	0.745	0.775	0.805	0.838	0.872	0.909	0.950	0.998	1.058	1.201	
0.65	0.419	0.549	0.685	0.714	0.743	0.774	0.806	0.840	0.877	0.919	0.966	1.027	1.169	
0.66	0.388	0.519	0.654	0.683	0.712	0.743	0.775	0.810	0.847	0.888	0.935	0.996	1.138	
0.67	0.358	0.488	0.624	0.652	0.682	0.713	0.745	0.779	0.816	0.857	0.905	0.966	1.108	
0.68	0.328	0.459	0.594	0.623	0.652	0.683	0.715	0.750	0.787	0.828	0.875	0.936	1.078	
0.69	0.299	0.429	0.565	0.593	0.623	0.654	0.686	0.720	0.757	0.798	0.846	0.907	1.049	
0.70	0.270	0.400	0.536	0.565	0.594	0.625	0.657	0.692	0.729	0.770	0.817	0.878	1.020	
0.71	0.242	0.372	0.508	0.536	0.566	0.597	0.629	0.663	0.700	0.741	0.789	0.849	0.992	
0.72	0.214	0.344	0.480	0.508	0.538	0.569	0.601	0.635	0.672	0.713	0.761	0.821	0.964	
0.73	0.186	0.316	0.452	0.481	0.510	0.541	0.573	0.608	0.645	0.686	0.733	0.794	0.936	
0.74	0.159	0.289	0.425	0.453	0.483	0.514	0.546	0.580	0.617	0.658	0.706	0.766	0.909	
0.75	0.132	0.262	0.398	0.426	0.456	0.487	0.519	0.553	0.590	0.631	0.679	0.739	0.882	
0.76	0.105	0.235	0.371	0.400	0.429	0.460	0.492	0.526	0.563	0.605	0.652	0.713	0.855	
0.77	0.079	0.209	0.344	0.373	0.403	0.433	0.466	0.500	0.537	0.578	0.626	0.686	0.829	
0.78	0.052	0.183	0.318	0.347	0.376	0.407	0.439	0.474	0.511	0.552	0.599	0.660	0.802	
0.79	0.026	0.156	0.292	0.320	0.350	0.381	0.413	0.447	0.484	0.525	0.573	0.634	0.776	
0.80		0.130	0.266	0.294	0.324	0.355	0.387	0.421	0.458	0.499	0.547	0.608	0.750	
0.81		0.104	0.240	0.268	0.298	0.329	0.361	0.395	0.432	0.473	0.521	0.581	0.724	
0.82		0.078	0.214	0.242	0.272	0.303	0.335	0.369	0.406	0.447	0.495	0.556	0.698	
0.83		0.052	0.188	0.216	0.246	0.277	0.309	0.343	0.380	0.421	0.469	0.530	0.672	
0.84		0.026	0.162	0.190	0.220	0.251	0.283	0.317	0.354	0.395	0.443	0.503	0.646	
0.85			0.135	0.164	0.194	0.225	0.257	0.291	0.328	0.369	0.417	0.477	0.620	
0.86			0.109	0.138	0.167	0.198	0.230	0.265	0.302	0.343	0.390	0.451	0.593	
0.87			0.082	0.111	0.141	0.172	0.204	0.238	0.275	0.316	0.364	0.424	0.567	
0.88			0.055	0.084	0.114	0.145	0.177	0.211	0.248	0.289	0.337	0.397	0.540	
0.89			0.028	0.057	0.086	0.117	0.149	0.184	0.221	0.262	0.309	0.370	0.512	
0.90				0.029	0.058	0.089	0.121	0.156	0.193	0.234	0.281	0.342	0.484	

## 4 Power factor correction

### Example

Supposing the need to change from 0.8 to 0.93 the power factor of a three-phase installation ( $U_r = 400 \text{ V}$ ) which absorbs an average power of 300 kW. From Table 2, at the intersection of the column corresponding to the final power factor (0.93), and the row corresponding to the starting power factor (0.8), the value of  $K_c$  (0.355) can be read. The reactive power  $Q_c$  which must be generated locally shall be:

$$Q_c = K_c \cdot P = 0.355 \cdot 300 = 106.5 \text{ Kvar}$$

Due to the effect of power factor correction, the current absorbed decreases from 540 A to 460 A (a reduction of approximately 15%).

### Characteristics of power factor correction capacitor banks

The most economical means of increasing the power factor, especially for an installation which already exists, is installing capacitors.

Capacitors have the following advantages:

- low cost compared with synchronous compensators and electronic power converters;
- ease of installation and maintenance;
- reduced losses (less than 0.5 W/kvar in low voltage);
- the possibility of covering a wide range of powers and different load profiles, simply supplying in parallel different combinations of components, each with a relatively small power.

The disadvantages are sensitivity to overvoltages and to the presence of non-linear loads.

The Standards applicable to power factor correction capacitors are as follows:

- IEC 60831-1 "Shunt power capacitors of the self-healing type for a.c. systems having a rated voltage up to and including 1000 V - Part 1: General - Performance, testing and rating - Safety requirements - Guide for installation and operation";
- IEC 60931-1 "Shunt power capacitors of the non-self-healing type for a.c. systems having a rated voltage up to and including 1000 V - Part 1: General - Performance, testing and rating - Safety requirements - Guide for installation and operation".

## 4 Power factor correction

The characteristics of a capacitor, given on its nameplate, are:

- rated voltage  $U_r$ , which the capacitor must withstand indefinitely;
- rated frequency  $f_r$  (usually equal to that of the network);
- rated power  $Q_c$ , generally expressed in kvar (reactive power of the capacitor bank).

From this data it is possible to find the size characteristics of the capacitors by using the following formulae (5):

	Single-phase connection	Three-phase star-connection	Three-phase delta-connection
Capacity of the capacitor bank	$C = \frac{Q_c}{2\pi f_r \cdot U_r^2}$	$C = \frac{Q_c}{2\pi f_r \cdot U_r^2}$	$C = \frac{Q_c}{2\pi f_r \cdot U_r^2 \cdot 3}$
Rated current of the components	$I_{rc} = 2\pi f_r \cdot C \cdot U_r$	$I_{rc} = 2\pi f_r \cdot C \cdot U_r / \sqrt{3}$	$I_{rc} = 2\pi f_r \cdot C \cdot U_r$
Line current	$I_l = I_{rc}$	$I_l = I_{rc}$	$I_l = I_{rc} \cdot \sqrt{3}$

$U_r$  = line voltage system

In a three-phase system, to supply the same reactive power, the star connection requires a capacitor with a capacitance three times higher than the delta-connected capacitor.

In addition, the capacitor with the star connection results to be subjected to a voltage  $\sqrt{3}$  lower and flows through by a current  $\sqrt{3}$  higher than a capacitor inserted and delta connected.

Capacitors are generally supplied with connected discharge resistance, calculated so as to reduce the residual voltage at the terminals to 75 V in 3 minutes, as stated in the reference Standard.

## 4.2 Power factor correction method

### Single PFC

Single or individual power factor correction is carried out by connecting a capacitor of the correct value directly to the terminals of the device which absorbs reactive power.

Installation is simple and economical: capacitors and load can use the same overload and short-circuit protection, and are connected and disconnected simultaneously.

The adjustment of  $\cos\phi$  is systematic and automatic with benefit not only to the energy distribution authority, but also to the whole internal distribution system of the user.

This type of power factor correction is advisable in the case of large users with constant load and power factor and long connection times.

Individual PFC is usually applied to motors and fluorescent lamps. The capacitor units or small lighting capacitors are connected directly to loads.

## 4 Power factor correction

### Individual PFC of motors

The usual connection diagrams are shown in the following figure:

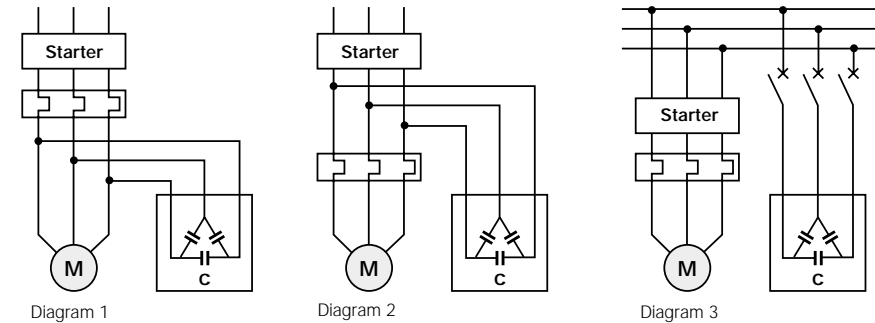

In the case of direct connection (diagrams 1 and 2) there is a risk that after disconnection of the supply, the motor will continue to rotate (residual kinetic energy) and self-excite with the reactive energy supplied by the capacitor bank, acting as an asynchronous generator. In this case, the voltage is maintained on the load side of the switching and control device, with the risk of dangerous overvoltages of up to twice the rated voltage value.

However, in the case of diagram 3, to avoid the risk detailed above, the normal procedure is to connect the PFC bank to the motor only when it is running, and to disconnect it before the disconnection of the motor supply.

As a general rule, for a motor with power  $P_r$ , it is advisable to use a PFC with reactive power  $Q_c$  below 90% of the reactive power absorbed by the no-load motor  $Q_0$ , at rated voltage  $U_r$ , to avoid a leading power factor.

Considering that under no-load conditions, the current absorbed  $I_0$  [A] is solely reactive, if the voltage is expressed in volts, it results:

$$Q_c = 0.9 \cdot Q_0 = 0.9 \cdot \frac{\sqrt{3} \cdot U_r \cdot I_0}{1000} \text{ [kvar]} \quad (6)$$

The current  $I_0$  is generally given in the documentation supplied by the manufacturer of the motor.

## 4 Power factor correction

Table 3 shows the values of reactive power for power factor correction of some ABB motors, according to the power and the number of poles.

Table 3: Reactive power for power factor motor correction

P <sub>r</sub> [kW]	Q <sub>c</sub> [kvar]	Before PFC		After PFC	
		cosφ <sub>r</sub>	I <sub>r</sub> [A]	cosφ <sub>2</sub>	I <sub>2</sub> [A]
<b>400V / 50 Hz / 2 poles / 3000 r/min</b>					
7.5	2.5	0.89	13.9	0.98	12.7
11	2.5	0.88	20	0.95	18.6
15	5	0.9	26.5	0.98	24.2
18.5	5	0.91	32	0.98	29.7
22	5	0.89	38.5	0.96	35.8
30	10	0.88	53	0.97	47.9
37	10	0.89	64	0.97	58.8
45	12.5	0.88	79	0.96	72.2
55	15	0.89	95	0.97	87.3
75	15	0.88	131	0.94	122.2
90	15	0.9	152	0.95	143.9
110	20	0.86	194	0.92	181.0
132	30	0.88	228	0.95	210.9
160	30	0.89	269	0.95	252.2
200	30	0.9	334	0.95	317.5
250	40	0.92	410	0.96	391.0
315	50	0.92	510	0.96	486.3
<b>400V / 50 Hz / 4 poles / 1500 r/min</b>					
7.5	2.5	0.86	14.2	0.96	12.7
11	5	0.81	21.5	0.96	18.2
15	5	0.84	28.5	0.95	25.3
18.5	7.5	0.84	35	0.96	30.5
22	10	0.83	41	0.97	35.1
30	15	0.83	56	0.98	47.5
37	15	0.84	68	0.97	59.1
45	20	0.83	83	0.97	71.1
55	20	0.86	98	0.97	86.9
75	20	0.86	135	0.95	122.8
90	20	0.87	158	0.94	145.9
110	30	0.87	192	0.96	174.8
132	40	0.87	232	0.96	209.6
160	40	0.86	282	0.94	257.4
200	50	0.86	351	0.94	320.2
250	50	0.87	430	0.94	399.4
315	60	0.87	545	0.93	507.9

## 4 Power factor correction

P <sub>r</sub> [kW]	Q <sub>c</sub> [kvar]	Before PFC		After PFC	
		cosφ <sub>r</sub>	I <sub>r</sub> [A]	cosφ <sub>2</sub>	I <sub>2</sub> [A]
<b>400V / 50 Hz / 6 poles / 1000 r/min</b>					
7.5	5	0.79	15.4	0.98	12.4
11	5	0.78	23	0.93	19.3
15	7.5	0.78	31	0.94	25.7
18.5	7.5	0.81	36	0.94	30.9
22	10	0.81	43	0.96	36.5
30	10	0.83	56	0.94	49.4
37	12.5	0.83	69	0.94	60.8
45	15	0.84	82	0.95	72.6
55	20	0.84	101	0.96	88.7
75	25	0.82	141	0.93	123.9
90	30	0.84	163	0.95	144.2
110	35	0.83	202	0.94	178.8
132	45	0.83	240	0.95	210.8
160	50	0.85	280	0.95	249.6
200	60	0.85	355	0.95	318.0
250	70	0.84	450	0.94	404.2
315	75	0.84	565	0.92	514.4
<b>400V / 50 Hz / 8 poles / 750 r/min</b>					
7.5	5	0.7	18.1	0.91	13.9
11	7.5	0.76	23.5	0.97	18.4
15	7.5	0.82	29	0.97	24.5
18.5	7.5	0.79	37	0.93	31.5
22	10	0.77	45	0.92	37.5
30	12.5	0.79	59	0.93	50.0
37	15	0.78	74	0.92	62.8
45	20	0.78	90	0.93	75.4
55	20	0.81	104	0.93	90.2
75	30	0.82	140	0.95	120.6
90	30	0.82	167	0.93	146.6
110	35	0.83	202	0.94	178.8
132	50	0.8	250	0.93	214.6

## 4 Power factor correction

### Example

For a three-phase asynchronous motor, 110 kW (400 V - 50 Hz - 4 poles), the PFC power suggested in the table is 30 kvar.

### Individual power factor correction of three-phase transformers

A transformer is an electrical device of primary importance which, due to the system requirements, is often constantly in service.

In particular, in installations constituted by several transformer substations, it is advisable to carry out power factor correction directly at the transformer.

In general, the PFC power ( $Q_c$ ) for a transformer with rated power  $S_r$  [kVA] should not exceed the reactive power required under minimum reference load conditions.

Reading the data from the transformer nameplate, the percentage value of the no-load current  $i_0\%$ , the percentage value of the short-circuit voltage  $u_k\%$ , the iron losses  $P_{fe}$  and the copper losses  $P_{cu}$  [kW], the PFC power required is approximately:

$$Q_c = \sqrt{\left(\frac{i_0\%}{100} \cdot S_r\right)^2 - P_{fe}^2} + K_L^2 \cdot \sqrt{\left(\frac{u_k\%}{100} \cdot S_r\right)^2 - P_{cu}^2} \approx \left(\frac{i_0\%}{100} \cdot S_r\right) + K_L^2 \cdot \left(\frac{u_k\%}{100} \cdot S_r\right) \quad [\text{kvar}] \quad (7)$$

where  $K_L$  is the load factor, defined as the relationship between the minimum reference load and the rated power of the transformer.

### Example

Supposing the need for PFC of a 630 kVA oil-distribution transformer which supplies a load which is less than 60% of its rated power.

From the data on the transformer nameplate:

$$i_0\% = 1.8\%$$

$$u_k\% = 4\%$$

$$P_{cu} = 8.9 \text{ kW}$$

$$P_{fe} = 1.2 \text{ kW}$$

The PFC power of the capacitor bank connected to the transformer is:

$$Q_c = \sqrt{\left(\frac{i_0\%}{100} \cdot S_r\right)^2 - P_{fe}^2} + K_L^2 \cdot \sqrt{\left(\frac{u_k\%}{100} \cdot S_r\right)^2 - P_{cu}^2} = \sqrt{\left(\frac{1.8\%}{100} \cdot 630\right)^2 - 1.2^2} + 0.6^2 \cdot \sqrt{\left(\frac{4\%}{100} \cdot 630\right)^2 - 8.9^2} = 19.8 \text{ kvar}$$

while, when using the simplified formula, the result is:

$$Q_c = \left(\frac{i_0\%}{100} \cdot S_r\right) + K_L^2 \cdot \left(\frac{u_k\%}{100} \cdot S_r\right) = \left(\frac{1.8\%}{100} \cdot 630\right) + 0.6^2 \cdot \left(\frac{4\%}{100} \cdot 630\right) = 20.4 \text{ kvar}$$

## 4 Power factor correction

Table 4 shows the reactive power of the capacitor bank  $Q_c$  [kvar] to be connected on the secondary side of an ABB transformer, according to the different minimum estimated load levels.

Table 4: PFC reactive power for ABB transformers

$S_r$ [kVA]	$u_k\%$ [%]	$i_0\%$ [%]	$P_{fe}$ [kW]	$Q_c$ [kvar]		load factor $K_L$				
				$P_{cu}$ [kW]		0	0.25	0.5	0.75	1
<b>Oil Distribution Transformer MV-LV</b>										
50	4	2.9	0.25	1.35	1.4	1.5	1.8	2.3	2.9	
100	4	2.5	0.35	2.30	2.5	2.7	3.3	4.3	5.7	
160	4	2.3	0.48	3.20	3.6	4	5	6.8	9.2	
200	4	2.2	0.55	3.80	4.4	4.8	6.1	8.3	11	
250	4	2.1	0.61	4.50	5.2	5.8	7.4	10	14	
315	4	2	0.72	5.40	6.3	7	9.1	13	18	
400	4	1.9	0.85	6.50	7.6	8.5	11	16	22	
500	4	1.9	1.00	7.40	9.4	11	14	20	28	
630	4	1.8	1.20	8.90	11	13	17	25	35	
800	6	1.7	1.45	10.60	14	16	25	40	60	
1000	6	1.6	1.75	13.00	16	20	31	49	74	
1250	6	1.6	2.10	16.00	20	24	38	61	93	
1600	6	1.5	2.80	18.00	24	30	47	77	118	
2000	6	1.2	3.20	21.50	24	31	53	90	142	
2500	6	1.1	3.70	24.00	27	37	64	111	175	
3150	7	1.1	4.00	33.00	34	48	89	157	252	
4000	7	1.4	4.80	38.00	56	73	125	212	333	

<b>Cast Resin Distribution Transformer MV-LV</b>										
100	6	2.3	0.50	1.70	2.2	2.6	3.7	5.5	8	
160	6	2	0.65	2.40	3.1	3.7	5.5	8.4	12	
200	6	1.9	0.85	2.90	3.7	4.4	6.6	10	15	
250	6	1.8	0.95	3.30	4.4	5.3	8.1	13	19	
315	6	1.7	1.05	4.20	5.3	6.4	9.9	16	24	
400	6	1.5	1.20	4.80	5.9	7.3	12	19	29	
500	6	1.4	1.45	5.80	6.8	8.7	14	23	36	
630	6	1.3	1.60	7.00	8	10	17	29	45	
800	6	1.1	1.94	8.20	8.6	12	20	35	56	
1000	6	1	2.25	9.80	9.7	13	25	43	69	
1250	6	0.9	3.30	13.00	11	15	29	52	85	
1600	6	0.9	4.00	14.50	14	20	38	67	109	
2000	6	0.8	4.60	15.50	15	23	45	82	134	
2500	6	0.7	5.20	17.50	17	26	54	101	166	
3150	8	0.6	6.00	19.00	18	34	81	159	269	

### Example

For a 630 kVA oil-distribution transformer with a load factor of 0.5, the necessary PFC power is 17 kvar.

## 4 Power factor correction

### PFC in groups

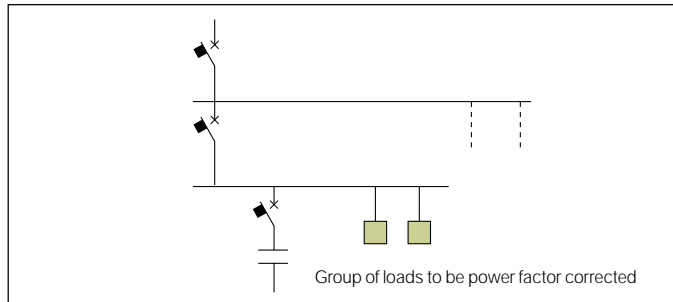

This consists of local power factor correction of groups of loads with similar functioning characteristics by installing a dedicated capacitor bank. This method achieves a compromise between the economical solution and the correct operation of the installation, since only the line downstream of the installation point of the capacitor bank is not correctly exploited.

### Centralized PFC

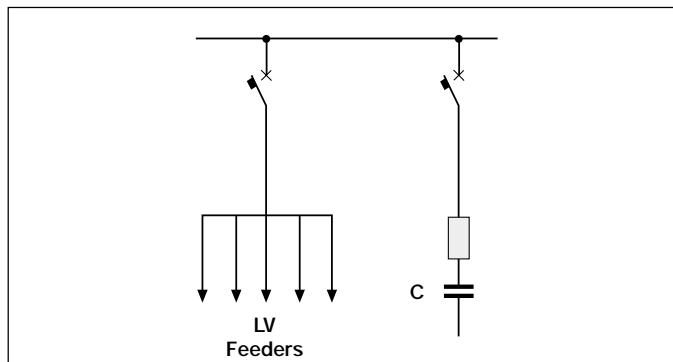

The daily load profile is of fundamental importance for the choice of the most suitable type of power factor correction. In installations, in which not all loads function simultaneously and/or in which some loads are connected for only a few hours a day, the solution of using single PFC becomes unsuitable as many of the capacitors installed could stay idle for long periods. In the case of installations with many loads occasionally functioning, thus having a high installed power and a quite low average power absorption by the loads which function simultaneously, the use of a single PFC system at the installation origin ensures a remarkable decrease in the total power of the capacitors to be installed.

## 4 Power factor correction

Centralized PFC normally uses automatic units with capacitor banks divided into several steps, directly installed in the main distribution switchboards; the use of a permanently connected capacitor bank is only possible if the absorption of reactive energy is fairly regular throughout the day. The main disadvantage of centralized PFC is that the distribution lines of the installation, downstream of the PFC device, must be dimensioned taking into account the full reactive power required by the loads.

### 4.3 Circuit-breakers for the protection and switching of capacitor banks

The circuit-breakers for the protection and switching of capacitor banks in LV shall:

1. withstand the transient currents which occur when connecting and disconnecting the banks. In particular, the instantaneous magnetic and electronic releases shall not trip due to these peak currents;
2. withstand the periodic or permanent overcurrents due to the voltage harmonics and to the tolerance (+15%) of the rated value of capacity;
3. perform a high number of no-load and on-load operations, also with high frequency;
4. be coordinated with any external device (contactors).

Furthermore, the making and breaking capacity of the circuit-breaker must be adequate to the short-circuit current values of the installation.

Standards IEC 60831-1 and 60931-1 state that:

- the capacitors shall normally function with an effective current value up to 130% of their rated current  $I_{rc}$  (due to the possible presence of voltage harmonics in the network);
- a tolerance of +15% on the value of the capacity is allowed.

The maximum current which can be absorbed by the capacitor bank  $I_{cmax}$  is:

$$I_{cmax} = 1.3 \cdot 1.15 \cdot \frac{Q_c}{\sqrt{3} \cdot U_r} \approx 1.5 \cdot I_{rc} \quad (8)$$

Therefore:

- the rated current of the circuit-breaker shall be greater than  $1.5 \cdot I_{rc}$ ;
- the overload protection setting shall be equal to  $1.5 \cdot I_{rc}$ .

The connection of a capacitor bank, similar to a closing operation under short-circuit conditions, associated with transient currents with high frequency (1+15 kHz), of short duration (1+3 ms), with high peak (25+200  $I_{rc}$ ).

Therefore:

- the circuit-breaker shall have an adequate making capacity;
- the setting of the instantaneous short-circuit protection must not cause unwanted trips.

## 4 Power factor correction

The second condition is generally respected:

- for thermomagnetic releases, the magnetic protection shall be set at a value not less than  $10 \cdot I_{Cmax}$

$$I_3 \geq 10 \cdot I_{Cmax} = 15 \cdot I_{rc} = 15 \cdot \frac{Q_c}{\sqrt{3} \cdot U_r} \quad (9)$$

- for electronic releases, the instantaneous short-circuit protection shall be deactivated ( $I_3 = \text{OFF}$ ).

Hereunder, the selection tables for circuit-breakers: for the definition of the version according to the required breaking capacity, refer to Volume 1, Chapter 3.1 "General characteristics".

The following symbols are used in the tables (they refer to maximum values):

- $I_{nCB}$  = rated current of the protection release [A];
- $I_{rc}$  = rated current of the connected capacitor bank [A];
- $Q_C$  = power of the capacitor bank which can be connected [kvar] with reference to the indicated voltage and 50 Hz frequency;
- $N_{mech}$  = number of mechanical operations;
- $f_{mech}$  = frequency of mechanical operations [op/h];
- $N_{el}$  = number of electrical operations with reference to a voltage of 415 V for Tmax and Isomax moulded-case circuit breakers (Tables 5 and 6), and to a voltage of 440 V for Emax air circuit-breakers (Table 7);
- $f_{el}$  = frequency of electrical operations [op/h].

**Table 5: Selection table for Tmax moulded-case circuit-breakers**

CB Type	$I_{nCB}$	$I_{rc}$	$Q_C$ [kvar]				$N_{mech}$	$f_{mech}$	$N_{el}$	$f_{el}$
	[A]	[A]	400 V	440 V	500 V	690 V	[op/h]	[op/h]	[op/h]	
T1 B-C-N 160	160	107	74	81	92	127	25000	240	8000	120
T2 N-S-H-L 160*	160	107	74	81	92	127	25000	240	8000	120
T3 N-S 250*	250	166	115	127	144	199	25000	240	8000	120
T4 N-S-H-L-V 250	250	166	115	127	144	199	20000	240	8000	120
T4 N-S-H-L-V 320	320	212	147	162	184	254	20000	240	6000	120
T5 N-S-H-L-V 400	400	267	185	203	231	319	20000	120	7000	60
T6 N-S-H-L-V 630	630	421	291	302	364	502	20000	120	7000	60
T6 N-S-H-L 800	800	533	369	406	461	637	20000	120	5000	60
T7 S-H-L 1000	1000	666	461	507	576	795	10000	60	2000	60
T7 S-H-L 1250	1250	833	577	634	721	994	10000	60	2000	60
T7 S-H-L- 1600	1600	1067	739	813	924	1275	10000	60	2000	60

\*for plug-in version reduce the maximum power of the capacitor bank by 10%

**Table 6: Selection table for SACE Isomax S7 moulded-case circuit-breakers**

CB Type	$I_{nCB}$	$I_{rc}$	$Q_C$ [kvar]				$N_{mech}$	$f_{mech}$	$N_{el}$	$f_{el}$
	[A]	[A]	400 V	440 V	500 V	690 V	[op/h]	[op/h]	[op/h]	
S7 S-H-L 1250	1250	833	577	635	722	996	10000	120	7000	20
S7 S-H-L 1600	1600	1067	739	813	924	1275	10000	120	5000	20

## 4 Power factor correction

**Table 7: Selection table for SACE Emax air circuit-breakers**

CB Type	$I_{nCB}$	$I_{rc}$	$Q_C$ [kvar]				$N_{mech}$	$f_{mech}$	$N_{el}$	$f_{el}$
	(A)	(A)	400 V	440 V	500 V	690 V	(op/h)	(op/h)	(op/h)	
X1 B-N	630	421	291	320	364	502	12500	60	6000	30
X1 B-N	800	533	369	406	461	637	12500	60	6000	30
X1 B-N	1000	666	461	507	576	795	12500	60	4000	30
X1 B-N	1250	834	578	636	722	997	12500	60	4000	30
X1 B-N	1600	1067	739	813	924	1275	12500	60	3000	30
E1 B N	800	533	369	406	461	637	25000	60	10000	30
E1 B N	1000	666	461	507	576	795	25000	60	10000	30
E1 B N	1250	834	578	636	722	997	25000	60	10000	30
E1 B N	1600	1067	739	813	924	1275	25000	60	10000	30
E2 B-N-S	800	533	369	406	461	637	25000	60	15000	30
E2 B-N-S	1000	666	461	507	576	795	25000	60	15000	30
E2 B-N-S	1250	834	578	636	722	997	25000	60	15000	30
E2 B-N-S	1600	1067	739	813	924	1275	25000	60	12000	30
E2 B-N-S	2000	1334	924	1017	1155	1594	25000	60	10000	30
E3 N-S-H-V	800	533	369	406	461	637	20000	60	12000	20
E3 N-S-H-V	1000	666	461	507	576	795	20000	60	12000	20
E3 N-S-H-V	1250	834	578	636	722	997	20000	60	12000	20
E3 N-S-H-V	1600	1067	739	813	924	1275	20000	60	10000	20
E3 N-S-H-V	2000	1334	924	1017	1155	1594	20000	60	9000	20
E3 N-S-H-V	2500	1667	1155	1270	1444	1992	20000	60	8000	20
E3 N-S-H-V	3200	2134	1478	1626	1848	2550	20000	60	6000	20
E4 S-H-V	3200	2134	1478	1626	1848	2550	15000	60	7000	10
E6 H-V	3200	2134	1478	1626	1848	2550	12000	60	5000	10

## 5 Protection of human beings

### 5.1 General aspects: effects of current on human beings

Danger to persons due to contact with live parts is caused by the flow of the current through the human body. The effects are:

- **tetanzation:** the muscles affected by the current flow involuntary contract and letting go of gripped conductive parts is difficult. Note: very high currents do not usually induce muscular tetanization because, when the body touches such currents, the muscular contraction is so sustained that the involuntary muscle movements generally throw the subject away from the conductive part;
- **breathing arrest:** if the current flows through the muscles controlling the lungs, the involuntary contraction of these muscles alters the normal respiratory process and the subject may die due to suffocation or suffer the consequences of traumas caused by asphyxia;
- **ventricular fibrillation:** the most dangerous effect is due to the superposition of the external currents with the physiological ones which, by generating uncontrolled contractions, induce alterations of the cardiac cycle. This anomaly may become an irreversible phenomenon since it persists even when the stimulus has ceased;
- **burns:** they are due to the heating deriving, by Joule effect, from the current passing through the human body.

The Standard IEC 60479-1 "Effects of current on human being and livestock" is a guide about the effects of current passing through the human body to be used for the definition of electrical safety requirements. This Standard shows, on a time-current diagram, four zones to which the physiological effects of alternating current (15 +100 Hz) passing through the human body have been related.

## 5 Protection of human beings

Figure 1: Time-current zones of the effects of alternating current on the human body

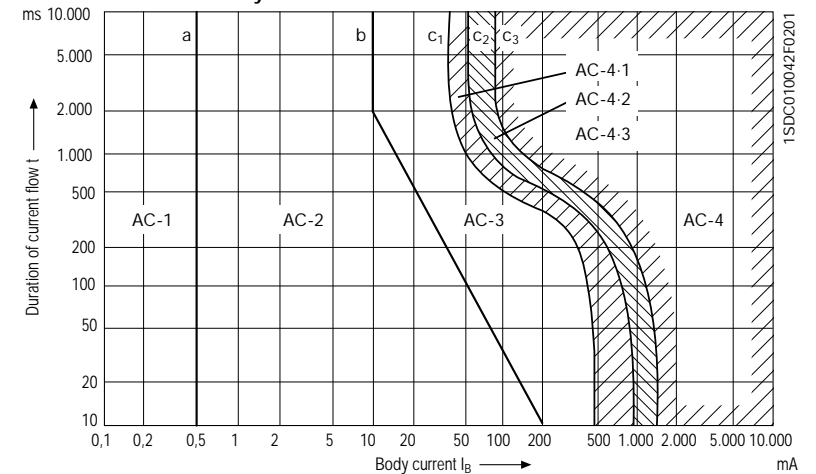

Zone designation	Zone limits	Physiological effects
AC-1	Up to 0.5 mA line a	Usually no reaction.
AC-2	0.5 mA up to line b*	Usually no harmful physiological effects.
AC-3	Line b up to curve c <sub>1</sub>	Usually no organic damage to be expected. Likelihood of cramplike muscular contractions and difficulty in breathing for durations of current-flow longer than 2 s. Reversible disturbances of formation and conduction of impulses in the heart, including atrial fibrillation and transient cardiac arrest without ventricular fibrillation increasing with current magnitude and time.
AC-4	Above curve c <sub>1</sub>	Increasing with magnitude and time, dangerous pathophysiological effects such as cardiac arrest, breathing arrest and severe burns may occur in addition to the effects of zone 3.
AC-4.1	c <sub>1</sub> - c <sub>2</sub>	Probability of ventricular fibrillation increasing up to about 5%.
AC-4.2	c <sub>2</sub> - c <sub>3</sub>	Probability of ventricular fibrillation up to about 50%.
AC-4.3	Beyond curve c <sub>3</sub>	Probability of ventricular fibrillation above 50%.

\* For durations of current-flow below 10 ms, the limit for the body current for line b remains constant at a value of 200 mA.

This Standard gives also a related figure for direct current. By applying Ohm's law it is possible to define the safety curve for the allowable voltages, once the human body impedance has been calculated. The electrical impedance of the human body depends on many factors. The above mentioned Standard gives different values of impedance as a function of the touch voltage and of the current path.



## 5 Protection of human beings

The Standard IEC 60479-1 has adopted precautionary values for the impedance reported in the figure so as to get the time-voltage safety curve (Figure 2) related to the total touch voltage  $U_T$  (i.e. the voltage which, due to an insulation failure, is present between a conductive part and a point of the ground sufficiently far, with zero potential).

This represents the maximum no-load touch voltage value; thus, the most unfavorable condition is taken into consideration for safety's sake.

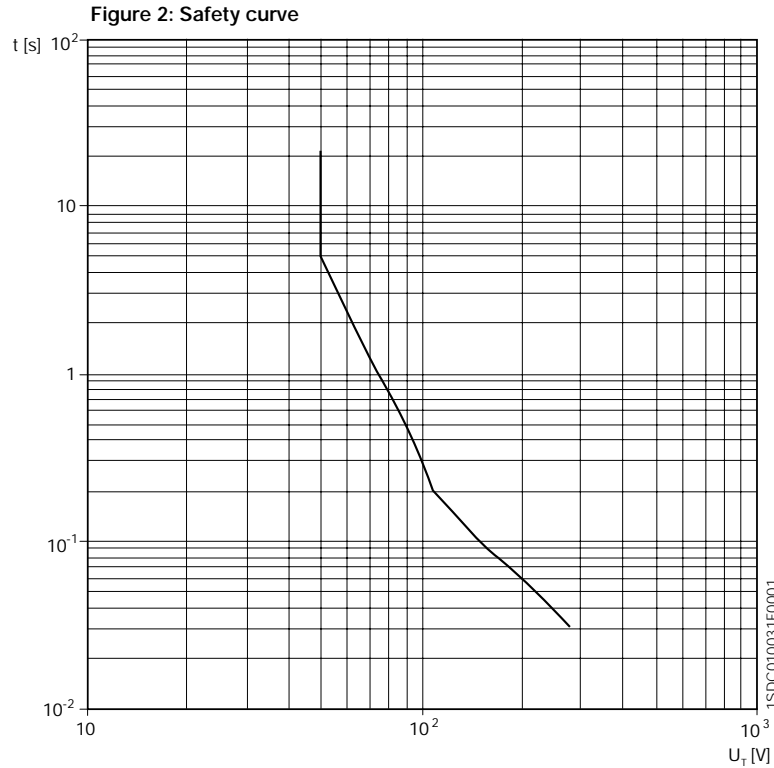

From this safety curve it results that for all voltage values below 50 V, the tolerance time is indefinite; at 50 V the tolerance time is 5 s. The curve shown in the figure refers to an ordinary location; in particular locations, the touch resistance of the human body towards earth changes and consequently the tolerable voltage values for an indefinite time shall be lower than 25 V.

Therefore, if the protection against indirect contact is obtained through the disconnection of the circuit, it is necessary to ensure that such breaking is carried out in compliance with the safety curve for any distribution system.

## 5 Protection of human beings

### 5.2 Distribution systems

The earth fault modalities and the consequences caused by contact with live parts, are strictly related to the neutral conductor arrangement and to the connections of the exposed conductive parts.

For a correct choice of the protective device, it is necessary to know which is the distribution system of the plant.

IEC 60364-1 classifies the distribution systems with two letters.

The first letter represents the relationship of the power system to earth:

- T: direct connection of one point to earth, in alternating current systems, generally the neutral point;
- I: all live parts isolated from earth, or one point, in alternating current systems, generally the neutral point, connected to earth through an impedance.

The second letter represents the relationship of the exposed conductive parts of the installation to earth:

- T: direct electrical connection of the exposed conductive parts to earth;
- N: direct electrical connection of the exposed conductive parts to the earthed point of the power system.

Subsequent letters, if any, represent the arrangement of neutral and protective conductors:

- S: protective function is provided by a conductor separate from the neutral conductor;
- C: neutral and protective functions combined as a single conductor (PEN conductor).

Three types of distribution system are considered:

#### TT System

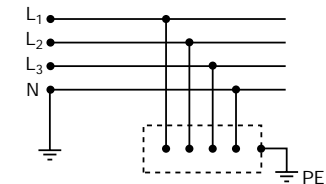

#### TN System

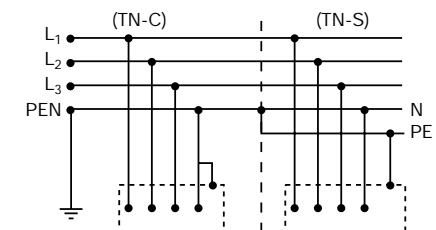

## 5 Protection of human beings

### IT System

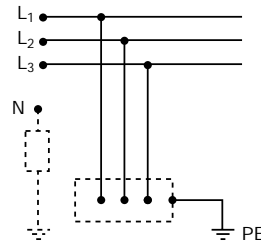

1SDC010034F0001

In **TT** systems, the neutral conductor and the exposed conductive parts are connected to earth electrodes electrically independent; the fault current flows towards the power supply neutral point through earth (Fig. 1):

Figure 1: Earth fault in TT systems

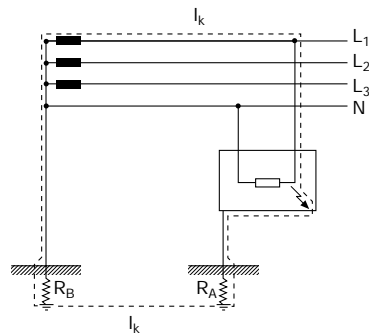

1SDC010035F0001

In **TT** installations, the neutral conductor is connected to the supply star center, it is usually distributed and has the function of making the phase voltage (e.g. 230 V) available, useful for single-phase load supply. The exposed conductive parts, on the contrary, singularly or collectively, are locally connected to earth. **TT** systems are generally used for civil installations.

**TN** systems are typically used when the power supply is distributed to loads having their own electrical substation. The neutral conductor is directly earthed in the substation; the exposed conductive parts are connected to the same earthing point of the neutral conductor, and can be locally earthed.

Three types of **TN** system are considered according to the arrangement of neutral and protective conductors:

1. **TN-C** neutral and protective functions are combined in a single conductor (PEN conductor);
2. **TN-S** neutral and protective conductors are always separated;
3. **TN-C-S** neutral and protective functions are combined in a single conductor in a part of the system (PEN) and are separated in another part (PE + N).

## 5 Protection of human beings

In **TN** systems, the fault current flows towards the power supply neutral point through a solid metallic connection, practically without involving the earth electrode (Figure 2).

Figure 2: Earth fault in TN systems

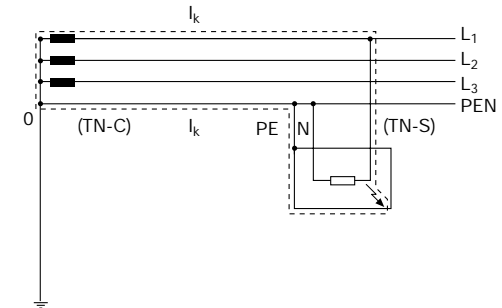

1SDC010036F0001

**IT** systems have no live parts directly connected to earth, but they can be earthed through a sufficiently high impedance. Exposed conductive parts shall be earthed individually, in groups or collectively to an independent earthing electrode.

The earth fault current flows towards the power supply neutral point through the earthing electrode and the line conductor capacitance (Figure 3).

Figure 3: Earth fault in IT systems

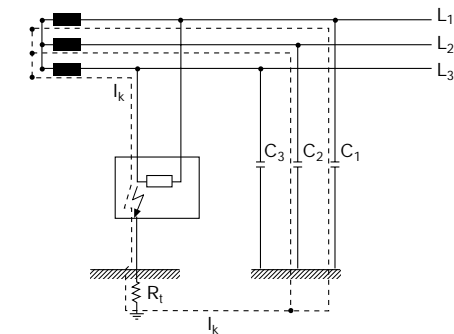

1SDC010037F0001

These distribution systems are used for particular plants, where the continuity of supply is a fundamental requirement, where the absence of the supply can cause hazards to people or considerable economical losses, or where a low value of a first earth fault is required. In these cases, an insulation monitoring device shall be provided for optical or acoustic signalling of possible earth faults, or failure of the supplied equipment.

## 5 Protection of human beings

### 5.3 Protection against both direct and indirect contact

Contacts of a person with live parts can be divided in two categories:

- direct contacts;
- indirect contacts.

A direct contact occurs when a part of the human body touches a part of the plant, usually live (bare conductors, terminals, etc.).

A contact is indirect when a part of the human body touches an exposed conductive parts, usually not live, but with voltage presence due to a failure or wear of the insulating materials.

The measures of protection against **direct contact** are:

- insulation of live parts with an insulating material which can only be removed by destruction (e.g. cable insulation);
- barriers or enclosures: live parts shall be inside enclosures or behind barriers providing at least the degree of protection IPXXB or IP2X; for horizontal surfaces the degree of protection shall be of at least IPXXD or IP4X (for the meaning of the degree of protection codes please refer to Volume 1, Chapter 6.1 Electrical switchboards);
- obstacles: the interposition of an obstacle between the live parts and the operator prevents unintentional contacts only, but not an intentional contact by the removal of the obstacle without particular tools;
- placing out of reach: simultaneously accessible parts at different potentials shall not be within arm's reach.

An additional protection against direct contact can be obtained by using residual current devices with a rated operating residual current not exceeding 30 mA. It must be remembered that the use of a residual current device as a mean of protection against direct contacts does not obviate the need to apply one of the above specified measures of protection.

The measures of protection against **indirect contact** are:

- automatic disconnection of the supply: a protective device shall automatically disconnect the supply to the circuit so that the touch voltage on the exposed conductive part does not persist for a time sufficient to cause a risk of harmful physiological effect for human beings;
- supplementary insulation or reinforced insulation, e.g. by the use of Class II components;

## 5 Protection of human beings

- non-conducting locations: locations with a particular resistance value of insulating floors and walls ( $\geq 50 \text{ k}\Omega$  for  $U_r \leq 500 \text{ V}$ ;  $\geq 100 \text{ k}\Omega$  for  $U_r > 500 \text{ V}$ ) and without protective conductors inside
- electrical separation, e.g. by using an isolating transformer to supply the circuit;
- earth-free local equipotential bonding: locations where the exposed conductive parts are connected together but not earthed.

Finally, the following measures provide combined protection against both direct and indirect contact:

- SELV (Safety Extra Low Voltage) system and PELV (Protective Extra Low Voltage) system;
- FELV (Functional Extra Low Voltage) system.

The protection against both direct and indirect contact is ensured if the requirements stated in 411 from IEC 60364-4-41 are fulfilled; particularly:

- the rated voltage shall not exceeds 50 V ac r.m.s. and 120 V ripple-free dc;
- the supply shall be a SELV or PELV source;
- all the installation conditions provided for such types of electrical circuits shall be fulfilled.

A SELV circuit has the following characteristics:

- 1) it is supplied by an independent source or by a safety source. Independent sources are batteries or diesel-driven generators. Safety sources are supplies obtained through an isolating transformer;
- 2) there are no earthed points. The earthing of both the exposed conductive parts as well as of the live parts of a SELV circuit is forbidden;
- 3) it shall be separated from other electrical systems. The separation of a SELV system from other circuits shall be guaranteed for all the components; for this purpose, the conductors of the SELV circuit may be contained in multi-conductor cables or may be provided with an additional insulating sheath.

A PELV circuit has the same prescription of a SELV system, except for the prohibition of earthed points; in fact in PELV circuits, at least one point is always earthed.

## 5 Protection of human beings

FELV circuits are used when for functional reasons the requirements for SELV or PELV circuits cannot be fulfilled; they require compliance with the following rules:

- a) protection against direct contact shall be provided by either:
  - barriers or enclosures with degree of protection in accordance with what stated above (measures of protection against direct contact);
  - insulation corresponding to the minimum test voltage specified for the primary circuit. If this test is not passed, the insulation of accessible non-conductive parts of the equipment shall be reinforced during erection so that it can withstand a test voltage of 1500 V ac r.m.s. for 1 min.;
- b) protection against indirect contact shall be provided by:
  - connection of the exposed conductive parts of the equipment of the FELV circuit to the protective conductor of the primary circuit, provided that the latter is subject to one of the measures of protection against direct contact;
  - connection of a live conductor of the FELV circuit to the protective conductor of the primary circuit provided that an automatic disconnection of the supply is applied as measure of protection;
- c) plugs of FELV systems shall not be able to enter socket-outlets of other voltage systems, and plugs of other voltage systems shall not be able to enter socket-outlets of FELV systems.

Figure 1 shows the main features of SELV, PELV and FELV systems.

Figure 1: SELV, PELV, FELV systems

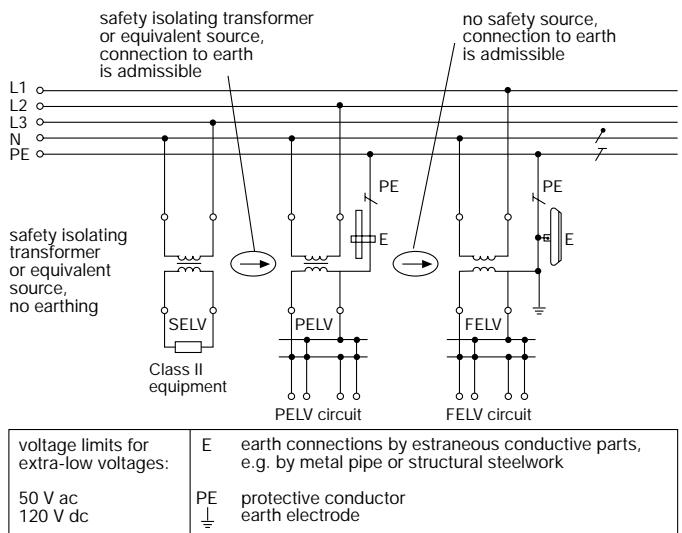

Note 1: Overcurrent protective devices are not shown in this figure.

## 5 Protection of human beings

### 5.4 TT System

An earth fault in a TT system involves the circuit represented in Figure 1:

Figure 1: Earth fault in TT system

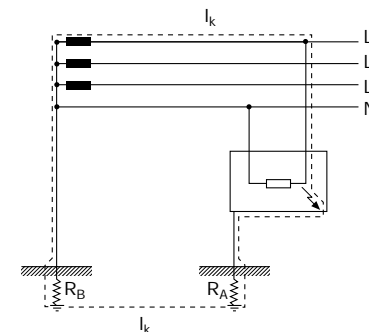

The fault current involves the secondary winding of the transformer, the phase conductor, the fault resistance, the protective conductor and the earth electrode resistance (plant earthing system ( $R_A$ ) and earthing system which the neutral is connected to ( $R_B$ )).

According to IEC 60364-4 requirements, the protective devices must be coordinated with the earthing system in order to rapidly disconnect the supply, if the touch voltage reaches harmful values for the human body.

Assuming 50 V (25 V for particular locations) as limit voltage value, the condition to be fulfilled in order to limit the touch voltage on the exposed conductive parts under this limit value is:

$$R_t \leq \frac{50}{I_a} \quad \text{or} \quad R_t \leq \frac{50}{I_{\Delta n}}$$

where:

- $R_t$  is the total resistance, equal to the sum of the earth electrode ( $R_A$ ) and the protective conductor for the exposed conductive parts [ $\Omega$ ];
- $I_a$  is the current causing the automatic operation within 5 s of the overcurrent protective device, read from the tripping curve of the device [A];
- $I_{\Delta n}$  is the rated residual operating current, within one second, of the circuit-breaker [A].

## 5 Protection of human beings

From the above, it is clear that  $R_t$  value is considerably different when using automatic circuit-breakers instead of residual current devices.

In fact, with the former, it is necessary to obtain very low earth resistance values (usually less than  $1 \Omega$ ) since the 5 s tripping current is generally high, whereas, with the latter, it is possible to realize earthing systems with resistance value of thousands of ohms, which are easier to be carried out.

Table 1 reports the maximum earth resistance values which can be obtained using residual current devices, with reference to an ordinary location (50 V):

**Table 1: Earth resistance values**

$I_{\Delta n}$ [A]	$R_t$ [ $\Omega$ ]
0.01	5000
0.03	1666
0.1	500
0.3	166
0.5	100
3	16
10	5
30	1.6

**Example:**

Assuming to provide protection by using an automatic circuit-breaker Tmax T1B160 In125, the trip current value in less than 5 s, read from the tripping characteristic curve, is about 750 A, when starting from cold conditions (the worst case for thermomagnetic releases).

So:

$$R_t \leq \frac{50}{750} = 0.06 \Omega$$

In order to provide the required protection, it must be necessary to carry out an earthing system with an earth resistance  $R_t \leq 0.06 \Omega$ , which is not an easily obtainable value.

On the contrary, by using the same circuit-breaker mounting ABB SACE RC221 residual current release, with rated residual operating current  $I_{\Delta n} = 0.03$  A, the required value of earth resistance is:

$$R_t \leq \frac{50}{0.03} = 1666.6 \Omega$$

which can be easily obtained in practice.

## 5 Protection of human beings

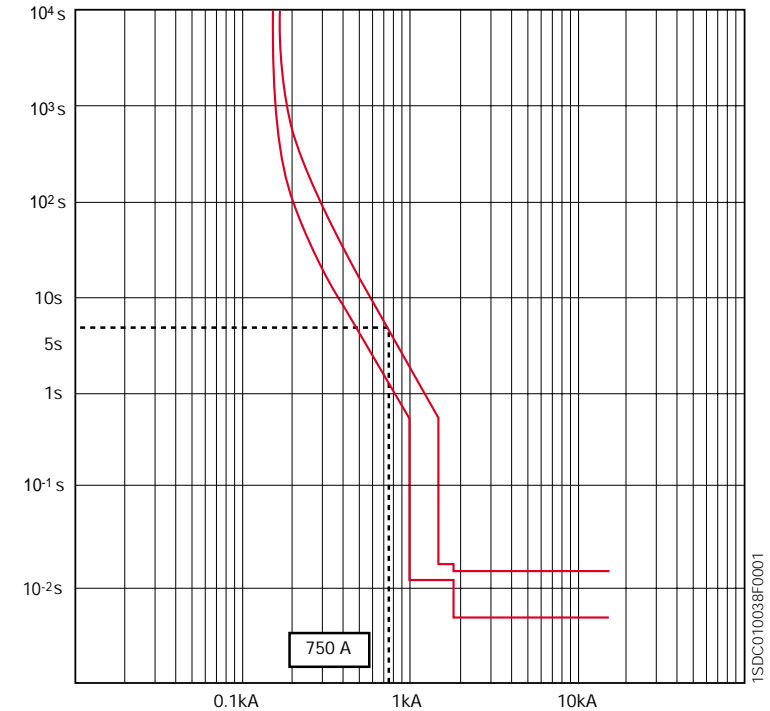

In an electrical installation with a common earthing system and loads protected by devices with different tripping currents, for the achievement of the coordination of all the loads with the earthing system, the worst case - represented by the device with the highest tripping current - shall be considered.

As a consequence, when some feeders are protected by overcurrent devices and some others by residual current devices, all the advantages deriving from the use of residual current releases are nullified, since the  $R_t$  shall be calculated on the basis of the  $I_{5s}$  of the overcurrent device and since it is the highest tripping current between these two kind of devices.

Therefore, it is advisable to protect all the loads of a TT system by means of residual current circuit-breakers coordinated with the earthing system to obtain the advantages of both a quick disconnection of the circuit when the fault occurs as well as an earthing system which can be easily accomplished.

## 5 Protection of human beings

### 5.5 TN System

An earth fault in a TN system involves the circuit represented in Figure 1:

Figure 1: Earth fault in TN system

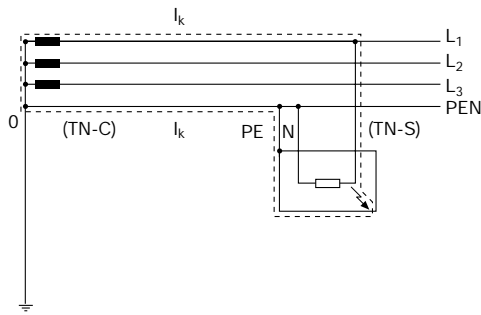

1SDC010036F0001

The fault loop does not affect the earthing system and is basically formed by the connection in series of the phase conductor and of the protective conductor. To provide a protection with automatic disconnection of the circuit, according to IEC 60364-4 prescriptions, the following condition shall be fulfilled:

$$Z_s \cdot I_a \leq U_0$$

where:

- $Z_s$  is the impedance of the fault loop comprising the source, the live conductor up to the point of the fault and the protective conductor between the point of the fault and the source [ $\Omega$ ];
- $U_0$  is the nominal ac r.m.s. voltage to earth [V];
- $I_a$  is the current causing the automatic operation of the disconnecting protective device within the time stated in Table 1, as a function of the rated voltage  $U_0$  or, for distribution circuits, a conventional disconnecting time not exceeding 5 s is permitted [A]; if the protection is provided by means of a residual current device,  $I_a$  is the rated residual operating current  $I_{\Delta n}$ .

Table 1: Maximum disconnecting times for TN system

$U_0$ [V]	Disconnecting time [s]
120	0.8
230	0.4
400	0.2
> 400	0.1

## 5 Protection of human beings

In TN installations, an earth fault with low impedance occurring on the LV side causes a short circuit current with quite high value, due to the low value of the impedance of the fault loop. The protection against indirect contact can be provided by automatic circuit-breakers: it is necessary to verify that the operating current within the stated times is lower than the short-circuit current.

The use of residual current devices improves the conditions for protection in particular when the fault impedance doesn't have a low value, thus limiting the short-circuit current; this current can persist for quite long time causing overheating of the conductors and fire risks.

Finally, it is important to highlight the fact that the residual current devices cannot be used in TN-C system, since the neutral and protective functions are provided by a unique conductor: this configuration prevents the residual current device from working.

### Example:

In the plant represented in Figure 2, the earth fault current is:

$$I_{kLG} = 3 \text{ kA}$$

The rated voltage to earth is 230 V, therefore, according to Table 1, it shall be verified that:

$$I_a (0.4s) \leq \frac{U_0}{Z_s} = I_{kLG} = 3 \text{ kA}$$

Figure 2

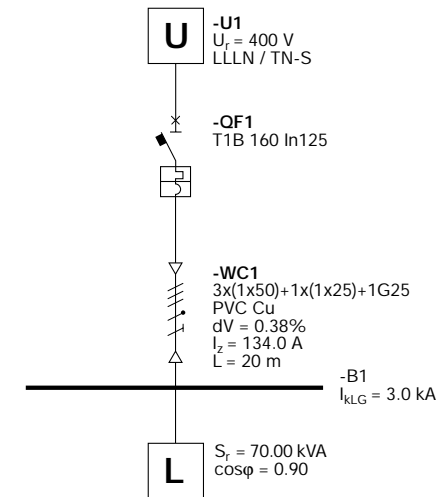

1SDC010039F0001

## 5 Protection of human beings

From the tripping curve (Figure 3), it is clear that the circuit-breaker trips in 0.4 s for a current value lower than 950 A. As a consequence, the protection against indirect contact is provided by the same circuit-breaker which protects the cable against short-circuit and overload, without the necessity of using an additional residual current device.

Figure 3: LG Time-Current curves

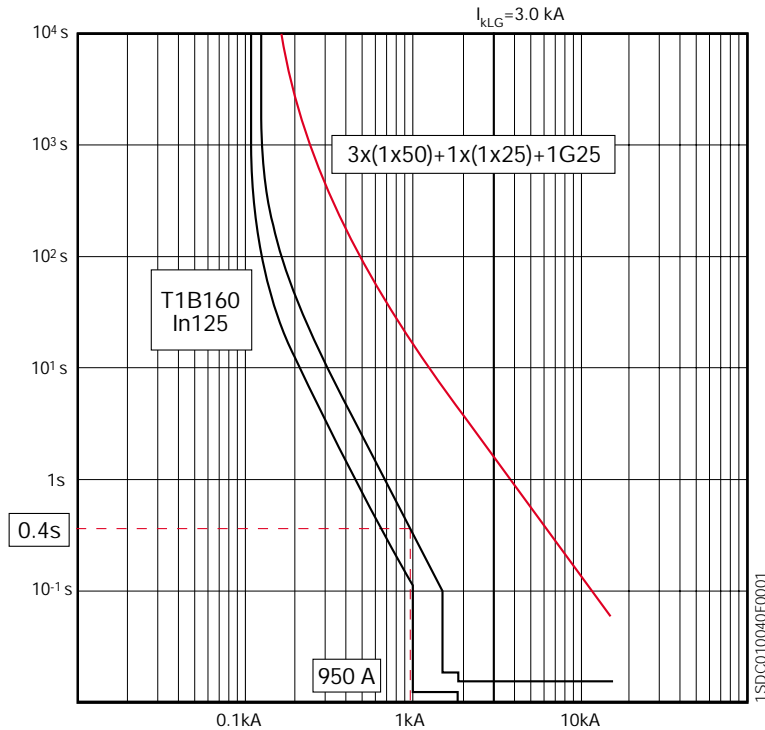

## 5 Protection of human beings

### 5.6 IT System

As represented in Figure 1, the earth fault current in an IT system flows through the line conductor capacitance to the power supply neutral point. For this reason, the first earth fault is characterized by such an extremely low current value to prevent the overcurrent protections from disconnecting; the deriving touch voltage is very low.

Figure1: Earth fault in IT system

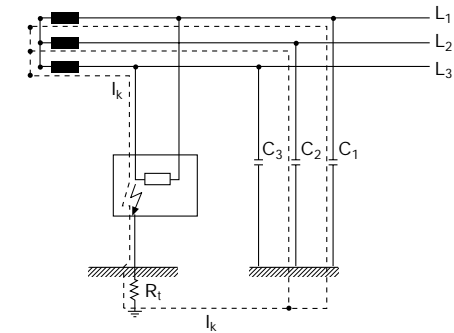

According to IEC 60364-4, the automatic disconnection of the circuit in case of the first earth fault is not necessary only if the following condition is fulfilled:

$$R_t \cdot I_d \leq U_L$$

where:

- $R_t$  is the resistance of the earth electrode for exposed conductive parts [ $\Omega$ ];
- $I_d$  is the fault current, of the first fault of negligible impedance between a phase conductor and an exposed conductive part [A];
- $U_L$  is 50 V for ordinary locations (25 V for particular locations).

If this condition is fulfilled, after the first fault, the touch voltage value on the exposed conductive parts is lower than 50 V, tolerable by the human body for an indefinite time, as shown in the safety curve (see Chapter 5.1 "General aspects: effects of current on human beings").

In IT system installations, an insulation monitoring device shall be provided to

## 5 Protection of human beings

indicate the occurrence of a first earth fault; in the event of a second fault, the supply shall be disconnected according to the following modalities:

- where exposed conductive parts are earthed in groups or individually, the conditions for protection are the same as for TT systems (see Chapter 5.4 "TT system");
- where exposed conductive parts are interconnected by a protective conductor collectively earthed, the conditions of a TN system apply; in particular, the following conditions shall be fulfilled:  
if the neutral is not distributed:

$$Z_s \leq \frac{U_r}{2 \cdot I_a}$$

if the neutral is distributed:

$$Z'_s \leq \frac{U_0}{2 \cdot I_a}$$

where

- $U_0$  is the rated voltage between phase and neutral [V];
- $U_r$  is the rated voltage between phases [V];
- $Z_s$  is the impedance of the fault loop comprising the phase conductor and the protective conductor of the circuit [ $\Omega$ ];
- $Z'_s$  is the impedance of the fault loop comprising the neutral conductor and the protective conductor of the circuit [ $\Omega$ ];
- $I_a$  is the operating current of the protection device in the disconnecting time specified in Table 1, or within 5 s for distribution circuits.

**Table 1: Maximum disconnecting time in IT systems**

Rated voltage $U_0/U_r$ [V]	disconnecting time [s]	
	neutral not distributed	neutral distributed
120/240	0.8	5
230/400	0.4	0.8
400/690	0.2	0.4
580/1000	0.1	0.2

IEC 60364-4 states that, if the requirements mentioned at point b) cannot be fulfilled by using an overcurrent protective device, the protection of every supplied load shall be provided by means of a residual current device.

The residual current device threshold shall be carefully chosen in order to avoid unwanted tripping, due also to the particular path followed by the first fault current through the line conductor capacitance to the power supply neutral point (instead of the faulted line, another sound line with higher capacitance could be affected by a higher fault current value).

## 5 Protection of human beings

### 5.7 Residual current devices (RCDs)

#### Generalities on residual current circuit-breakers

The operating principle of the residual current release is basically the detection of an earth fault current, by means of a toroid transformer which embraces all the live conductors, included the neutral if distributed.

**Figure 1: Operating principle of the residual current device**

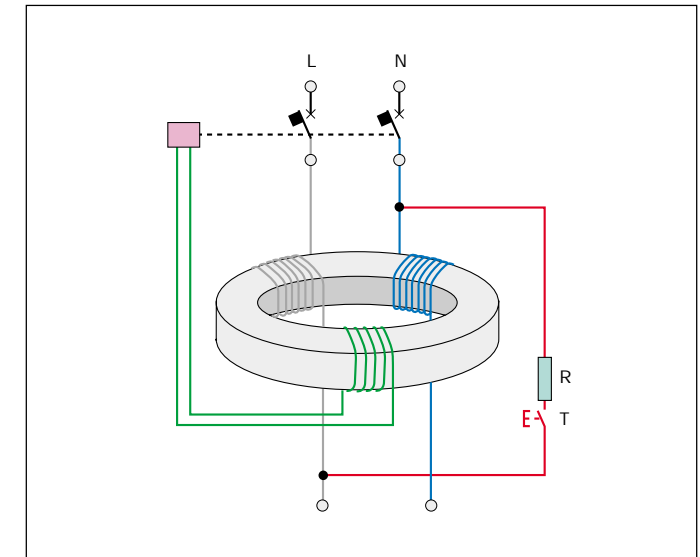

1SDC010041F0001

In absence of an earth fault, the vectorial sum of the currents  $I_{\Delta}$  is equal to zero; in case of an earth fault if the  $I_{\Delta}$  value exceeds the rated residual operating current  $I_{\Delta n}$ , the circuit at the secondary side of the toroid sends a command signal to a dedicated opening coil causing the tripping of the circuit-breaker. A first classification of RCDs can be made according to the type of the fault current they can detect:

- AC type: the tripping is ensured for residual sinusoidal alternating currents, whether suddenly applied or slowly rising;
- A type: tripping is ensured for residual sinusoidal alternating currents and residual pulsating direct currents, whether suddenly applied or slowly rising;
- B type: tripping is ensured for residual direct currents, for residual sinusoidal alternating currents and residual pulsating direct currents, whether suddenly applied or slowly rising.

Another classification referred to the operating time delay is:

- undelayed type;
- time delayed S-type.



## 5 Protection of human beings

RCDs can be coupled, or not, with other devices; it is possible to distinguish among:

- pure residual current circuit-breakers (RCCBs): they have only the residual current release and can protect only against earth fault. They must be coupled with thermomagnetic circuit-breakers or fuses, for the protection against thermal and dynamical stresses;
- residual current circuit-breakers with overcurrent protection (RCBOs): they are the combination of a thermomagnetic circuit-breaker and a RCD; for this reason, they provide the protection against both overcurrents as well as earth fault current;
- residual current circuit-breakers with external toroid: they are used in industrial plants with high currents. They are composed by a release connected to an external toroid with a winding for the detection of the residual current; in case of earth fault, a signal commands the opening mechanism of a circuit-breaker or a line contactor.

Given  $I_{\Delta n}$  the operating residual current, a very important parameter for residual current devices is the residual non-operating current, which represents the maximum value of the residual current which does not cause the circuit-breaker trip; it is equal to  $0.5 I_{\Delta n}$ . Therefore, it is possible to conclude that:

- for  $I_{\Delta} < 0.5 I_{\Delta n}$  the RCD shall not operate;
- for  $0.5 I_{\Delta n} < I_{\Delta} < I_{\Delta n}$  the RCD could operate;
- for  $I_{\Delta} > I_{\Delta n}$  the RCD shall operate.

For the choice of the rated operating residual current, it is necessary to consider, in addition to the coordination with the earthing system, also the whole of the leakage currents in the plant; their vectorial sums on each phase shall not be greater than  $0.5 I_{\Delta n}$ , in order to avoid unwanted tripping.

### Discrimination between RCDs

The Standard IEC 60364-5-53 states that discrimination between residual current protective devices installed in series may be required for service reasons, particularly when safety is involved, to provide continuity of supply to the parts of the installation not involved by the fault, if any. This discrimination can be achieved by selecting and installing RCDs in order to provide the disconnection from the supply by the RCD closest to the fault.

There are two types of discrimination between RCDs:

- horizontal discrimination: it provides the protection of each line by using a dedicated residual current circuit-breaker; in this way, in case of earth fault, only the faulted line is disconnected, since the other RCDs do not detect any fault current. However, it is necessary to provide protective measures against indirect contacts in the part of the switchboard and of the plant upstream the RCD;
- vertical discrimination: it is realized by using RCDs connected in series.

Figure 2: Horizontal discrimination between RCDs

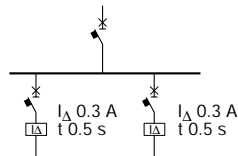

## 5 Protection of human beings

Figure 3: Vertical discrimination between RCDs

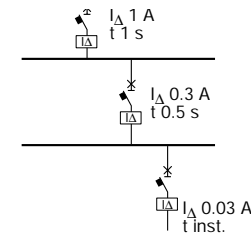

According to IEC 60364-5-53, to ensure discrimination between two residual current protective devices in series, these devices shall satisfy both the following conditions:

- the non-actuating time-current characteristic of the residual current protective device located on the supply side (upstream) shall lie above the total operating time-current characteristic of the residual current protective device located on the load side (downstream);
- the rated residual operating current on the device located on the supply side shall be higher than that of the residual current protective device located on the load side.

**The non-actuating time-current characteristic** is the curve reporting the maximum time value during which a residual current greater than the residual non-operating current (equal to  $0.5 I_{\Delta n}$ ) involves the residual current circuit-breaker without causing the tripping.

As a conclusion, discrimination between two RCDs connected in series can be achieved:

- for S type residual current circuit-breakers, located on the supply side, (complying with IEC 61008-1 and IEC 61009), time-delayed type, by choosing general type circuit-breakers located downstream with  $I_{\Delta n}$  equal to one third of  $I_{\Delta n}$  of the upstream ones;
- for electronic residual current releases (RC221/222/223, RCQ) by choosing the upstream device with time and current thresholds directly greater than the downstream device, keeping carefully into consideration the tolerances (see Vol. 1, Chapter 2.3: Type of release).

For the protection against indirect contacts in distribution circuits in TT system, the maximum disconnecting time at  $I_{\Delta n}$  shall not exceed 1 s (IEC 60364-4-41, § 413.1)

## 5 Protection of human beings

### 5.8 Maximum protected length for the protection of human beings

As described in the previous chapters, the Standards give indications about the maximum disconnecting time for the protective devices, in order to avoid pathophysiological effects for people touching live parts.

For the protection against indirect contact, it shall be verified that the circuit-breaker trips within a time lower than the maximum time stated by the Standard; this verification is carried out by comparing the minimum short-circuit current of the exposed conductive part to be protected with the operating current corresponding to the time stated by the Standard.

The minimum short-circuit current occurs when there is a short-circuit between the phase and the protective conductors at the farthest point on the protected conductor.

For the calculation of the minimum short-circuit current, an approximate method can be used, assuming that:

- a 50 % increasing of the conductors resistance, with respect to the 20 °C value, is accepted, due to the overheating caused by the short-circuit current;
- a 80 % reduction of the supply voltage is considered as effect of the short-circuit current;
- the conductor reactance is considered only for cross sections larger than 95 mm<sup>2</sup>.

The formula below is obtained by applying Ohm's law between the protective device and the fault point.

*Legend of the symbols and constants of the formula:*

- 0.8 is the coefficient representing the reduction of the voltage;
- 1.5 is the coefficient representing the increasing in the resistance;
- $U_r$  is the rated voltage between phases;
- $U_0$  is the rated voltage between phase and ground;
- $S$  is the phase conductor cross section;
- $S_N$  is the neutral conductor cross section;
- $S_{PE}$  is the protection conductor cross section;
- $\rho$  is the conductor resistivity at 20 °C;
- $L$  is the length of the cable;

-  $m = \frac{S \cdot n}{S_{PE}}$  is the ratio between the total phase conductor cross section

(single phase conductor cross section  $S$  multiplied by  $n$ , number of conductors in parallel) and the protective conductor cross section  $S_{PE}$  assuming they are made of the same conductor material;

-  $m_1 = \frac{S_N \cdot n}{S_{PE}}$  is the ratio between the total neutral conductor cross section

(single neutral conductor cross section  $S_N$  multiplied by  $n$ , number of conductors in parallel) and the protective conductor cross section  $S_{PE}$  assuming they are made of the same conductor material;

-  $k_1$  is the correction factor which takes into account the reactance of cables with cross section larger than 95 mm<sup>2</sup>, obtainable from the following table:

Phase conductor cross section [mm <sup>2</sup> ]	120	150	185	240	300
$k_1$	0.90	0.85	0.80	0.75	0.72

## 5 Protection of human beings

- $k_2$  is the correction factor for conductors in parallel, obtainable by the following formula:

$$k_2 = 4 \frac{n-1}{n}$$

where  $n$  is the number of conductor in parallel per phase;

- 1.2 is the magnetic threshold tolerance allowed by the Standard.

### TN system

The formula for the evaluation of the minimum short circuit current is:

$$I_{kmin} = \frac{0.8 \cdot U_0 \cdot S}{1.5 \cdot 1.2 \cdot \rho \cdot (1+m) \cdot L} \cdot k_1 \cdot k_2$$

and consequently:

$$L = \frac{0.8 \cdot U_0 \cdot S}{1.5 \cdot 1.2 \cdot \rho \cdot (1+m) \cdot I_{kmin}} \cdot k_1 \cdot k_2$$

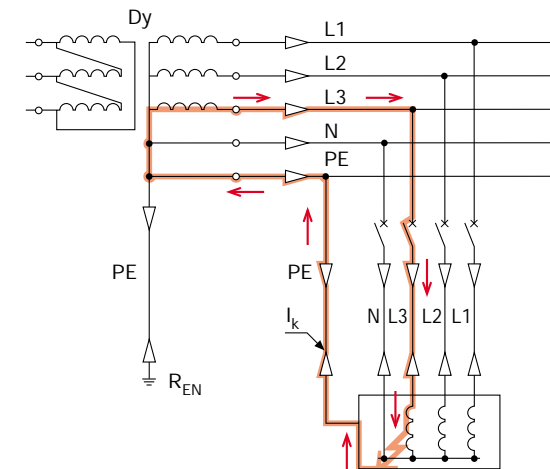

1SDC010043F0001

### IT system

The formulas below are valid when a second fault turns the IT system into a TN system.

It is necessary to separately examine installations with neutral not distributed and neutral distributed.

## 5 Protection of human beings

### Neutral not distributed

When a second fault occurs, the formula becomes:

$$I_{k\min} = \frac{0.8 \cdot U_r \cdot S}{2 \cdot 1.5 \cdot 1.2 \cdot \rho \cdot (1+m) \cdot L} \cdot k_1 \cdot k_2$$

and consequently:

$$L = \frac{0.8 \cdot U_r \cdot S}{2 \cdot 1.5 \cdot 1.2 \cdot \rho \cdot (1+m) \cdot I_{k\min}} \cdot k_1 \cdot k_2$$

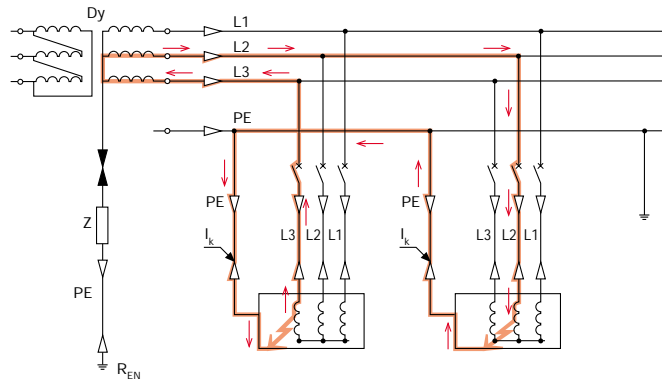

1SDC010044F0001

### Neutral distributed

Case A: three-phase circuits in IT system with neutral distributed  
The formula is:

$$I_{k\min} = \frac{0.8 \cdot U_0 \cdot S}{2 \cdot 1.5 \cdot 1.2 \cdot \rho \cdot (1+m) \cdot L} \cdot k_1 \cdot k_2$$

and consequently:

$$L = \frac{0.8 \cdot U_0 \cdot S}{2 \cdot 1.5 \cdot 1.2 \cdot \rho \cdot (1+m) \cdot I_{k\min}} \cdot k_1 \cdot k_2$$

Case B: three-phase + neutral circuits in IT system with neutral distributed

The formula is:

$$I_{k\min} = \frac{0.8 \cdot U_0 \cdot S_N}{2 \cdot 1.5 \cdot 1.2 \cdot \rho \cdot (1+m_1) \cdot L} \cdot k_1 \cdot k_2$$

and consequently:

$$L = \frac{0.8 \cdot U_0 \cdot S_N}{2 \cdot 1.5 \cdot 1.2 \cdot \rho \cdot (1+m_1) \cdot I_{k\min}} \cdot k_1 \cdot k_2$$

## 5 Protection of human beings

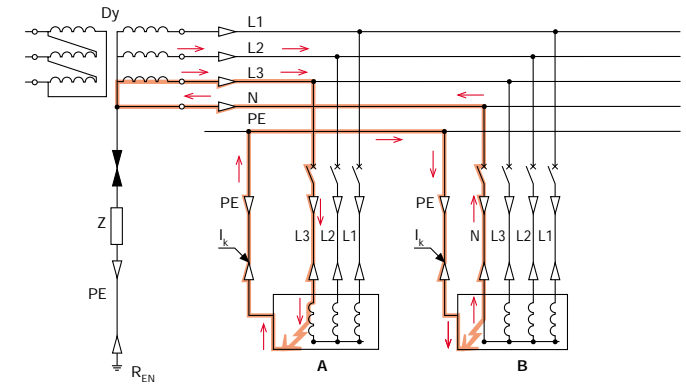

1SDC010045F0001

### Note for the use of the tables

The tables showing the maximum protected length (MPL) have been defined considering the following conditions:

- one cable per phase;
- rated voltage equal to 400 V (three-phase system);
- copper cables;
- neutral not distributed, for IT system only;
- protective conductor cross section according to Table 1:

**Table 1: Protective conductor cross section**

Phase conductor cross section S [mm <sup>2</sup> ]	Protective conductor cross section S <sub>PE</sub> [mm <sup>2</sup> ]
S ≤ 16	S
16 < S ≤ 35	16
S > 35	S/2

Note: phase and protective conductors having the same isolation and conductive materials

Whenever the S function (delayed short-circuit) of electronic releases is used for the definition of the maximum protected length, it is necessary to verify that the tripping time is lower than the time value reported in Chapter 5.5 Table 1 for TN systems and in Chapter 5.6 Table 1 for IT systems.

For conditions different from the reference ones, the following correction factors shall be applied.

## 5 Protection of human beings

### Correction factors

**Correction factor for cable in parallel per phase:** the value of the maximum protected length read in Table 2 (TN system) or Table 3 (IT system) shall be multiplied by the following factor:

n	2	3	4	5	6	7	8
$k_p$	2	2.7	3	3.2	3.3	3.4	3.5

n is the number of conductors in parallel per phase.

**Correction factor for three-phase voltage different from 400 V:** the value of the maximum protected length read in Table 2 (TN system) or Table 3 (IT system) shall be multiplied by the following factor:

voltage [V]	230	400	440	500	690
$k_v$	0.58	1	1.1	1.25	1.73

For 230 V single-phase systems, no correction factor is necessary.

**Correction factor for aluminium cables:** the value of the maximum protected length read in Table 2 (TN system) or Table 3 (IT system) shall be multiplied by the following factor:

$k_{Al}$	0.64
----------	------

**Correction factor for protective conductor cross section  $S_{PE}$  different from the cross sections stated in Table 1:** the value of the maximum protected length shall be multiplied by the coefficient corresponding to the phase conductor cross section and to the ratio between the protective conductor (PE) and the phase cross sections:

$S_{PE}/S$	0.5	0.55	0.6	0.66	0.75	0.87	1	1.25	1.5	2
	$k_{PE}$									
$\leq 16 \text{ mm}^2$	0.67	0.71	0.75	0.80	0.86	0.93	1.00	1.11	1.20	1.33
25 mm <sup>2</sup>	0.85	0.91	0.96	1.02	1.10	1.19	1.28	1.42	1.54	1.71
35 mm <sup>2</sup>	1.06	1.13	1.20	1.27	1.37	1.48	1.59	1.77	1.91	2.13
>35 mm <sup>2</sup>	1.00	1.06	1.13	1.2	1.29	1.39	1.5	1.67	1.8	2.00

**Correction factor for neutral distributed in IT systems (for Table 3 only):** the value of the maximum protected length shall be multiplied by 0.58.

## 5 Protection of human beings

### TN system MPL by MCB

Table 2.1: Curve Z

CURVE	Z	Z	Z	Z	Z	Z	Z	Z	Z
In	$\leq 10$	13	16	20	25	32	40	50	63
I <sub>3</sub>	30	39	48	60	75	96	120	150	189
S	$S_{PE}$								
1.5	1.5	173	133	108	86	69	54	43	
2.5	2.5	288	221	180	144	115	90	72	58
4	4	461	354	288	231	185	144	115	92
6	6	692	532	432	346	277	216	173	138
10	10	1153	886	721	577	461	360	288	231
16	16	1845	1419	1153	923	738	577	461	369
25	16	2250	1730	1406	1125	900	703	563	450

Table 2.2: Curve B

CURVE	B	B	B	B	B	B	B	B	B	B	B	B	B
In	$\leq 6$	8	10	13	16	20	25	32	40	50	63	80	100
I <sub>3</sub>	30	40	50	65	80	100	125	160	200	250	315	400	500
S	$S_{PE}$												
1.5	1.5	173	130	104	80	65	52	42	32	26			
2.5	2.5	288	216	173	133	108	86	69	54	43	35	27	
4	4	461	346	277	213	173	138	111	86	69	55	44	35
6	6	692	519	415	319	259	208	166	130	104	83	66	52
10	10	1153	865	692	532	432	346	277	216	173	138	110	86
16	16	1845	1384	1107	852	692	554	443	346	277	221	176	138
25	16	2250	1688	1350	1039	844	675	540	422	338	270	214	169
35	16											190	152

Table 2.3: Curve C

CURVE	C	C	C	C	C	C	C	C	C	C	C	C	C	C
In	$\leq 3$	4	6	8	10	13	16	20	25	32	40	50	63	80
I <sub>3</sub>	30	40	60	80	100	130	160	200	250	320	400	500	630	800
S	$S_{PE}$													
1.5	1.5	173	130	86	65	52	40	32	26	21	16	13		
2.5	2.5	288	216	144	108	86	67	54	43	35	27	22	17	14
4	4	461	346	231	173	138	106	86	69	55	43	35	28	22
6	6	692	519	346	259	208	160	130	104	83	65	52	42	33
10	10	1153	865	577	432	346	266	216	173	138	108	86	69	55
16	16	1845	1384	923	692	554	426	346	277	221	173	138	111	88
25	16	2250	1688	1125	844	675	519	422	338	270	211	169	135	107
35	16												95	76

## 5 Protection of human beings

**TN system MPL  
by MCB****Table 2.4: Curve K**

<b>CURVE</b>	<b>K</b>	<b>K</b>	<b>K</b>	<b>K</b>	<b>K</b>	<b>K</b>	<b>K</b>	<b>K</b>	<b>K</b>	<b>K</b>	<b>K</b>	<b>K</b>	<b>K</b>	<b>K</b>	<b>K</b>	<b>K</b>	<b>K</b>	<b>K</b>	<b>K</b>	<b>K</b>	<b>K</b>	<b>K</b>	<b>K</b>	<b>K</b>	<b>K</b>	<b>K</b>
In	≤2	≤3	4	4.2	5.8	6	8	10	11	13	15	16	20	25	26	32	37	40	41	45	50	63				
I <sub>3</sub>	28	42	56	59	81	84	112	140	154	182	210	224	280	350	364	448	518	560	574	630	700	882				
<b>S</b>	<b>S<sub>PE</sub></b>																									
1.5	1.5	185	123	92	88	64	62	46	37	34	28	25	23	18	15	14	12	10	9							
2.5	2.5	308	205	154	146	106	103	77	62	56	47	41	38	31	25	24	19	17	15	15	14					
4	4	492	328	246	234	170	164	123	98	89	76	66	62	49	39	38	31	27	25	24	22	20	16			
6	6	738	492	369	350	255	246	185	148	134	114	98	92	74	59	57	46	40	37	36	33	30	23			
10	10	1231	820	615	584	425	410	308	246	224	189	164	154	123	98	95	77	67	62	60	55	49	39			
16	16	1969	1313	984	934	681	656	492	394	358	303	263	246	197	158	151	123	106	98	96	88	79	63			
25	16	2401	1601	1201	1140	830	800	600	480	437	369	320	300	240	192	185	150	130	120	117	107	96	76			

**Table 2.5: Curve D**

<b>CURVE</b>	<b>D</b>	<b>D</b>	<b>D</b>	<b>D</b>	<b>D</b>	<b>D</b>	<b>D</b>	<b>D</b>	<b>D</b>	<b>D</b>	<b>D</b>	<b>D</b>	<b>D</b>	<b>D</b>	<b>D</b>	<b>D</b>	<b>D</b>	<b>D</b>	<b>D</b>
In	≤2	3	4	6	8	10	13	16	20	25	32	40	50	63	80	100			
I <sub>3</sub>	40	60	80	120	160	200	260	320	400	500	640	800	1000	1260	1600	2000			
<b>S</b>	<b>S<sub>PE</sub></b>																		
1.5	1.5	130	86	65	43	32	26	20	16	13	10	8	6						
2.5	2.5	216	144	108	72	54	43	33	27	22	17	14	11	9	7				
4	4	346	231	173	115	86	69	53	43	35	28	22	17	14	11	9	7		
6	6	519	346	259	173	130	104	80	65	52	42	32	26	21	16	13	10		
10	10	865	577	432	288	216	173	133	108	86	69	54	43	35	27	22	17		
16	16	1384	923	692	461	346	277	213	173	138	111	86	69	55	44	35	28		
25	16	1688	1125	844	563	422	338	260	211	169	135	105	84	68	54	42	34		
35	16															47	38		

## 5 Protection of human beings

**TN system MPL  
by MCCB****Table 2.6: TmaxT1 TMD**

	<b>T1</b>	<b>T1</b>	<b>T1</b>	<b>T1</b>	<b>T1</b>	<b>T1</b>	<b>T1</b>
In	≤50	≤50	63	80	100	125	160
I <sub>3</sub>	500 A	630 A	10 In	10 In	10 In	10 In	10 In
<b>S</b>	<b>S<sub>PE</sub></b>						
1.5	1.5	6					
2.5	2.5	10					
4	4	15	12	12	10	8	6
6	6	23	18	18	14	12	9
10	10	38	31	31	24	19	15
16	16	62	49	49	38	31	25
25	16	75	60	60	47	38	30
35	16	84	67	67	53	42	34
50	25	128	102	102	80	64	51
70	35	179	142	142	112	90	72
95	50	252	200	200	157	126	101

**Table 2.7: Tmax T2 TMD**

	<b>T2</b>	<b>T2</b>	<b>T2</b>	<b>T2</b>	<b>T2</b>	<b>T2</b>	<b>T2</b>	<b>T2</b>	<b>T2</b>	<b>T2</b>	<b>T2</b>	<b>T2</b>	<b>T2</b>	<b>T2</b>	<b>T2</b>	<b>T2</b>	<b>T2</b>	<b>T2</b>
In	1.6	2	2.5	3.2	4	5	6.3	8	10	12.5	16+50	63	80	100	125	160		
I <sub>3</sub>	10 In	10 In	10 In	10 In	10 In	10 In	10 In	10 In	10 In	10 In	10 In	500 A	10 In	10 In	10 In	10 In		
<b>S</b>	<b>S<sub>PE</sub></b>																	
1.5	1.5	246	197	157	123	98	79	62	49	39	31	8						
2.5	2.5	410	328	262	205	164	131	104	82	66	52	13						
4	4	655	524	419	328	262	210	166	131	105	84	21	17	13	10	8		
6	6	983	786	629	491	393	315	250	197	157	126	31	25	20	16	13		
10	10	1638	1311	1048	819	655	524	416	328	262	210	52	42	33	26	21		
16	16	2621	2097	1677	1311	1048	839	666	524	419	335	84	67	52	42	34		
25	16	1598 1279 1023 812					639	511	409	102	81	64	51	41	32			
35	16	1151 914					720	576	460	115	91	72	58	46	36			
50	25	1092 874					699	175	139	109	87	70	55					
70	35	979					245	194	153	122	98	76						
95	50	343 273 215 172 137					107											
120	70	417 331 261 209 167					130											
150	95	518 411 324 259 207					162											
185	95	526 418 329 263 211					165											

## 5 Protection of human beings

TN system MPL  
by MCCB

Table 2.8: Tmax T3 TMD

		T3	T3	T3	T3	T3	T3	T3
In		63	80	100	125	160	200	250
I <sub>3</sub>		10 In	10 In	10 In	10 In	10 In	10 In	10 In
S	S <sub>PE</sub>							
4	4	17	13	10	8			
6	6	25	20	16	13	10	8	
10	10	42	33	26	21	16	13	10
16	16	67	52	42	34	26	21	17
25	16	81	64	51	41	32	26	20
35	16	91	72	58	46	36	29	23
50	25	139	109	87	70	55	44	35
70	35	194	153	122	98	76	61	49
95	50	273	215	172	137	107	86	69
120	70	331	261	209	167	130	104	83
150	95	411	324	259	207	162	130	104
185	95	418	329	263	211	165	132	105
240	120	499	393	315	252	197	157	126

Table 2.9: Tmax T4 TMD/TMA

		T4	T4	T4	T4	T4	T4	T4	T4	
In		20	32	50	80	100	125	160	200	250
I <sub>3</sub>		320 A	10 In	10 In	5...10 In	5...10 In	5...10 In	5...10 In	5...10 In	5...10 In
S	S <sub>PE</sub>									
1.5	1.5	14	14	9	11...5	9...4	7...3	5...3	4...2	3...2
2.5	2.5	23	23	14	18...9	14...7	12...6	9...5	7...4	6...3
4	4	36	36	23	29...14	23...12	18...9	14...7	12...6	9...5
6	6	54	54	35	43...22	35...17	28...14	22...11	17...9	14...7
10	10	90	90	58	72...36	58...29	46...23	36...18	29...14	23...12
16	16	144	144	92	115...58	92...46	74...37	58...29	46...23	37...18
25	16	176	176	113	141...70	113...56	90...45	70...35	56...28	45...23
35	16	198	198	127	158...79	127...63	101...51	79...40	63...32	51...25
50	25	300	300	192	240...120	192...96	154...77	120...60	96...48	77...38
70	35	420	420	269	336...168	269...135	215...108	168...84	135...67	108...54
95	50	590	590	378	472...236	378...189	302...151	236...118	189...94	151...76
120	70	717	717	459	574...287	459...229	367...184	287...143	229...115	184...92
150	95	891	891	570	713...356	570...285	456...228	356...178	285...143	228...114
185	95	905	905	579	724...362	579...290	463...232	362...181	290...145	232...116
240	120	1081	1081	692	865...432	692...346	554...277	432...216	346...173	277...138
300	150	1297	1297	830	1038...519	830...415	664...332	519...259	415...208	332...166

## 5 Protection of human beings

TN system MPL  
by MCCB

Table 2.10: Tmax T5-T6 TMA

		T5	T5	T5	T6	T6
In		320	400	500	630	800
I <sub>3</sub>		5...10 In	5...10 In	5...10 In	5...10 In	5...10 In
S	S <sub>PE</sub>					
1,5	1,5	3...1	2...1	2...1	1...1	1...1
2,5	2,5	5...2	4...2	3...1	2...1	2...1
4	4	7...4	6...3	5...2	4...2	3...1
6	6	11...5	9...4	7...3	5...3	4...2
10	10	18...9	14...7	12...6	9...5	7...4
16	16	29...14	23...12	18...9	15...7	12...6
25	16	35...18	28...14	23...11	18...9	14...7
35	16	40...20	32...16	25...13	20...10	16...8
50	25	60...30	48...24	38...19	31...15	24...12
70	35	84...42	67...34	54...27	43...21	34...17
95	50	118...59	94...47	76...38	60...30	47...24
120	70	143...72	115...57	92...46	73...36	57...29
150	95	178...89	143...71	114...57	91...45	71...36
185	95	181...90	145...72	116...58	92...46	72...36
240	120	216...108	173...86	138...69	110...55	86...43
300	150	259...130	208...104	166...83	132...66	104...52

Table 2.11: Tmax T2 with PR221 DS-LS

		T2	T2	T2	T2	T2
In		10	25	63	100	160
I <sub>3</sub>		5.5 In	5.5 In	5.5 In	5.5 In	5.5 In
S	S <sub>PE</sub>					
1.5	1.5	79	31	12		
2.5	2.5	131	52	21		
4	4	210	84	33	21	
6	6	315	126	50	31	20
10	10	524	210	83	52	33
16	16	839	335	133	84	52
25	16	1023	409	162	102	64
35	16	1151	460	183	115	72
50	25	1747	699	277	175	109
70	35	2446	979	388	245	153
95	50	3434	1374	545	343	215
120	70	4172	1669	662	417	261
150	95	5183	2073	823	518	324
185	95	5265	2106	836	526	329

Note: if the setting of function I is different from the reference value (5.5), the value of the MPL shall be multiplied by the ratio between the reference value and the set value.

## 5 Protection of human beings

TN system MPL  
by MCCB

Table 2.12: Tmax T4-T5-T6 with PR221 - PR222 - PR223  
Tmax T7 with PR231 -PR232 - PR331 - PR332

	T4	T4	T4	T4	T5	T5	T5	T6	T6	T6	T7	T7	T7	T7	
In	100	160	250	320	320	400	630	630	800	1000	800	1000	1250	1600	
I <sub>3</sub>	6.5 In	6.5 In	6.5 In	6.5 In	6.5 In	6.5 In	6.5 In	6.5 In	6.5 In	6.5 In	6.5 In	6.5 In	6.5 In	6.5 In	
S	S <sub>PE</sub>														
1,5	1,5														
2,5	2,5														
4	4														
6	6	29	18												
10	10	48	30	19											
16	16	77	48	31	24	24	19								
25	16	94	59	38	30	30	24	15							
35	16	106	66	43	33	33	27	17							
50	25	161	101	65	50	50	40	26	20	20					
70	35	226	141	90	71	71	56	36	36	28	23	28	23	18	14
95	50	317	198	127	99	99	79	50	50	40	32	40	32	25	20
120	70	385	241	154	120	120	96	61	61	48	39	48	39	31	24
150	95	478	299	191	150	150	120	76	76	60	48	60	48	38	30
185	95	486	304	194	152	152	121	77	77	61	49	61	49	39	30
240	120	581	363	232	181	181	145	92	92	73	58	73	58	46	36
300	150	697	435	279	218	218	174	111	111	87	70	87	70	55	43

Note: if the setting of function I is different from the reference value (6.5), the value of the MPL shall be multiplied by the ratio between the reference value and the set value.

Table 2.13: SACE Isomax S7 with PR211- PR212

	S7	S7	S7
In	1000	1250	1600
I <sub>3</sub>	6 In	6 In	6 In
S	S <sub>PE</sub>		
2.5	2.5		
4	4		
6	6		
10	10		
16	16		
25	16		
35	16		
50	25		
70	35	22	18
95	50	31	25
120	70	38	31
150	95	48	38
185	95	48	39
240	120	58	46
300	150	69	55

Note: if the setting of function S or I is different from the reference value (6), the MPL value shall be multiplied by the ratio between the reference value and the set value. Besides, using function S the MPL shall be multiplied by 1.1.

## 5 Protection of human beings

IT system MPL  
by MCB

Table 3.1: Curve Z

CURVE	Z	Z	Z	Z	Z	Z	Z	Z	Z	Z
In	≤8	10	13	16	20	25	32	40	50	63
I <sub>3</sub>	30	30	39	48	60	75	96	120	150	189
S	S <sub>PE</sub>									
1.5	1.5	150	150	115	94	75	60	47	37	
2.5	2.5	250	250	192	156	125	100	78	62	50
4	4	400	400	307	250	200	160	125	100	80
6	6	599	599	461	375	300	240	187	150	120
10	10	999	999	768	624	499	400	312	250	200
16	16	1598	1598	1229	999	799	639	499	400	320
25	16	1949	1949	1499	1218	974	780	609	487	390

Table 3.2: Curve B

CURVE	B	B	B	B	B	B	B	B	B	B	B	B	B	
In	≤6	8	10	13	16	20	25	32	40	50	63	80	100	
I <sub>3</sub>	30	40	50	65	80	100	125	160	200	250	315	400	500	
S	S <sub>PE</sub>													
1.5	1.5	150	112	90	69	56	45	36	28	22				
2.5	2.5	250	187	150	115	94	75	60	47	37	30	24		
4	4	400	300	240	184	150	120	96	75	60	48	38	30	
6	6	599	449	360	277	225	180	144	112	90	72	57	45	
10	10	999	749	599	461	375	300	240	187	150	120	95	75	
16	16	1598	1199	959	738	599	479	384	300	240	192	152	120	
25	16	1949	1462	1169	899	731	585	468	365	292	234	186	146	
35	16												165	132

Table 3.3: Curve C

CURVE	C	C	C	C	C	C	C	C	C	C	C	C	C	C	C
In	≤3	4	6	8	10	13	16	20	25	32	40	50	63	80	100
I <sub>3</sub>	30	40	60	80	100	130	160	200	250	320	400	500	630	800	1000
S	S <sub>PE</sub>														
1.5	1.5	150	112	75	56	45	35	28	22	18	14	11			
2.5	2.5	250	187	125	94	75	58	47	37	30	23	19	15	12	
4	4	400	300	200	150	120	92	75	60	48	37	30	24	19	15
6	6	599	449	300	225	180	138	112	90	72	56	45	36	29	22
10	10	999	749	499	375	300	230	187	150	120	94	75	60	48	37
16	16	1598	1199	799	599	479	369	300	240	192	150	120	96	76	60
25	16	1949	1462	974	731	585	450	365	292	234	183	146	117	93	73
35	16												82	66	53

## 5 Protection of human beings

IT system MPL  
by MCB

Table 3.4: Curve K

CURVE	K	K	K	K	K	K	K	K	K	K	K	K	K	K	K	K	K	K	K	K	K	K	
In	≤2	≤3	4	4.2	5.8	6	8	10	11	13	15	16	20	25	26	32	37	40	41	45	50	63	
I <sub>3</sub>	28	42	56	59	81	84	112	140	154	182	210	224	280	350	364	448	518	560	574	630	700	882	
S	S <sub>PE</sub>																						
1.5	1.5	161	107	80	76	55	54	40	32	29	25	21	20	16	13	12	10	9	8				
2.5	2.5	268	178	134	127	92	89	67	54	49	41	36	33	27	21	21	17	14	13	13	12		
4	4	428	285	214	204	148	143	107	86	78	66	57	54	43	34	33	27	23	21	21	19	17	14
6	6	642	428	321	306	221	214	161	128	117	99	86	80	64	51	49	40	35	32	31	29	26	20
10	10	1070	713	535	510	369	357	268	214	195	165	143	134	107	86	82	67	58	54	52	48	43	34
16	16	1712	1141	856	815	590	571	428	342	311	263	228	214	171	137	132	107	93	86	84	76	68	54
25	16	2088	1392	1044	994	720	696	522	418	380	321	278	261	209	167	161	130	113	104	102	93	84	66

Table 3.5: Curve D

CURVE	D	D	D	D	D	D	D	D	D	D	D	D	D	D	D	D	D	D	D	D	D	D	D			
In	≤2	3	4	6	8	10	13	16	20	25	32	40	50	63	80	100										
I <sub>3</sub>	40	60	80	120	160	200	260	320	400	500	640	800	1000	1260	1600	2000										
S	S <sub>PE</sub>																									
1.5	1.5	112	75	56	37	28	22	17	14	11	9	7	6													
2.5	2.5	187	125	94	62	47	37	29	23	19	15	12	9	7	6											
4	4	300	200	150	100	75	60	46	37	30	24	19	15	12	10	7	6									
6	6	449	300	225	150	112	90	69	56	45	36	28	22	18	14	11	9									
10	10	749	499	375	250	187	150	115	94	75	60	47	37	30	24	19	15									
16	16	1199	799	599	400	300	240	184	150	120	96	75	60	48	38	30	24									
25	16	1462	974	731	487	365	292	225	183	146	117	91	73	58	46	37	29									
35																		41	33							

## 5 Protection of human beings

IT system MPL  
by MCCB

Table 3.6: Tmax T1 TMD

	T1	T1	T1	T1	T1	T1	T1	
In	≤50	≤50	63	80	100	125	160	
I <sub>3</sub>	500 A	630 A	10 In	10 In	10 In	10 In	10 In	
S	S <sub>PE</sub>							
1.5	1.5	5						
2.5	2.5	8						
4	4	13	11	11	8	7	5	
6	6	20	16	16	12	10	8	6
10	10	33	26	26	21	17	13	10
16	16	53	42	42	33	27	21	17
25	16	65	52	52	41	32	26	20
35	16	73	58	58	46	37	29	23
50	25	111	88	88	69	55	44	35
70	35	155	123	123	97	78	62	49
95	50	218	173	173	136	109	87	68

Table 3.7: Tmax T2 TMD

	T2	T2	T2	T2	T2	T2	T2	T2	T2	T2	T2	T2	T2	T2	T2	T2	T2	T2	T2	T2			
In	1.6	2	2.5	3.2	4	5	6.3	8	10	12.5	16+50	63	80	100	125	160							
I <sub>3</sub>	10 In	10 In	10 In	10 In	10 In	10 In	10 In	10 In	10 In	10 In	500 A	10 In	10 In	10 In	10 In	10 In							
S	S <sub>PE</sub>																						
1.5	1.5	213	170	136	106	85	68	54	43	34	27	7											
2.5	2.5	355	284	227	177	142	113	90	71	57	45	11											
4	4	567	454	363	284	227	182	144	113	91	73	18	14	11	9	7							
6	6	851	681	545	426	340	272	216	170	136	109	27	22	17	14	11	9						
10	10	1419	1135	908	709	567	454	360	284	227	182	45	36	28	23	18	14						
16	16	2270	1816	1453	1135	908	726	576	454	363	291	73	58	45	36	29	23						
25	16				1384	1107	886	703	554	443	354	89	70	55	44	35	28						
35	16						997	791	623	498	399	100	79	62	50	40	31						
50	25								946	757	605	151	120	95	76	61	47						
70	35											847	212	168	132	106	85	66					
95	50												297	236	186	149	119	93					
120	70													361	287	226	181	145	113				
150	95														449	356	281	224	180	140			
185	95															456	362	285	228	182	142		



## 5 Protection of human beings

IT system MPL  
by MCCB

Table 3.8: Tmax T3 TMD

S	S <sub>PE</sub>	T3	T3	T3	T3	T3	T3	T3
		In	63	80	100	125	160	200
		10 In	10 In	10 In	10 In	10 In	10 In	10 In
4	4	14	11	9	7			
6	6	22	17	14	11	9	7	
10	10	36	28	23	18	14	11	9
16	16	58	45	36	29	23	18	15
25	16	70	55	44	35	28	22	18
35	16	79	62	50	40	31	25	20
50	25	120	95	76	61	47	38	30
70	35	168	132	106	85	66	53	42
95	50	236	186	149	119	93	74	59
120	70	287	226	181	145	113	90	72
150	95	356	281	224	180	140	112	90
185	95	362	285	228	182	142	114	91
240	120	432	340	272	218	170	136	109

Table 3.9: Tmax T4 TMD/TMA

S	S <sub>PE</sub>	T4	T4	T4	T4	T4	T4	T4	T4		
		In	20	32	50	80	100	125	160	200	250
		I <sub>3</sub>	320 A	10 In	10 In	5...10 In	5...10 In	5...10 In	5...10 In	5...10 In	5...10 In
1.5	1.5	12	12	7	9...5	7...4	6...3	5...2	4...2	3...1	
2.5	2.5	20	20	12	16...8	12...6	10...5	8...4	6...3	5...2	
4	4	31	31	20	25...12	20...10	16...8	12...6	10...5	8...4	
6	6	47	47	30	37...19	30...15	24...12	19...9	15...7	12...6	
10	10	78	78	50	62...31	50...25	40...20	31...16	25...12	20...10	
16	16	125	125	80	100...50	80...40	64...32	50...25	40...20	32...16	
25	16	152	152	97	122...61	97...49	78...39	61...30	49...24	39...19	
35	16	171	171	110	137...69	110...55	88...44	69...34	55...27	44...22	
50	25	260	260	166	208...104	166...83	133...67	104...52	83...42	67...33	
70	35	364	364	233	291...146	233...117	186...93	146...73	117...58	93...47	
95	50	511	511	327	409...204	327...164	262...131	204...102	164...82	131...65	
120	70	621	621	397	497...248	397...199	318...159	248...124	199...99	159...79	
150	95	772	772	494	617...309	494...247	395...198	309...154	247...123	198...99	
185	95	784	784	502	627...313	502...251	401...201	313...157	251...125	201...100	
240	120	936	936	599	749...375	599...300	479...240	375...187	300...150	240...120	
300	150	1124	1124	719	899...449	719...360	575...288	449...225	360...180	288...144	

## 5 Protection of human beings

IT system MPL  
by MCCB

Table 3.10: Tmax T5-T6 TMA

S	S <sub>PE</sub>	T5	T5	T5	T6	T6	
		In	320	400	500	630	800
		I <sub>3</sub>	5...10 In	5...10 In	5...10 In	5...10 In	5...10 In
1.5	1.5	2...1	2...1	1...1	1...1		
2.5	2.5	4...2	3...2	2...1	2...1	2...1	
4	4	6...3	5...2	4...2	3...2	2...1	
6	6	9...5	7...4	6...3	5...2	4...2	
10	10	16...8	12...6	10...5	8...4	6...3	
16	16	25...12	20...10	16...8	13...6	10...5	
25	16	30...15	24...12	19...10	15...8	12...6	
35	16	34...17	27...14	22...11	17...9	14...7	
50	25	52...26	42...21	33...17	26...13	21...10	
70	35	73...36	58...29	47...23	37...18	29...15	
95	50	102...51	82...41	65...33	52...26	41...20	
120	70	124...62	99...50	79...40	63...32	50...25	
150	95	154...77	123...62	99...49	78...39	62...31	
185	95	157...78	125...63	100...50	80...40	63...31	
240	120	187...94	150...75	120...60	95...48	75...37	
300	150	225...112	180...90	144...72	114...57	90...45	

Table 3.11: Tmax T2 with PR221 DS-LS

S	S <sub>PE</sub>	T2	T2	T2	T2	T2	
		In	10	25	63	100	160
		I <sub>3</sub>	5.5 In	5.5 In	5.5 In	5.5 In	5.5 In
1.5	1.5	68	27	11			
2.5	2.5	113	45	18			
4	4	182	73	29	18		
6	6	272	109	43	27	17	
10	10	454	182	72	45	28	
16	16	726	291	115	73	45	
25	16	886	354	141	89	55	
35	16	997	399	158	100	62	
50	25	1513	605	240	151	95	
70	35	2119	847	336	212	132	
95	50	2974	1190	472	297	186	
120	70	3613	1445	573	361	226	
150	95	4489	1796	713	449	281	
185	95	4559	1824	724	456	285	

Note: if the setting of function I is different from the reference value (5.5), the MPL value shall be multiplied by the ratio between the reference value and the set value.

## 5 Protection of human beings

IT system MPL by MCCB Table 3.12: Tmax T4-T5-T6 with PR221 - PR222 - PR223  
Tmax T7 with PR231-PR232-PR331-PR332

	T4	T4	T4	T4	T5	T5	T5	T6	T6	T6	T7	T7	T7	T7	
In	100	160	250	320	320	400	630	630	800	1000	800	1000	1250	1600	
I <sub>3</sub>	6.5 In	6.5 In	6.5 In	6.5 In	6.5 In	6.5 In	6.5 In	6.5 In	6.5 In	6.5 In	6.5 In	6.5 In	6.5 In	6.5 In	
S	S <sub>PE</sub>														
1.5	1.5														
2.5	2.5														
4	4														
6	6	25	16												
10	10	42	26	17											
16	16	67	42	27	21	21	17								
25	16	82	51	33	26	26	20	13	13						
35	16	92	58	37	29	29	23	15	15	12	12				
50	25	140	87	56	44	44	35	22	22	17	14	17			
70	35	196	122	78	61	61	49	31	31	24	20	24	19	16	12
95	50	275	172	110	86	86	69	44	44	34	27	34	27	22	17
120	70	333	208	133	104	104	83	53	53	42	33	42	33	26	21
150	95	414	259	166	129	129	104	66	66	52	41	52	41	33	26
185	95	421	263	168	132	132	105	67	67	53	42	53	42	33	26
240	120	503	314	201	157	157	126	80	80	63	50	63	50	40	31
300	150	603	377	241	189	189	151	96	96	75	60	75	60	48	37

Note: if the setting of function I is different from the reference value (6.5), the value of the MPL shall be multiplied by the ratio between the reference value and the set value.

## 5 Protection of human beings

IT system MPL by MCCB Table 3.13: SACE Isomax S7 with PR211-212

	S7	S7	S7	
In	1000	1250	1600	
I <sub>3</sub>	6 In	6 In	6 In	
S	S <sub>PE</sub>			
2.5	2.5			
4	4			
6	6			
10	10			
16	16			
25	16			
35	16			
50	25			
70	35	19	16	12
95	50	27	22	17
120	70	33	26	21
150	95	41	33	26
185	95	42	33	26
240	120	50	40	31
300	150	60	48	37

Note: if the setting of function S or I is different from the reference value (6), the MPL value shall be multiplied by the ratio between the reference value and the set value. Besides, using function S, the MPL shall be multiplied by 1.1.

## 6 Calculation of short-circuit current

### 6.1 General aspects

A short-circuit is a fault of negligible impedance between live conductors having a difference in potential under normal operating conditions.

### 6.2 Fault typologies

In a three-phase circuit the following types of fault may occur:

- three-phase fault;
- two-phase fault;
- phase to neutral fault;
- phase to PE fault.

In the formulas, the following symbols are used:

- $I_k$  short-circuit current;
- $U_r$  rated voltage;
- $Z_L$  phase conductor impedance;
- $Z_N$  neutral conductor impedance;
- $Z_{PE}$  protective conductor impedance.

The following table briefly shows the type of fault and the relationships between the value of the short-circuit current for a symmetrical fault (three phase) and the short-circuit current for asymmetrical faults (two phase and single phase) in case of faults far from generators.

#### Three-phase fault

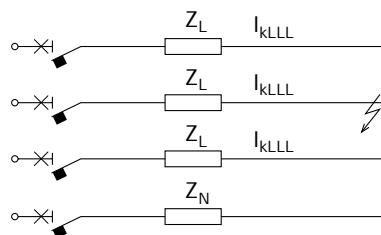

$$I_{kLLL} = \frac{U_r}{\sqrt{3} Z_L}$$

where

$$Z_L = \sqrt{R_L^2 + X_L^2}$$

#### Two-phase fault

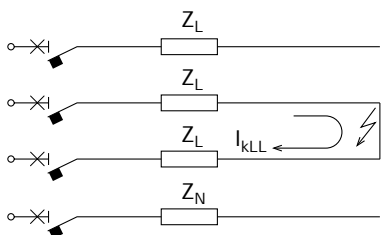

$$I_{kLL} = \frac{U_r}{2Z_L} = \frac{\sqrt{3}}{2} I_{kLLL} = 0.87 I_{kLLL}$$

## 6 Calculation of short-circuit current

#### Phase to neutral fault

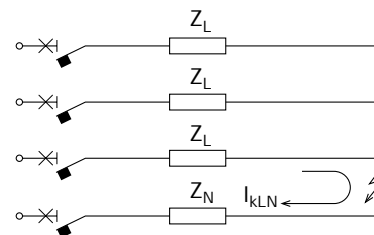

$$I_{kLN} = \frac{U_r}{\sqrt{3}(Z_L + Z_N)}$$

If  $Z_L = Z_N$  (cross section of neutral conductor equal to the phase conductor one):

$$I_{kLN} = \frac{U_r}{\sqrt{3}(Z_L + Z_N)} = \frac{U_r}{\sqrt{3}(2Z_L)} = 0.5 I_{kLLL}$$

If  $Z_N = 2Z_L$  (cross section of neutral conductor half the phase conductor one):

$$I_{kLN} = \frac{U_r}{\sqrt{3}(Z_L + Z_N)} = \frac{U_r}{\sqrt{3}(3Z_L)} = 0.33 I_{kLLL}$$

If  $Z_N \equiv 0$  limit condition:

$$I_{kLN} = \frac{U_r}{\sqrt{3}(Z_L + Z_N)} = \frac{U_r}{\sqrt{3}(Z_L)} = I_{kLLL}$$

#### Phase to PE fault

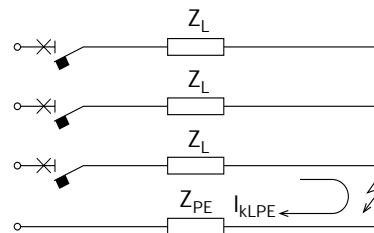

$$I_{kLPE} = \frac{U_r}{\sqrt{3}(Z_L + Z_{PE})}$$

If  $Z_L = Z_{PE}$  (cross section of protective conductor equal to the phase conductor one):

$$I_{kLPE} = \frac{U_r}{\sqrt{3}(Z_L + Z_{PE})} = \frac{U_r}{\sqrt{3}(2Z_L)} = 0.5 I_{kLLL}$$

If  $Z_{PE} = 2Z_L$  (cross section of protective conductor half to the phase conductor one):

$$I_{kLPE} = \frac{U_r}{\sqrt{3}(Z_L + Z_{PE})} = \frac{U_r}{\sqrt{3}(3Z_L)} = 0.33 I_{kLLL}$$

If  $Z_{PE} \equiv 0$  limit condition:

$$I_{kLPE} = \frac{U_r}{\sqrt{3}(Z_L + Z_{PE})} = \frac{U_r}{\sqrt{3}(Z_L)} = I_{kLLL}$$

The following table allows the approximate value of a short-circuit current to be found quickly.

Note	Three-phase short-circuit	Two-phase short-circuit	Phase to neutral short-circuit	Phase to PE short-circuit (TN system)
	$I_{kLLL}$	$I_{kLL}$	$I_{kLN}$	$I_{kLPE}$
$I_{kLLL}$	-	$I_{kLL} = 0.87 I_{kLLL}$	$I_{LN} = 0.5 I_{kLLL} (Z_L = Z_N)$ $I_{LN} = 0.33 I_{kLLL} (Z_L = 0.5 Z_N)$ $I_{LN} = I_{kLLL} (Z_N \equiv 0)$	$I_{LPE} = 0.5 I_{kLLL} (Z_L = Z_{PE})$ $I_{LPE} = 0.33 I_{kLLL} (Z_L = 0.5 Z_{PE})$ $I_{LPE} = I_{kLLL} (Z_{PE} \equiv 0)$
$I_{kLL}$	$I_{kLLL} = 1.16 I_{kLL}$	-	$I_{kLN} = 0.58 I_{kLL} (Z_L = Z_N)$ $I_{kLN} = 0.38 I_{kLL} (Z_L = 0.5 Z_N)$ $I_{kLN} = 1.16 I_{kLL} (Z_N \equiv 0)$	$I_{kLPE} = 0.58 I_{kLL} (Z_L = Z_{PE})$ $I_{kLPE} = 0.38 I_{kLL} (Z_L = 0.5 Z_{PE})$ $I_{kLPE} = 1.16 I_{kLL} (Z_{PE} \equiv 0)$
$I_{kLN}$	$I_{kLLL} = 2 I_{kLN} (Z_L = Z_N)$ $I_{kLLL} = 3 I_{kLN} (Z_L = 0.5 Z_N)$ $I_{kLLL} = I_{kLN} (Z_N \equiv 0)$	$I_{kLL} = 1.73 I_{kLN} (Z_L = Z_N)$ $I_{kLL} = 2.6 I_{kLN} (Z_L = 0.5 Z_N)$ $I_{kLL} = 0.87 I_{kLN} (Z_N \equiv 0)$	-	-

## 6 Calculation of short-circuit current

### 6.3 Determination of the short-circuit current: "short-circuit power method"

The short-circuit current can be determined by using the "short-circuit power method". This method allows the determination of the approximate short-circuit current at a point in an installation in a simple way; the resultant value is generally acceptable. However, this method is not conservative and gives more accurate values, the more similar the power factors of the considered components are (network, generators, transformers, motors and large section cables etc.). The "short-circuit power method" calculates the short-circuit current  $I_k$  based on the formula:

$$\text{Three-phase short-circuit} \quad I_k = \frac{S_k}{\sqrt{3} \cdot U_r}$$

$$\text{Two-phase short-circuit} \quad I_k = \frac{S_k}{2 \cdot U_r}$$

where:

- $S_k$  is the short-circuit apparent power seen at the point of the fault;
- $U_r$  is the rated voltage.

To determine the short-circuit apparent power  $S_k$ , all the elements of the network shall be taken into account, which may be:

- elements which contribute to the short-circuit current: network, generators, motors;
- elements which limit the value of the short-circuit current: conductors and transformers.

The procedure for the calculation of the short-circuit current involves the following steps:

1. calculation of the short-circuit power for the different elements of the installation;
2. calculation of the short-circuit power at the fault point;
3. calculation of the short-circuit current.

#### 6.3.1 Calculation of the short-circuit power for the different elements of the installation

The short-circuit apparent power  $S_k$  shall be determined for all the components which are part of the installation:

##### Network

An electrical network is considered to include everything upstream of the point of energy supply.

## 6 Calculation of short-circuit current

Generally, the energy distribution authority supplies the short-circuit apparent power ( $S_{knet}$ ) value at the point of energy supply. However, if the value of the short-circuit current  $I_{knet}$  is known, the value of the power can be obtained by using, for three-phase systems, the following formula:

$$S_{knet} = \sqrt{3} U_r I_{knet}$$

where  $U_r$  is the rated voltage at the point of energy supply.

If the aforementioned data are not available, the values for  $S_{knet}$  given in the following table can be taken as reference values:

Net voltage $U_r$ [kV]	Short-circuit power $S_{knet}$ [MVA]
$U_p$ to 20	500
$U_p$ to 32	750
$U_p$ to 63	1000

##### Generator

The short-circuit power is obtained from:

$$S_{kgen} = \frac{S_r \cdot 100}{X_{d\%}^*}$$

where  $X_{d\%}^*$  is the percentage value of the subtransient reactance ( $X_{d'}^*$ ) or of the transient reactance ( $X_d'$ ) or of the synchronous reactance ( $X_d$ ), according to the instant in which the value of the short-circuit power is to be evaluated.

In general, the reactances are expressed in percentages of the rated impedance of the generator ( $Z_d$ ) given by:

$$Z_d = \frac{U_r^2}{S_r}$$

where  $U_r$  and  $S_r$  are the rated voltage and power of the generator.

Typical values can be:

- $X_{d'}^*$  from 10 % to 20 %;
- $X_d'$  from 15 % to 40 %;
- $X_d$  from 80 % to 300 %.

Normally, the worst case is considered, that being the subtransient reactance. The following table gives the approximate values of the short-circuit power of generators ( $X_{d'}^* = 12.5\%$ ):

$S_r$ [kVA]	50	63	125	160	200	250	320	400	500	630	800	1000	1250	1600	2000	2500	3200	4000
$S_{kgen}$ [MVA]	0.4	0.5	1.0	1.3	1.6	2.0	2.6	3.2	4.0	5.0	6.4	8.0	10.0	12.8	16.0	20.0	25.6	32.0

## 6 Calculation of short-circuit current

### Asynchronous three-phase motors

Under short-circuit conditions, electric motors contribute to the fault for a brief period (5-6 periods).

The power can be calculated according to the short-circuit current of the motor ( $I_k$ ), by using the following expression:

$$S_{k\text{mot}} = \sqrt{3} \cdot U_r \cdot I_k$$

Typical values are:

$$S_{k\text{mot}} = 5+7 S_{r\text{mot}}$$

( $I_k$  is about 5+7  $I_{r\text{mot}}$ : 5 for motors of small size, and 7 for larger motors).

### Transformers

The short-circuit power of a transformer ( $S_{k\text{trafo}}$ ) can be calculated by using the following formula:

$$S_{k\text{trafo}} = \frac{100}{u_k \%} \cdot S_r$$

The following table gives the approximate values of the short-circuit power of transformers:

$S_r$ [kVA]	50	63	125	160	200	250	320	400	500	630	800	1000	1250	1600	2000	2500	3200	4000
$u_k$ %	4	4	4	4	4	4	4	4	4	4	5	5	5	6	6	6	6	6
$S_{k\text{trafo}}$ [MVA]	1.3	1.6	3.1	4	5	6.3	8	10	12.5	15.8	16	20	25	26.7	33.3			

### Cables

A good approximation of the short-circuit power of cables is:

$$S_{k\text{cable}} = \frac{U_r^2}{Z_c}$$

where the impedance of the cable ( $Z_c$ ) is:

$$I_{kLL} = \frac{U_r}{\sqrt{3} Z_L}$$

where

$$Z_L = \sqrt{R_L^2 + X_L^2}$$

The following table gives the approximate values of the short-circuit power of cables, at 50 and 60 Hz, according to the supply voltage (cable length = 10 m):

## 6 Calculation of short-circuit current

S [mm <sup>2</sup> ]	230 [V] 400 [V] 440 [V] 500 [V] 690 [V]					230 [V] 400 [V] 440 [V] 500 [V] 690 [V]				
	$S_{k\text{cable}}$ [MVA] @50 Hz					$S_{k\text{cable}}$ [MVA] @60 Hz				
1.5	0.44	1.32	1.60	2.07	3.94	0.44	1.32	1.60	2.07	3.94
2.5	0.73	2.20	2.66	3.44	6.55	0.73	2.20	2.66	3.44	6.55
4	1.16	3.52	4.26	5.50	10.47	1.16	3.52	4.26	5.50	10.47
6	1.75	5.29	6.40	8.26	15.74	1.75	5.29	6.40	8.26	15.73
10	2.9	8.8	10.6	13.8	26.2	2.9	8.8	10.6	13.7	26.2
16	4.6	14.0	16.9	21.8	41.5	4.6	13.9	16.9	21.8	41.5
25	7.2	21.9	26.5	34.2	65.2	7.2	21.9	26.4	34.1	65.0
35	10.0	30.2	36.6	47.3	90.0	10.0	30.1	36.4	47.0	89.6
50	13.4	40.6	49.1	63.4	120.8	13.3	40.2	48.7	62.9	119.8
70	19.1	57.6	69.8	90.1	171.5	18.8	56.7	68.7	88.7	168.8
95	25.5	77.2	93.4	120.6	229.7	24.8	75.0	90.7	117.2	223.1
120	31.2	94.2	114.0	147.3	280.4	29.9	90.5	109.5	141.5	269.4
150	36.2	109.6	132.6	171.2	326.0	34.3	103.8	125.6	162.2	308.8
185	42.5	128.5	155.5	200.8	382.3	39.5	119.5	144.6	186.7	355.6
240	49.1	148.4	179.5	231.8	441.5	44.5	134.7	163.0	210.4	400.7
300	54.2	164.0	198.4	256.2	488.0	48.3	146.1	176.8	228.3	434.7

With  $n$  cables in parallel, it is necessary to multiply the value given in the table by  $n$ . If the length of the cable ( $L_{\text{act}}$ ) is other than 10 m, it is necessary to multiply the value given in the table by the following coefficient:

$$\frac{10}{L_{\text{act}}}$$

### 6.3.2 Calculation of the short-circuit power at the fault point

The rule for the determination of the short-circuit power at a point in the installation, according to the short-circuit power of the various elements of the circuit, is analogue to that relevant to the calculation of the equivalent admittance. In particular:

- the power of elements in series is equal to the inverse of the sum of the inverses of the single powers (as for the parallel of impedances);

$$S_k = \frac{1}{\sum \frac{1}{S_i}}$$

- the short-circuit power of elements in parallel is equal to the sum of the single short-circuit powers (as for the series of impedances).

$$S_k = \sum S_i$$

The elements of the circuit are considered to be in series or parallel, seeing the circuit from the fault point.

In the case of different branches in parallel, the distribution of the current between the different branches shall be calculated once the short-circuit current at the fault point has been calculated. This must be done to ensure the correct choice of protection devices installed in the branches.

## 6 Calculation of short-circuit current

### 6.3.3 Calculation of the short-circuit current

To determine the short-circuit current in an installation, both the fault point as well as the configuration of the system which maximize the short-circuit current involving the device shall be considered. If appropriate, the contribution of the motors shall be taken into account.

For example, in the case detailed below, for circuit-breaker CB1, the worst condition occurs when the fault is right upstream of the circuit-breaker itself. To determine the breaking capacity of the circuit-breaker, the contribution of two transformers in parallel must be considered.

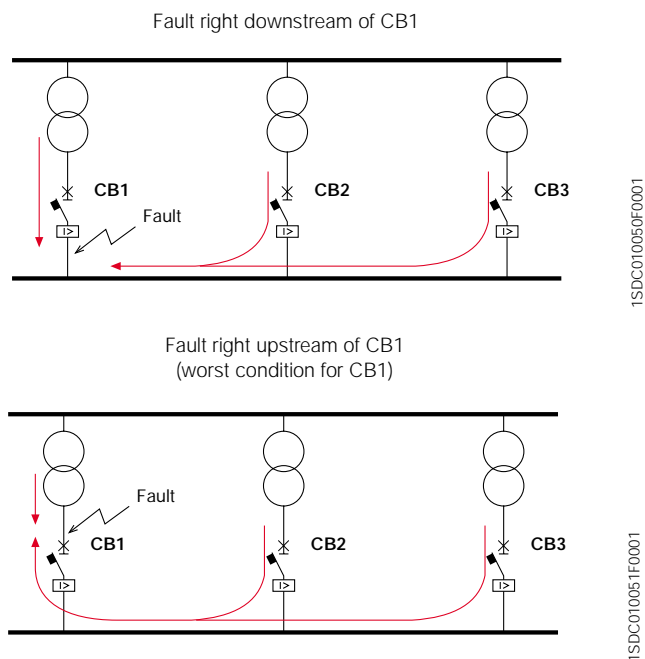

Once the short-circuit power equivalent at the fault point has been determined, the short-circuit current can be calculated by using the following formula:

Three-phase short-circuit 
$$I_k = \frac{S_k}{\sqrt{3} \cdot U_r}$$

Two-phase short-circuit 
$$I_k = \frac{S_k}{2 \cdot U_r}$$

## 6 Calculation of short-circuit current

As a first approximation, by using the following graph, it is possible to evaluate the three-phase short-circuit current downstream of an object with short-circuit power ( $S_{kEL}$ ) known: corresponding to this value, knowing the short-circuit power upstream of the object ( $S_{kUP}$ ), the value of  $I_k$  can be read on the y-axis, expressed in kA, at 400 V.

**Figure 1: Chart for the calculation of the three-phase short-circuit current at 400 V**

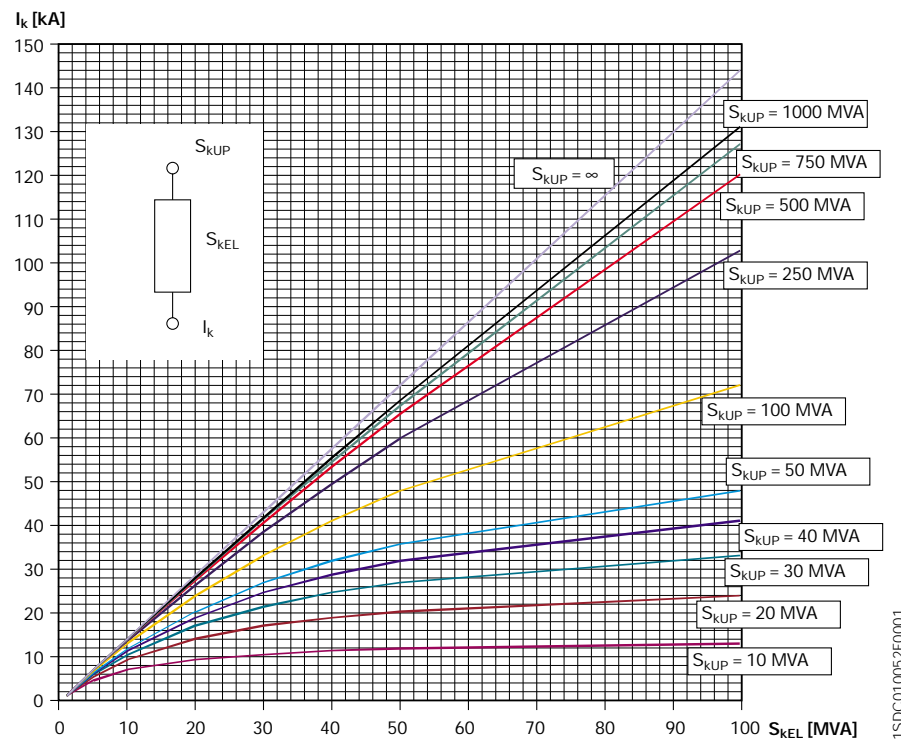

## 6 Calculation of short-circuit current

### 6.3.4 Examples

The following examples demonstrate the calculation of the short-circuit current in some different types of installation.

#### Example 1

Upstream network:  $U_r = 20000 \text{ V}$   
 $S_{knet} = 500 \text{ MVA}$

Transformer:  $S_r = 1600 \text{ kVA}$   
 $u_k\% = 6\%$   
 $U_{1r} / U_{2r} = 20000/400$

Motor:  $P_r = 220 \text{ kW}$   
 $I_{kmot}/I_r = 6.6$   
 $\cos\phi_r = 0.9$   
 $\eta = 0.917$

Generic load:  $I_{rL} = 1443.4 \text{ A}$   
 $\cos\phi_r = 0.9$

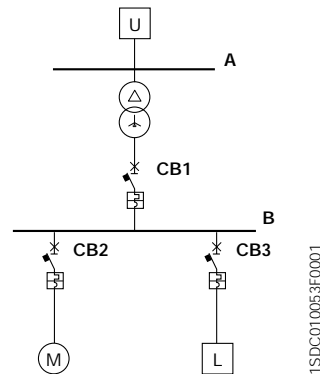

#### Calculation of the short-circuit power of different elements

Network:  $S_{knet} = 500 \text{ MVA}$

Transformer:  $S_{ktrafo} = \frac{100}{u_k\%} \cdot S_r = 26.7 \text{ MVA}$

Motor:  $S_{rmot} = \frac{P_r}{\eta \cdot \cos\phi_r} = 267 \text{ kVA}$

$S_{kmot} = 6.6 \cdot S_{rmot} = 1.76 \text{ MVA}$  for the first 5-6 periods (at 50 Hz about 100 ms)

#### Calculation of the short-circuit current for the selection of circuit-breakers

##### Selection of CB1

For circuit-breaker CB1, the worst condition arises when the fault occurs right downstream of the circuit-breaker itself. In the case of a fault right upstream, the circuit-breaker would be involved only by the fault current flowing from the motor, which is remarkably smaller than the network contribution.

## 6 Calculation of short-circuit current

The circuit, seen from the fault point, is represented by the series of the network with the transformer. According to the previous rules, the short-circuit power is determined by using the following formula:

$$S_{kCB1} = \frac{S_{knet} \cdot S_{ktrafo}}{S_{knet} + S_{ktrafo}} = 25.35 \text{ MVA}$$

the maximum fault current is:

$$I_{kCB1} = \frac{S_{kCB1}}{\sqrt{3} \cdot U_r} = 36.6 \text{ kA}$$

The transformer LV side rated current is equal to 2309 A; therefore the circuit-breaker to select is an Emax E3N 2500.

Using the chart shown in Figure 1, it is possible to find  $I_{kCB1}$  from the curve with  $S_{kUP} = S_{knet} = 500 \text{ MVA}$  corresponding to  $S_{kEL} = S_{ktrafo} = 26.7 \text{ MVA}$ :

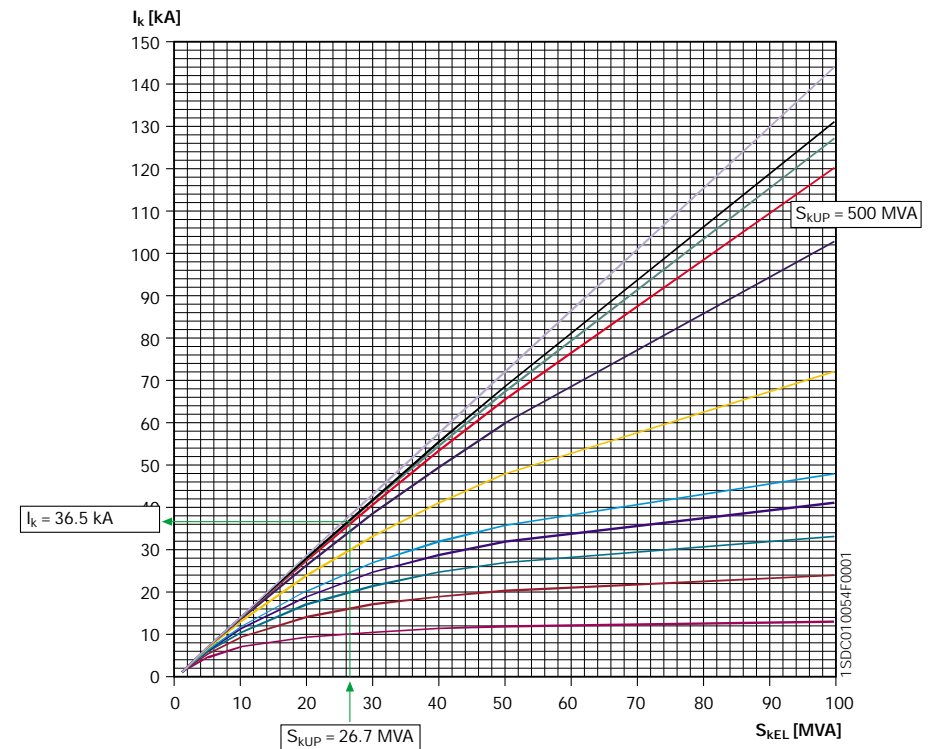

## 6 Calculation of short-circuit current

### Selection of CB2

For circuit-breaker CB2, the worst condition arises when the fault occurs right downstream of the circuit-breaker itself. The circuit, seen from the fault point, is represented by the series of the network with the transformer. The short-circuit current is the same used for CB1.

$$I_{kCB1} = \frac{S_{kCB1}}{\sqrt{3} \cdot U_r} = 36.6 \text{ kA}$$

The rated current of the motor is equal to 385 A; the circuit-breaker to select is a Tmax T5H 400.

### Selection of CB3

For CB3 too, the worst condition arises when the fault occurs right downstream of the circuit-breaker itself.

The circuit, seen from the fault point, is represented by two branches in parallel: the motor and the series of the network and transformer. According to the previous rules, the short-circuit power is determined by using the following formula:

Motor // (Network + Transformer)

$$S_{kCB3} = S_{kmot} + \frac{1}{\frac{1}{S_{knet}} + \frac{1}{S_{ktrafo}}} = 27.11 \text{ MVA}$$

$$I_{kCB3} = \frac{S_{kCB3}}{\sqrt{3} \cdot U_r} = 39.13 \text{ kA}$$

The rated current of the load L is equal to 1443 A; the circuit-breaker to select is a Tmax T7S1600 or an Emax X1B1600.

### Example 2

The circuit shown in the diagram is constituted by the supply, two transformers in parallel and three loads.

Upstream network:  $U_{r1} = 20000 \text{ V}$   
 $S_{knet} = 500 \text{ MVA}$

Transformers 1 and 2:  $S_r = 1600 \text{ kVA}$   
 $u_k\% = 6\%$   
 $U_{1r}/U_{2r} = 20000/400$

Load L1:  $S_r = 1500 \text{ kVA}$ ;  $\cos\phi = 0.9$ ;  
 Load L2:  $S_r = 1000 \text{ kVA}$ ;  $\cos\phi = 0.9$ ;  
 Load L3:  $S_r = 50 \text{ kVA}$ ;  $\cos\phi = 0.9$ .

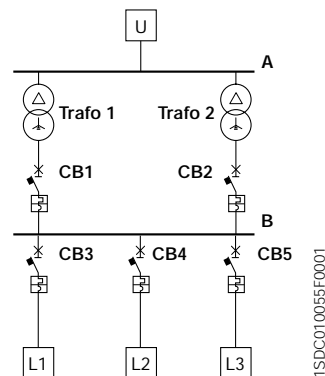

## 6 Calculation of short-circuit current

Calculation of the short-circuit powers of different elements:

Network  $S_{knet} = 500 \text{ MVA}$

Transformers 1 and 2  $S_{ktrafo} = \frac{S_r}{u_k\%} \cdot 100 = 26.7 \text{ MVA}$

### Selection of CB1 (CB2)

For circuit-breaker CB1 (CB2) the worst condition arises when the fault occurs right downstream of the circuit-breaker itself. According to the previous rules, the circuit seen from the fault point, is equivalent to the parallel of the two transformers in series with the network: Network + (Trafo 1 // Trafo 2).

The short-circuit current obtained in this way corresponds to the short-circuit current at the busbar. This current, given the symmetry of the circuit, is distributed equally between the two branches (half each). The current which flows through CB1 (CB2) is therefore equal to half of that at the busbar.

$$S_{kbusbar} = \frac{S_{knet} \cdot (S_{ktrafo1} + S_{ktrafo2})}{S_{knet} + (S_{ktrafo1} + S_{ktrafo2})} = 48.2 \text{ MVA}$$

$$I_{kbusbar} = \frac{S_{kbusbar}}{\sqrt{3} \cdot U_r} = 69.56 \text{ kA}$$

$$I_{kCB1(2)} = \frac{I_{kbusbar}}{2} = 34.78 \text{ kA}$$

The circuit-breakers CB1(CB2) to select, with reference to the rated current of the transformers, are Emax E3N 2500.

### Selection of CB3-CB4-CB5

For these circuit-breakers the worst condition arises when the fault occurs right downstream of the circuit-breakers themselves. Therefore, the short-circuit current to be taken into account is that at the busbar:

$$I_{kCB3} = I_{kbusbar} = 69.56 \text{ kA}$$

The circuit-breakers to select, with reference to the current of the loads, are:  
 CB3: Emax E3S 2500  
 CB4: Emax E2S 1600  
 CB5: Tmax T2H 160





## 6 Calculation of short-circuit current

### 6.5 Algebra of sequences

#### 6.5.1 General aspects

It is possible to study a symmetrical, balanced three-phase network in quite a simple way by reducing the three-phase network to a single-phase one having the same value of rated voltage as the three-phase system line-to-line voltage. Asymmetric networks cannot be reduced to the study of a single-phase network just because of this unbalance. In this case, being impossible any simplification, it is necessary to proceed according to the analysis methods typical for the solution of electrical systems.

The modelling technique allowing the calculation of an asymmetric and unbalanced network by converting it to a set of three balanced networks that each can be represented by a single-phase equivalent circuit easily solvable is the method of symmetrical components.

This method derives from mathematical considerations according to which any set of three phasors<sup>1</sup> can be divided into three sets of phasors with the following characteristics:

- a balanced set, called *positive sequence*, formed by three phasors of equal magnitude shifted by 120° and having the same phase sequence as the original system
- a balanced set, called *negative sequence*, formed by three phasors of equal magnitude shifted by 120° and having inverse phase sequence to that of the original system
- a *zero sequence* set formed by three phasors of equal magnitude in phase.

Figure 1

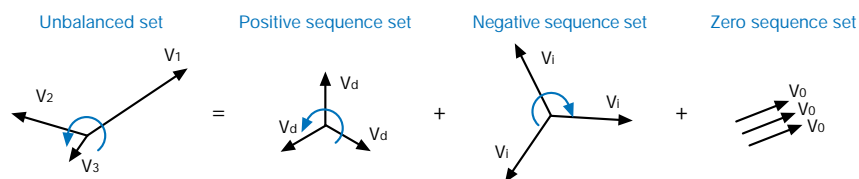

<sup>1</sup> The phasor is a vectorial representation of magnitude which varies in time. A signal of type  $v(t) = \sqrt{2} \cdot V \cdot \cos(\omega \cdot t + \varphi)$  is represented by the phasor  $\bar{V} = V \cdot e^{j\varphi}$

## 6 Calculation of short-circuit current

### 6.5.2 Positive, negative and zero sequence systems

The following relationships\* represent the link between the quantities of the three-phase balanced network and the positive, negative and zero sequence systems:

$$\begin{aligned} \bar{V}_0 &= \frac{1}{3} (\bar{V}_1 + \bar{V}_2 + \bar{V}_3) & \bar{I}_0 &= \frac{1}{3} (\bar{I}_1 + \bar{I}_2 + \bar{I}_3) & \bar{V}_1 &= \bar{V}_0 + \bar{V}_d + \bar{V}_i & \bar{I}_1 &= \bar{I}_0 + \bar{I}_d + \bar{I}_i \\ \bar{V}_d &= \frac{1}{3} (\bar{V}_1 + \alpha \cdot \bar{V}_2 + \alpha^2 \cdot \bar{V}_3) & \bar{I}_d &= \frac{1}{3} (\bar{I}_1 + \alpha \cdot \bar{I}_2 + \alpha^2 \cdot \bar{I}_3) & \bar{V}_2 &= \bar{V}_0 + \alpha^2 \cdot \bar{V}_d + \alpha \cdot \bar{V}_i & \bar{I}_2 &= \bar{I}_0 + \alpha^2 \cdot \bar{I}_d + \alpha \cdot \bar{I}_i \\ \bar{V}_i &= \frac{1}{3} (\bar{V}_1 + \alpha^2 \cdot \bar{V}_2 + \alpha \cdot \bar{V}_3) & \bar{I}_i &= \frac{1}{3} (\bar{I}_1 + \alpha^2 \cdot \bar{I}_2 + \alpha \cdot \bar{I}_3) & \bar{V}_3 &= \bar{V}_0 + \alpha \cdot \bar{V}_d + \alpha^2 \cdot \bar{V}_i & \bar{I}_3 &= \bar{I}_0 + \alpha \cdot \bar{I}_d + \alpha^2 \cdot \bar{I}_i \end{aligned}$$

\* In the formulas, the subscripts relevant to positive-sequence, negative-sequence and zero-sequence components are indicated by "d", "i" and "0" respectively.

The complex constant  $\alpha = -\frac{1}{2} + j\frac{\sqrt{3}}{2}$  is a versor which, multiplied by a vector, rotates the vector by 120° in a positive direction (counterclockwise).

The complex constant  $\alpha^2 = -\frac{1}{2} - j\frac{\sqrt{3}}{2}$  operates a -120° rotation.

Some useful properties of this set of three vectors are:

$$\begin{aligned} 1 + \alpha + \alpha^2 &= 0 \\ |\alpha^2 - \alpha| &= \sqrt{3} \end{aligned}$$

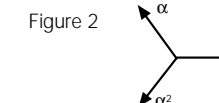
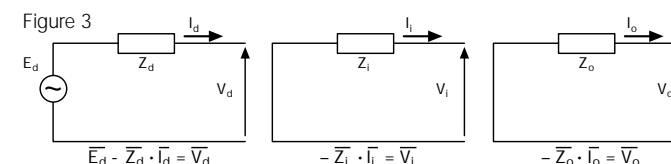

Figure 2

Therefore, it is possible to state that a real three-phase network may be replaced by three single-phase networks related to the three positive, negative and zero sequences, by substituting each component with the corresponding equivalent circuit. If generators can be considered symmetrical as it occurs in plant practice, by considering as a positive sequence set the one they generate, the three single-phase networks are defined by the following circuits and equations:



Where:

- $E_d$  is the line-to-neutral voltage ( $E_d = \frac{U_r}{\sqrt{3}}$ ) of the section upstream the fault
- $Z$  is the system impedance upstream the fault location
- $I$  is the fault current
- $V$  is the voltage measured at the fault location.

## 6 Calculation of short-circuit current

### 6.5.3 Calculation of short-circuit current with the algebra of sequences

Without going into the details of a theoretical treatment, it is possible to show the procedure to simplify and resolve the electrical network under a pre-established fault condition through an example.

#### Isolated line-to-line fault

The diagram showing this fault typology and the link between currents and voltages, may be represented as follows:

Figure 4

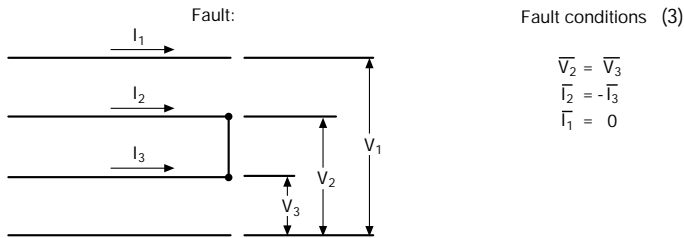

By using the given fault conditions and the formula 1), it follows that:

$$\begin{aligned} V_d &= V_i \\ I_d &= -I_i \\ I_0 &= 0 \text{ therefore } V_0 = 0 \end{aligned} \quad (4)$$

These relationships applied to the three sequence circuits of Figure 3 allow the definition of the sequence network equivalent to the three-phase network under study and representing the initial fault condition. This network may be represented as follows:

Figure 5

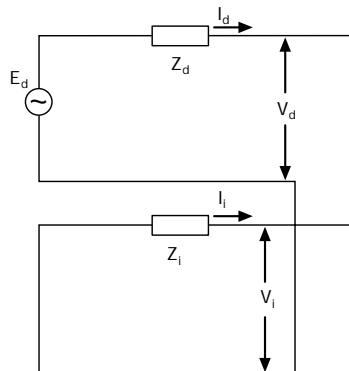

## 6 Calculation of short-circuit current

By solving this simple network (constituted by series-connected elements) in relation to the current  $I_d$ , the following is obtained:

$$\bar{I}_d = \frac{\bar{E}_d}{\bar{Z}_d + \bar{Z}_i} \quad 5)$$

By using formulas 2) referred to the current, and formulas 4), it follows that:

$$\bar{I}_2 = (\alpha^2 - \alpha) \cdot \bar{I}_d \quad \bar{I}_3 = (\alpha - \alpha^2) \cdot \bar{I}_d$$

Since  $|\alpha^2 - \alpha|$  results to be equal to  $\sqrt{3}$ , the value of the line-to-line short-circuit current in the two phases affected by the fault can be expressed as follows:

$$|\bar{I}_2| = |\bar{I}_3| = |\bar{I}_{k2}| = \sqrt{3} \cdot \left| \frac{\bar{E}_d}{\bar{Z}_d + \bar{Z}_i} \right|$$

Using formulas 2) referred to the voltage, and formulas 4) previously found, the following is obtained:

$$\begin{aligned} \bar{V}_1 &= 2 \cdot \bar{V}_i & 6) \text{ for the phase not affected by the fault} \\ \bar{V}_2 &= \bar{V}_3 = (\alpha^2 + \alpha) \cdot \bar{V}_d = -\bar{V}_d & 7) \text{ for the phases affected by the fault} \end{aligned}$$

Through the negative sequence circuit, relation 6) can be written as  $\bar{V}_1 = -2 \cdot \bar{Z}_i \cdot \bar{I}_i$ .

Further to the above, and since  $\bar{I}_d = -\bar{I}_i$ , the phase not affected by the fault shall be:

$$\bar{V}_1 = \frac{2 \cdot \bar{Z}_i}{\bar{Z}_d + \bar{Z}_i} \cdot \bar{E}_d$$

For the phases affected by the fault, being  $\bar{V}_d = \bar{V}_i = \frac{\bar{V}_1}{2}$ , it results:

$$\bar{V}_2 = \bar{V}_3 = -\frac{\bar{V}_1}{2} = \frac{\bar{Z}_i \cdot \bar{E}_d}{\bar{Z}_d + \bar{Z}_i}$$

Making reference to the previous example, it is possible to analyse all fault typologies and to express the fault currents and voltages as a function of the impedances of the sequence components.

## 6 Calculation of short-circuit current

A summary is given in Table 1 below:

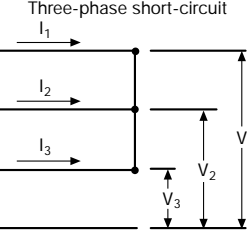
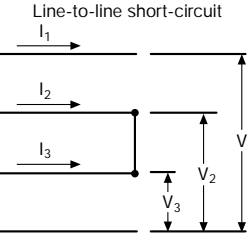
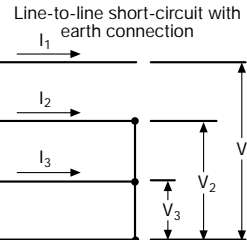
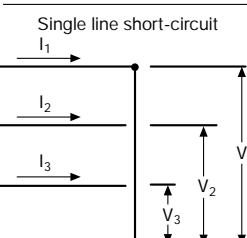
Type of fault	Fault conditions:	Current	Voltage on phases
Three-phase short-circuit 	$\bar{V}_1 = \bar{V}_2 = \bar{V}_3$ $\bar{I}_1 + \bar{I}_2 + \bar{I}_3 = 0$	$ \bar{I}_{k3}  =  \bar{I}_1  = \frac{U_n}{\sqrt{3} \cdot  Z_d }$	$\bar{V}_1 = \bar{V}_2 = \bar{V}_3 = 0$
Line-to-line short-circuit 	$\bar{V}_2 = \bar{V}_3$ $\bar{I}_2 = -\bar{I}_3$	$ \bar{I}_{k2}  =  \bar{I}_2  = \frac{U_n}{ Z_d + \bar{Z}_i }$	$ \bar{V}_1  = \frac{2}{\sqrt{3}} \cdot U_n \cdot \left  \frac{\bar{Z}_i}{Z_d + \bar{Z}_i} \right $ $ \bar{V}_d  =  \bar{V}_d  = \frac{U_n}{\sqrt{3}} \cdot \left  \frac{\bar{Z}_i}{Z_d + \bar{Z}_i} \right $
Line-to-line short-circuit with earth connection 	$\bar{V}_2 = \bar{V}_3 = 0$ $\bar{I}_1 = 0$	$ \bar{I}_2  = U_n \cdot \left  \frac{(1 + \alpha^2) \cdot \bar{Z}_i + \bar{Z}_0}{Z_d \cdot \bar{Z}_i + \bar{Z}_i \cdot \bar{Z}_0 + \bar{Z}_0 \cdot Z_d} \right $ $ \bar{I}_3  = U_n \cdot \left  \frac{(1 + \alpha) \cdot \bar{Z}_i + \bar{Z}_0}{Z_d \cdot \bar{Z}_i + \bar{Z}_i \cdot \bar{Z}_0 + \bar{Z}_0 \cdot Z_d} \right $ $ \bar{I}_{ground}  =  \bar{I}_2 + \bar{I}_3  = U_n \cdot \left  \frac{\bar{Z}_i}{Z_d \cdot \bar{Z}_i + \bar{Z}_i \cdot \bar{Z}_0 + \bar{Z}_0 \cdot Z_d} \right $	$\bar{V}_2 = \bar{V}_3 = 0$ $ \bar{V}_1  = \sqrt{3} \cdot U_n \cdot \left  \frac{\bar{Z}_i \cdot \bar{Z}_0}{Z_d \cdot \bar{Z}_i + \bar{Z}_i \cdot \bar{Z}_0 + \bar{Z}_0 \cdot Z_d} \right $
Single line short-circuit 	$\bar{V}_1 = 0$ $\bar{I}_2 = \bar{I}_3 = 0$	$ \bar{I}_{k1}  =  \bar{I}_1  = \frac{\sqrt{3} \cdot U_n}{ Z_d + \bar{Z}_i + \bar{Z}_0 }$	$\bar{V}_1 = 0$ $ \bar{V}_2  = U_n \cdot \left  \frac{\bar{Z}_i \cdot \alpha \cdot \bar{Z}_0}{Z_d + \bar{Z}_i + \bar{Z}_0} \right $ $ \bar{V}_3  = U_n \cdot \left  \frac{-\alpha \cdot \bar{Z}_i + \bar{Z}_0}{Z_d + \bar{Z}_i + \bar{Z}_0} \right $

## 6 Calculation of short-circuit current

### 6.5.4 Positive, negative and zero sequence short-circuit impedances of electrical equipment

Each component of an electrical network (utility – transformer – generator – cable) may be represented by a positive, negative and zero sequence impedance value.

#### Utility

By utility it is meant the distribution supply network (usually MV) from which the plant is fed. It is characterized by positive and negative sequence elements, whereas the zero sequence impedance is not taken into consideration since the delta-connected windings of the primary circuit of the transformer impede the zero sequence current. As regards the existing impedances, it can be written:

$$Z_d = Z_1 = Z_{NET} \frac{U_r}{\sqrt{3} \cdot I_{k3}}$$

#### Transformer

It is characterized by positive and negative sequence elements; besides, as a function of the connection of the windings and of the distribution system on the LV side, the zero sequence component may be present too.

Thus, it is possible to say that:

$$Z_d = Z_1 = Z_T = \frac{uk \%}{100} \cdot \frac{U_r^2}{S_r}$$

whereas the zero sequence component can be expressed as:

$Z_0 = Z_1$  when the flow of zero sequence currents in the two windings is possible  
 $Z_0 = \infty$  when the flow of zero sequence currents in the two windings is impossible

#### Cable

It is characterized by positive, negative and zero sequence elements which vary as a function of the return path of the short-circuit current.

As regards the positive and negative sequence components, it is possible to say that:

$$Z_d = Z_1 = Z_C = R_C + j X_C$$

To evaluate the zero sequence impedance, it is necessary to know the return path of the current:

$Z_0 = Z_C + j3 \cdot Z_{NC} = (R_C + 3 \cdot R_{NC}) + j(X_C + 3 \cdot X_{NC})$   
 Return through the neutral wire (phase-to-neutral fault)

$Z_0 = Z_C + j3 \cdot Z_{PEC} = (R_C + 3 \cdot R_{PEC}) + j(X_C + 3 \cdot X_{PEC})$   
 Return through PE (phase-to-PE conductor fault in TN-S system)

$Z_0 = Z_{EC} + j3 \cdot Z_{EC} = (R_C + 3 \cdot R_{EC}) + j(X_C + 3 \cdot X_{EC})$   
 Return through ground (phase-to-ground fault in TT system)

where:

- $Z_C$ ,  $R_C$  and  $X_C$  refer to the line conductor
- $Z_{NC}$ ,  $R_{NC}$  and  $X_{NC}$  refer to the neutral conductor
- $Z_{PEC}$ ,  $R_{PEC}$  and  $X_{PEC}$  refer to the protection conductor PE
- $Z_{EC}$ ,  $R_{EC}$  and  $X_{EC}$  refer to the ground.

## 6 Calculation of short-circuit current

### Synchronous generators

Generally speaking, positive, negative and zero sequence reactances of synchronous generators (and also of rotating machines) have different values. For the positive sequence, only the sub transient reactance  $X_d''$  is used, since, in this case, the calculation of the fault current gives the highest value.

The negative sequence reactance is very variable, ranging between the values of  $X_d'$  and  $X_q'$ . In the initial instants of the short-circuit,  $X_d'$  and  $X_q'$  do not differ very much and therefore we may consider  $X_1 = X_d'$ . On the contrary if  $X_d'$  and  $X_q'$  are remarkably different, it is possible to use a value equal to the average value of the two reactances; it follows that:

$$X_1 = \frac{X_d' + X_q'}{2}$$

The zero sequence reactance is very variable too and results to be lower than the other two above mentioned reactances. For this reactance, a value equal to 0.1 to 0.7 times the negative or positive sequence reactances may be assumed and can be calculated as follows:

$$X_0 = \frac{x_0\%}{100} \cdot \frac{U_r^2}{S_r}$$

where  $x_0\%$  is a typical parameter of the machine. Besides, the zero sequence component results to be influenced also by the grounding modality of the generator through the introduction of the parameters  $R_G$  and  $X_G$ , which represent, respectively, the grounding resistance and the reactance of the generator. If the star point of the generator is inaccessible or anyway non-earthed, the grounding impedance is  $\infty$ .

To summarize, the following expressions are to be considered for the sequence impedances:

$$\begin{aligned} Z_d &= (R_a + j \cdot X_d'') \\ Z_1 &= (R_a + j \cdot X_d'') \\ Z_0 &= R_a + 3 \cdot R_G + j \cdot (X_0 + 3 \cdot X_G) \end{aligned}$$

where  $R_a$  is the stator resistance defined as  $R_a = \frac{X_d''}{2 \cdot \pi \cdot f \cdot T_a}$ , with  $T_a$  as stator time constant.

## 6 Calculation of short-circuit current

### Loads

If the load is passive, the impedance shall be considered as infinite.

If the load is not passive, as it could be for an asynchronous motor, it is possible to consider the machine represented by the impedance  $Z_M$  for the positive and negative sequence, whereas for the zero sequence the value  $Z_{0M}$  must be given by the manufacturer. Besides, if the motors are not earthed, the zero sequence impedance shall be  $\infty$ .

Therefore:

$$Z_d = Z_1 = Z_M = (R_M + j \cdot X_M)$$

with  $Z_M$  equal to

$$Z_M = \frac{U_r^2}{I_{LR}} \cdot \frac{1}{S_r}$$

where:

$I_{LR}$  is the current value when the rotor is blocked by the motor

$I_r$  is the rated current of the motor

$S_r = \frac{P_r}{(\eta \cdot \cos\phi_r)}$  is the rated apparent power of the motor

The ratio  $\frac{R_M}{X_M}$  is often known; for LV motors, this ratio can be considered equal

to 0.42 with  $X_M = \frac{Z_M}{\sqrt{1 + \left(\frac{R_M}{X_M}\right)^2}}$ , from which  $X_M = 0.922 \cdot Z_M$  can be determined.

## 6 Calculation of short-circuit current

### 6.5.5 Formulas for the calculation of the fault currents as a function of the electrical parameters of the plant

Through Table 1 and through the formulas given for the sequence impedances expressed as a function of the electrical parameters of the plant components, it is possible to calculate the different short-circuit currents.

In the following example, a network with a MV/LV transformer with delta primary winding and secondary winding with grounded star point is taken into consideration and a line-to-line fault is assumed downstream the cable distribution line.

Figure 6

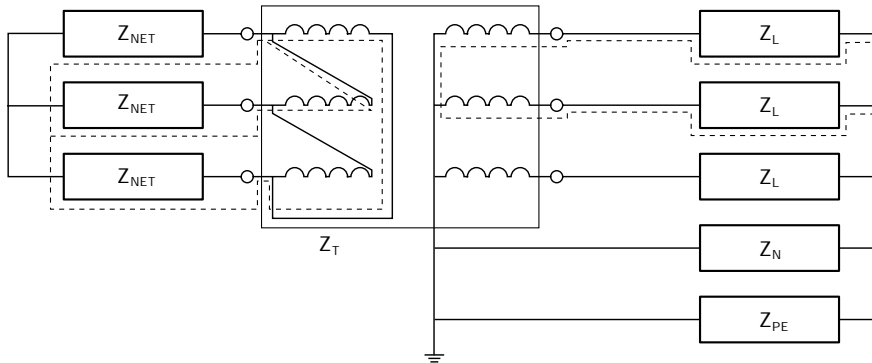

Applying the algebra of sequences:

$$I_{k2} = \frac{\sqrt{3} \cdot E_d}{(Z_d + Z_i)}$$

the impedances relevant to the positive and negative sequences under examination are:

$$Z_d = Z_i = Z_{NET} + Z_T + Z_L$$

considering that  $E_d = \frac{U_r}{\sqrt{3}}$ , the following is obtained:

$$I_{k2} = \frac{\sqrt{3} \cdot E_d}{(Z_d + Z_i)} = \frac{U_r}{2 \cdot (Z_{NET} + Z_T + Z_L)}$$

where:

- $U_r$  is the rated voltage on the LV side
- $Z_T$  is the impedance of the transformer
- $Z_L$  is the impedance of the phase conductor
- $Z_{NET}$  is the impedance of the upstream network

By making reference to the previous example, it is possible to obtain Table 2 below, which gives the expressions for the short-circuit currents according to the different typologies of fault.

## 6 Calculation of short-circuit current

Table 2

Three-phase fault $I_{k3}$		$I_{k3} = \frac{U_r}{\sqrt{3} \cdot (Z_{NET} + Z_T + Z_L)}$
Line-to-line fault $I_{k2}$		$I_{k2} = \frac{U_r}{2 \cdot (Z_{NET} + Z_T + Z_L)}$
Single-phase fault $I_{k1}$ (line-to-neutral or line-to-PE)		$I_{k1} = \frac{U_r}{\sqrt{3} \cdot \left( \frac{2}{3} \cdot Z_{NET} + Z_T + Z_L + Z_{PE} \right)}$ $I_{k1} = \frac{U_r}{\sqrt{3} \cdot \left( \frac{2}{3} \cdot Z_{NET} + Z_T + Z_L + Z_N \right)}$

Where:

- $U_r$  is the rated voltage on the LV side
- $Z_T$  is the impedance of the transformer
- $Z_L$  is the impedance of the phase conductor
- $Z_{NET}$  is the impedance of the upstream network
- $Z_{PE}$  is the impedance of the protection conductor (PE)
- $Z_N$  is the impedance of the neutral conductor

## 6 Calculation of short-circuit current

Table 3 below summarizes the relations for the fault currents, taking into account the upstream defined or infinite power network values and the distance of the fault from the transformer.

Table 3

	Upstream defined power network		Upstream infinite power network $Z_{NET} \rightarrow 0$	
	Far-from the transformer	Near the transformer $Z_L \rightarrow 0, Z_{PE} \text{ (o } Z_N) \rightarrow 0$	Far-from the transformer	Near the transformer $Z_L \rightarrow 0, Z_{PE} \text{ (o } Z_N) \rightarrow 0$
$I_{k3}$	$I_{k3} = \frac{U_f}{\sqrt{3} \cdot (Z_{NET} + Z_T + Z_L)}$	$I_{k3} = \frac{U_f}{\sqrt{3} \cdot (Z_{NET} + Z_T)}$	$I_{k3} = \frac{U_f}{\sqrt{3} \cdot (Z_T + Z_L)}$	$I_{k3} = \frac{U_f}{\sqrt{3} \cdot (Z_T)}$
$I_{k2}$	$I_{k2} = \frac{U_f}{2 \cdot (Z_{NET} + Z_T + Z_L)}$	$I_{k2} = \frac{U_f}{2 \cdot (Z_{NET} + Z_T)}$	$I_{k2} = \frac{U_f}{2 \cdot (Z_T + Z_L)}$	$I_{k2} = \frac{U_f}{2 \cdot (Z_T)}$
	$I_{k2} < I_{k3}$	$I_{k2} = 0.87 \cdot I_{k3}$	$I_{k2} = 0.87 \cdot I_{k3}$	$I_{k2} = 0.87 \cdot I_{k3}$
$I_{k1}$	$I_{k1} = \frac{U_f}{\sqrt{3} \cdot \left(\frac{2}{3} \cdot Z_{NET} + Z_T + Z_L + Z_{PE}\right)}$	$I_{k1} = \frac{U_f}{\sqrt{3} \cdot \left(\frac{2}{3} \cdot Z_{NET} + Z_T\right)}$	$I_{k1} = \frac{U_f}{\sqrt{3} \cdot (Z_T + Z_L + Z_{PE})}$	$I_{k1} = \frac{U_f}{\sqrt{3} \cdot (Z_T)}$
	$I_{k1} > I_{k3}$ if $Z_{NET} > 3 \cdot Z_{PE}$	$I_{k1} > I_{k3}$	$I_{k1} \leq I_{k3}$	$I_{k1} = I_{k3}$

## 6 Calculation of short-circuit current

### 6.6 Calculation of the peak value of the short-circuit current

The electrodynamic effects of the short-circuit currents are particularly dangerous for the bus ducts, but they can also damage cables. The peak current is important also to evaluate the  $I_{cm}$  value of the circuit-breaker.

The  $I_{cm}$  value is also bound to the  $I_{cu}$  value, according to Table 16 of the Standard IEC 60947-1. With reference to the short-circuit current of the plant, it shall be  $I_{cm} > I_{kp}$ .

The peak current of a plant may be calculated by the following formula (see Std. IEC 60909-0):

$$I_{kp} = I_k' \cdot \sqrt{2} \cdot \left(1.02 + 0.98 \cdot e^{-\frac{3 \cdot R}{X}}\right)$$

where:

- $I_k'$  is the short-circuit current (rms value) at the initial instant of the short-circuit
- $R$  is the resistive component of the short-circuit impedance at the fault location
- $X$  is the reactive component of the short-circuit current at the fault location

When the power factor  $\cos\phi_k$  is known, it is possible to write:

$$I_{kp} = I_k' \cdot \sqrt{2} \cdot \left(1.02 + 0.98 \cdot e^{-\frac{3}{\tan\phi_k}}\right)$$

---

## 6 Calculation of short-circuit current

---

### 6.7 Considerations about UPS (Uninterruptible Power Supplies) contribution to short-circuit currents

In the following considerations particular attention is given to a double-conversion or UPS on-line, belonging to the category VFI (Voltage and Frequency Independent), for which the output voltage is independent of the mains voltage variations and frequency variations are controlled by this device within the standard limits prescribed by the Standards; this system is characterised by the following operating modalities:

- under normal operating conditions, in the presence of the network voltage, the load is fed by the network itself through the UPS;
- under emergency conditions (lack of network), power to the load is supplied by the battery and by the inverter ("island supply" with UPS disconnected from the mains);
- in case of temporary overcurrent required by the load (e.g. motor start-up), power supply to the load is guaranteed by the network through the static switch which excludes the UPS;
- in case of maintenance, for example due to a fault on the UPS, the load is fed by the network through a manual bypass switch, by temporarily giving up the availability of emergency power supply.

As regards the dimensioning of the protections on the supply side of the UPS, it is necessary to know the characteristics of the network voltage and of the short-circuit current; for the dimensioning of the protections on the load side, it is necessary to know the current values let through by the UPS.

If power supply of the loads is provided directly from the network through manual bypass, also the circuit-breaker on the load side must have a breaking capacity (I<sub>cu</sub>) suitable for the short-circuit current of the supply-side network.

Furthermore, if required, an evaluation of the protection co-ordination in relation to the operating conditions is necessary.

---

## 6 Calculation of short-circuit current

However, in order to choose the suitable protections, it is important to distinguish between two operating conditions for UPS:

### 1) UPS under normal operating conditions

a) Overload condition:

- if due to a possible fault on the battery, this condition affects only the circuit-breaker on the supply-side of the UPS (also likely the intervention of the protections inside the battery);
- if required by the load, this condition might not be supported by the UPS, which is bypassed by the static converter.

b) Short-circuit condition:

The short-circuit current is limited by the dimensioning of the thyristors of the bridge inverter. In the practice, UPS may supply a maximum short-circuit current equal to 150 to 200% of the rated value. In the event of a short-circuit, the inverter supplies the maximum current for a limited time (some hundreds of milliseconds) and then switches to the network, so that power to the load is supplied by the bypass circuit.

In this case, selectivity between the circuit-breaker on the supply side and the circuit-breaker on the load side is important in order to disconnect only the load affected by the fault.

The bypass circuit, which is also called static switch, and is formed by thyristors protected by extrarapid fuses, can feed the load with a higher current than the inverter; this current results to be limited by the dimensioning of the thyristors used, by the power installed and by the provided protections.

The thyristors of the bypass circuit are usually dimensioned to withstand the following overload conditions:

125%	for 600 seconds
150%	for 60 seconds
700%	for 600 milliseconds
1000%	for 100 milliseconds

Generally, more detailed data can be obtained from the technical information given by the manufacturer.



## 6 Calculation of short-circuit current

### 2) UPS under emergency operating conditions

#### a) Overload condition:

this condition, involving the load-side circuit-breaker only, is supported by the battery with inverter, which presents an overload condition usually calculable in the following orders of magnitude:

1.15 x  $I_n$  for indefinite time

1.25 x  $I_n$  for 600 seconds

1.5 x  $I_n$  for 60 seconds

2 x  $I_n$  for 1 seconds

Generally, more detailed data can be obtained from the technical information given by the manufacturer.

#### b) Short-circuit condition:

the maximum current towards the load is limited by the inverter circuit only (with a value from 150 to 200% of the nominal value). The inverter feeds the short-circuit for a certain period of time, usually limited to some milliseconds, after which the UPS unit disconnects the load leaving it without supply. In this operating modality, it is necessary to obtain selectivity between the circuit-breaker on the load side and the inverter, which is quite difficult due to the reduced tripping times of the protection device of the inverter.

## Annex A: Calculation tools

### A.1 Slide rules

These slide rules represent a valid instrument for a quick and approximate dimensioning of electrical plants.

All the given information is connected to some general reference conditions; the calculation methods and the data reported are gathered from the IEC Standards in force and from plant engineering practice. The instruction manual enclosed with the slide rules offers different examples and tables showing the correction coefficients necessary to extend the general reference conditions to those actually required.

These two-sided slide rules are available in four different colors, easily identified by subject:

- yellow slide rule: cable sizing;
- orange slide rule: cable verification and protection;
- green slide rule: protection coordination;
- blue slide rule: motor and transformer protection.

Figure 7

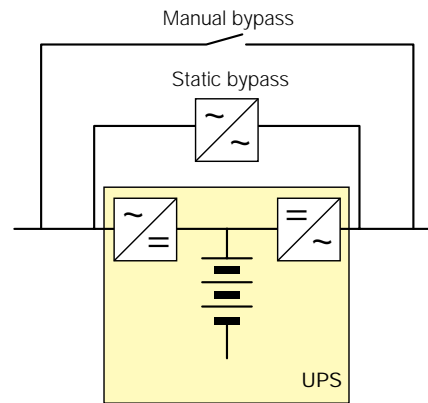

UPS on-line with static switch

Figure 8

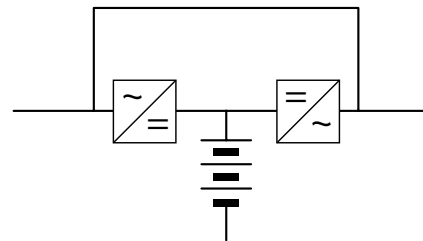

UPS off-line: loads directly fed by the network

## Annex A: Calculation tools

### Yellow slide rule: cable sizing

Side ●

Definition of the current carrying capacity, impedance and voltage drop of cables.

Side ●●

Calculation of the short-circuit current for three-phase fault on the load side of a cable line with known cross section and length.

In addition, a diagram for the calculation of the short-circuit current on the load side of elements with known impedance.

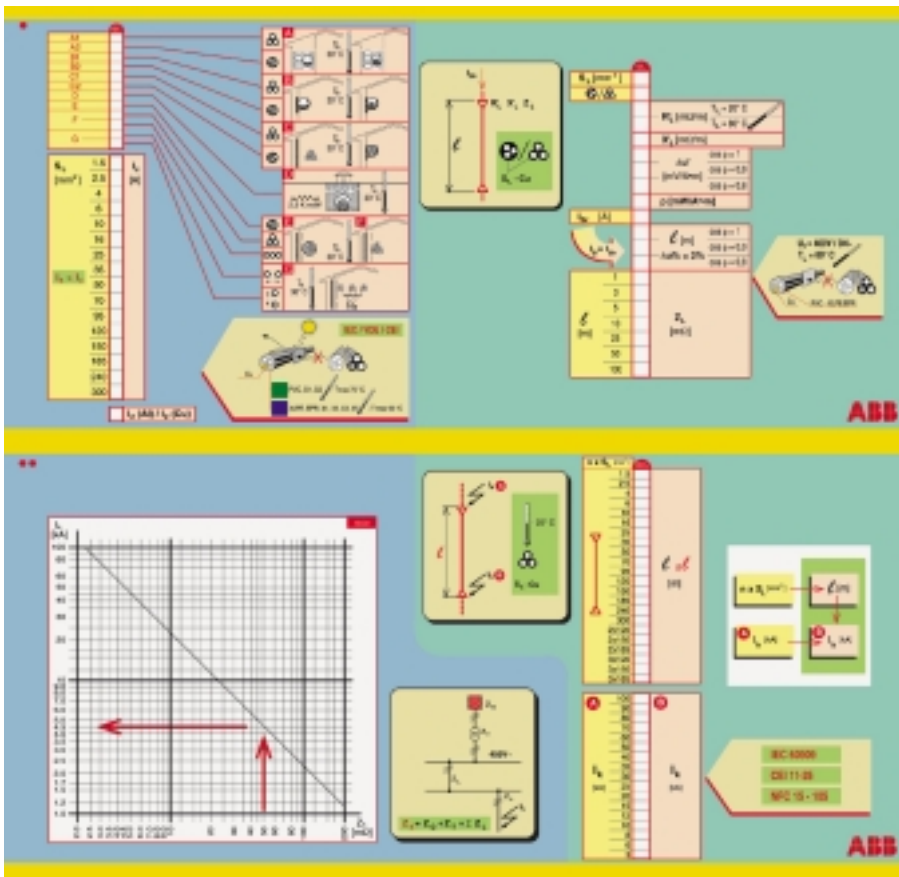

1SDC008059F0001

## Annex A: Calculation tools

### Orange slide rule: cable verification and protection

Side ●

Verification of cable protection against indirect contact and short-circuit with ABB SACE MCCBs (moulded-case circuit-breakers).

Side ●●

Verification of cable protection against indirect contact and short-circuit with ABB MCBs (modular circuit-breakers).



1SDC008060F0001

## Annex A: Calculation tools

### Green slide rule: protection coordination

Side ●

Selection of the circuit-breakers when back-up protection is provided.

Side ●●

Definition of the limit selectivity current for the combination of two circuit-breakers in series.

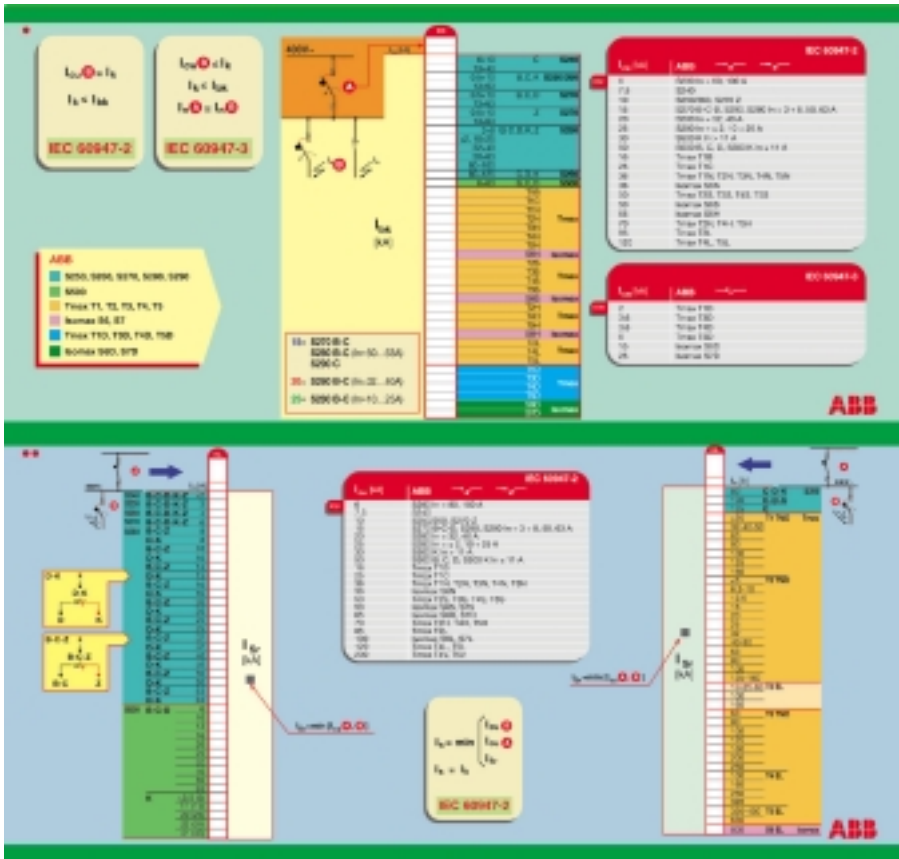

1SDC008061F0001

## Annex A: Calculation tools

### Blue slide rule: motor and transformer protection

Side ●

Selection and coordination of the protection devices for the motor starter, DOL start-up (type 2 coordination in compliance with the Standard IEC 60947-4-1).

Side ●●

Sizing of a transformer feeder.

In addition, a diagram for the calculation of the short-circuit current on the load side of transformers with known rated power.

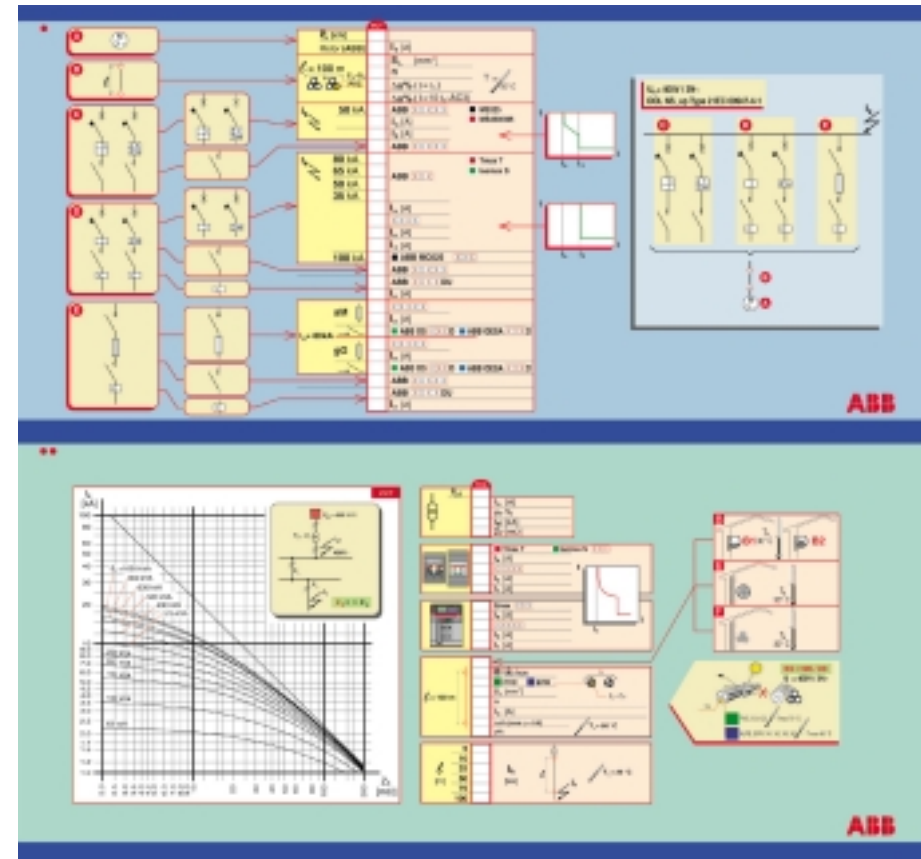

1SDC008062F0001

## Annex A: Calculation tools

### A.2 DOCWin

DOCWin is a software for the dimensioning of electrical networks, with low or medium voltage supply.

Networks can be completely calculated through simple operations starting from the definition of the single-line diagram and thanks to the drawing functions provided by an integrated CAD software.

#### Drawing and definition of networks

Creation of the single-line diagram, with no limits to the network complexity. Meshed networks can also be managed.

- The diagram can be divided into many pages.
- The program controls the coherence of drawings in real time.
- It is possible to enter and modify the data of the objects which form the network by using a table.
- It is possible to define different network configurations by specifying the status (open/closed) of the operating and protective devices.

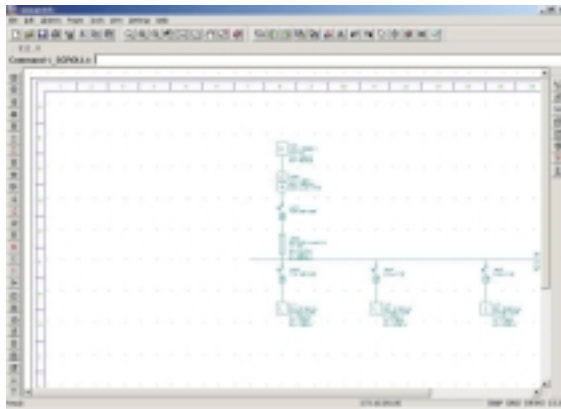

#### Supplies

- There are no pre-defined limits: the software manages MV and LV power supplies and generators, MV/LV and LV/LV transformers, with two or three windings, with or without voltage regulator, according to the requirements.

#### Network calculation

- Load Flow calculation using the Newton-Raphson method. The software can manage networks with multiple slacks and unbalances due to single- or two-phase loads. Magnitude and phase shift of the node voltage and of the branch current are completely defined for each point of the network, for both MV as well as LV.
- Calculation of the active and reactive power required by each single power source.

## Annex A: Calculation tools

- Management of local (motors) and centralized power factor correction with capacitor banks.
- Management of the demand factor for each single node of the network and of the utilization factor on the loads.
- Short-circuit current calculation for three-phase, phase-to-phase, phase-to-neutral, phase-to-ground faults. The calculation is also carried out for MV sections, in compliance with the Standards IEC 60909-1, IEC 61363-1 (naval installations) or with the method of symmetric components, taking into account also the time-variance contribution of rotary machines (generators and motors).
- Calculation of switchboard overtemperature in compliance with Standard IEC 60890. The power dissipated by the single apparatus is automatically derived by the data files of the software, and can be considered as a function of the rated current or of the load current.

#### Cable line sizing

- Cable line sizing according to thermal criteria in compliance with the following Standards: CEI 64-8 (tables CEI UNEL 35024-35026), IEC 60364, VDE 298-4, NFC 15-100, IEC 60092 (naval installations) and IEC 60890.
- Possibility of setting, as additional calculation criterion, the economic criteria stated in the Standard IEC 60827-3-2.
- Possibility of setting, as additional calculation criterion, the maximum allowed voltage drop.
- Automatic sizing of busbar trunking system.
- Sizing and check on the dynamic withstand of busbars in compliance with the Standard IEC 60865.

#### Curves and verifications

- Representation of:
  - time / current curves ( $I-t$ ),
  - current / let-through energy curves ( $I-I^2t$ ),
  - current limiting curves (peak): visual check of the effects of the settings on the trip characteristics of protection devices.

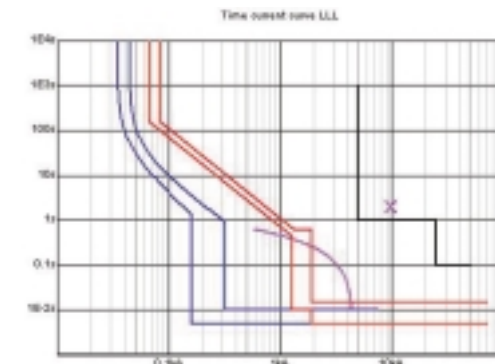

## Annex A: Calculation tools

- Representation of the curves of circuit-breakers, cables, transformers, motors and generators.
- Possibility of entering the curve of the utility and of the MV components point by point, to verify the tripping discrimination of protection devices.
- Verification of the maximum voltage drop at each load.
- Verification of the protection devices, with control over the setting parameters of the adjustable releases (both thermomagnetic as well as electronic).

### Selection of operating and protection devices

- Automatic selection of protection devices (circuit-breakers and fuses)
- Automatic selection of operating devices (contactors and switch disconnectors)
- Discrimination and back-up as selection criteria, with discrimination level adjustable for each circuit-breaker combination.

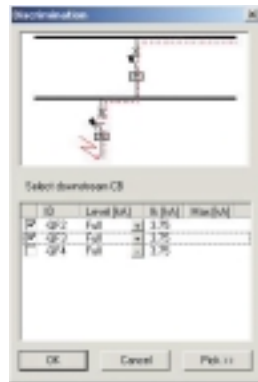

- Discrimination and back-up verification also through quick access to coordination tables.

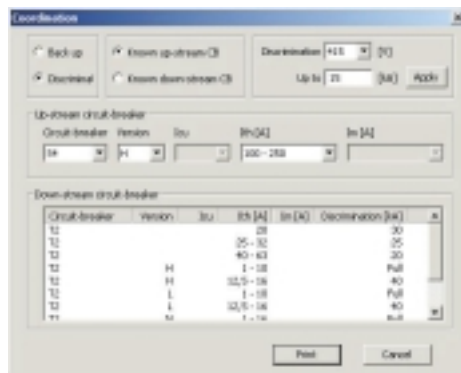

## Annex A: Calculation tools

- Motor coordination management through quick access to ABB tables.

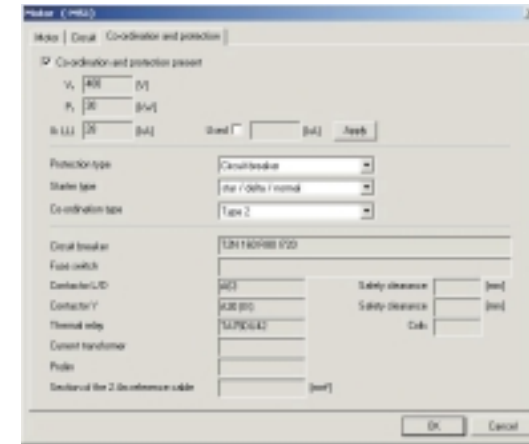

### Printouts

- Single-line diagram, curves and reports of the single components of the network can be printed by any printer supported by the hardware configuration.
- All information can be exported in the most common formats of data exchange.
- All print modes can be customized.

## Annex B: Calculation of load current I<sub>b</sub>

### Generic loads

The formula for the calculation of the load current of a generic load is:

$$I_b = \frac{P}{k \cdot U_r \cdot \cos\phi}$$

where:

- P is the active power [W];
- k is a coefficient which has the value:
  - 1 for single-phase systems or for direct current systems;
  - $\sqrt{3}$  for three-phase systems;
- U<sub>r</sub> is the rated voltage [V] (for three-phase systems it is the line voltage, for single-phase systems it is the phase voltage);
- cosφ is the power factor.

Table 1 allows the load current to be determined for some power values according to the rated voltage. The table has been calculated considering cosφ to be equal to 0.9; for different power factors, the value from Table 1 must be multiplied by the coefficient given in Table 2 corresponding to the actual value of the power factor (cosφ<sub>act</sub>).

**Table 1: Load current for three-phase systems with cosφ = 0.9**

P [kW]	U <sub>r</sub> [V]						
	230	400	415	440	500	600	690
	I <sub>b</sub> [A]						
0.03	0.08	0.05	0.05	0.04	0.04	0.03	0.03
0.04	0.11	0.06	0.06	0.06	0.05	0.04	0.04
0.06	0.17	0.10	0.09	0.09	0.08	0.06	0.06
0.1	0.28	0.16	0.15	0.15	0.13	0.11	0.09
0.2	0.56	0.32	0.31	0.29	0.26	0.21	0.19
0.5	1.39	0.80	0.77	0.73	0.64	0.53	0.46
1	2.79	1.60	1.55	1.46	1.28	1.07	0.93
2	5.58	3.21	3.09	2.92	2.57	2.14	1.86
5	13.95	8.02	7.73	7.29	6.42	5.35	4.65
10	27.89	16.04	15.46	14.58	12.83	10.69	9.30
20	55.78	32.08	30.92	29.16	25.66	21.38	18.59
30	83.67	48.11	46.37	43.74	38.49	32.08	27.89
40	111.57	64.15	61.83	58.32	51.32	42.77	37.19
50	139.46	80.19	77.29	72.90	64.15	53.46	46.49
60	167.35	96.23	92.75	87.48	76.98	64.15	55.78
70	195.24	112.26	108.20	102.06	89.81	74.84	65.08
80	223.13	128.30	123.66	116.64	102.64	85.53	74.38
90	251.02	144.34	139.12	131.22	115.47	96.23	83.67
100	278.91	160.38	154.58	145.80	128.30	106.92	92.97
110	306.80	176.41	170.04	160.38	141.13	117.61	102.27
120	334.70	192.45	185.49	174.95	153.96	128.30	111.57
130	362.59	208.49	200.95	189.53	166.79	138.99	120.86
140	390.48	224.53	216.41	204.11	179.62	149.68	130.16
150	418.37	240.56	231.87	218.69	192.45	160.38	139.46
200	557.83	320.75	309.16	291.59	256.60	213.83	185.94

## Annex B: Calculation of load current I<sub>b</sub>

P [kW]	U <sub>r</sub> [V]						
	230	400	415	440	500	600	690
	I <sub>b</sub> [A]						
250	697.28	400.94	386.45	364.49	320.75	267.29	232.43
300	836.74	481.13	463.74	437.39	384.90	320.75	278.91
350	976.20	561.31	541.02	510.28	449.05	374.21	325.40
400	1115.65	641.50	618.31	583.18	513.20	427.67	371.88
450	1255.11	721.69	695.60	656.08	577.35	481.13	418.37
500	1394.57	801.88	772.89	728.98	641.50	534.58	464.86
550	1534.02	882.06	850.18	801.88	705.65	588.04	511.34
600	1673.48	962.25	927.47	874.77	769.80	641.50	557.83
650	1812.94	1042.44	1004.76	947.67	833.95	694.96	604.31
700	1952.39	1122.63	1082.05	1020.57	898.10	748.42	650.80
750	2091.85	1202.81	1159.34	1093.47	962.25	801.88	697.28
800	2231.31	1283.00	1236.63	1166.36	1026.40	855.33	743.77
850	2370.76	1363.19	1313.92	1239.26	1090.55	908.79	790.25
900	2510.22	1443.38	1391.21	1312.16	1154.70	962.25	836.74
950	2649.68	1523.56	1468.49	1385.06	1218.85	1015.71	883.23
1000	2789.13	1603.75	1545.78	1457.96	1283.00	1069.17	929.71

**Table 2: Correction factors for load current with cosφ other than 0.9**

cosφ <sub>act</sub>	1	0.95	0.9	0.85	0.8	0.75	0.7
k <sub>cosφ</sub>	0.9	0.947	1	1.059	1.125	1.2	1.286

\* For cosφ<sub>act</sub> values not present in the table,  $k_{\cos\phi} = \frac{0.9}{\cos\phi_{act}}$

Table 3 allows the load current to be determined for some power values according to the rated voltage. The table has been calculated considering cosφ to be equal to 1; for different power factors, the value from Table 3 must be multiplied by the coefficient given in Table 4 corresponding to the actual value of the power factor (cosφ<sub>act</sub>).

**Table 3: Load current for single-phase systems with cosφ = 1 or dc systems**

P [kW]	U <sub>r</sub> [V]						
	230	400	415	440	500	600	690
	I <sub>b</sub> [A]						
0.03	0.13	0.08	0.07	0.07	0.06	0.05	0.04
0.04	0.17	0.10	0.10	0.09	0.08	0.07	0.06
0.06	0.26	0.15	0.14	0.14	0.12	0.10	0.09
0.1	0.43	0.25	0.24	0.23	0.20	0.17	0.14
0.2	0.87	0.50	0.48	0.45	0.40	0.33	0.29
0.5	2.17	1.25	1.20	1.14	1.00	0.83	0.72
1	4.35	2.50	2.41	2.27	2.00	1.67	1.45
2	8.70	5.00	4.82	4.55	4.00	3.33	2.90
5	21.74	12.50	12.05	11.36	10.00	8.33	7.25
10	43.48	25.00	24.10	22.73	20.00	16.67	14.49
20	86.96	50.00	48.19	45.45	40.00	33.33	28.99



Annex B: Calculation of load current I<sub>b</sub>

P [kW]	U <sub>r</sub> [V]						
	230	400	415	440	500	600	690
	I <sub>b</sub> [A]						
30	130.43	75.00	72.29	68.18	60.00	50.00	43.48
40	173.91	100.00	96.39	90.91	80.00	66.67	57.97
50	217.39	125.00	120.48	113.64	100.00	83.33	72.46
60	260.87	150.00	144.58	136.36	120.00	100.00	86.96
70	304.35	175.00	168.67	159.09	140.00	116.67	101.45
80	347.83	200.00	192.77	181.82	160.00	133.33	115.94
90	391.30	225.00	216.87	204.55	180.00	150.00	130.43
100	434.78	250.00	240.96	227.27	200.00	166.67	144.93
110	478.26	275.00	265.06	250.00	220.00	183.33	159.42
120	521.74	300.00	289.16	272.73	240.00	200.00	173.91
130	565.22	325.00	313.25	295.45	260.00	216.67	188.41
140	608.70	350.00	337.35	318.18	280.00	233.33	202.90
150	652.17	375.00	361.45	340.91	300.00	250.00	217.39
200	869.57	500.00	481.93	454.55	400.00	333.33	289.86
250	1086.96	625.00	602.41	568.18	500.00	416.67	362.32
300	1304.35	750.00	722.89	681.82	600.00	500.00	434.78
350	1521.74	875.00	843.37	795.45	700.00	583.33	507.25
400	1739.13	1000.00	963.86	909.09	800.00	666.67	579.71
450	1956.52	1125.00	1084.34	1022.73	900.00	750.00	652.17
500	2173.91	1250.00	1204.82	1136.36	1000.00	833.33	724.64
550	2391.30	1375.00	1325.30	1250.00	1100.00	916.67	797.10
600	2608.70	1500.00	1445.78	1363.64	1200.00	1000.00	869.57
650	2826.09	1625.00	1566.27	1477.27	1300.00	1083.33	942.03
700	3043.48	1750.00	1686.75	1590.91	1400.00	1166.67	1014.49
750	3260.87	1875.00	1807.23	1704.55	1500.00	1250.00	1086.96
800	3478.26	2000.00	1927.71	1818.18	1600.00	1333.33	1159.42
850	3695.65	2125.00	2048.19	1931.82	1700.00	1416.67	1231.88
900	3913.04	2250.00	2168.67	2045.45	1800.00	1500.00	1304.35
950	4130.43	2375.00	2289.16	2159.09	1900.00	1583.33	1376.81
1000	4347.83	2500.00	2409.64	2272.73	2000.00	1666.67	1449.28

Table 4: Correction factors for load current with cos φ other than 1

cos φ <sub>act</sub>	1	0.95	0.9	0.85	0.8	0.75	0.7
k <sub>cosφ</sub>	1	1.053	1.111	1.176	1.25	1.333	1.429

$$\text{For cos } \varphi_{\text{act}} \text{ values not present in the table, } k_{\text{cos}\varphi} = \frac{1}{\text{cos } \varphi_{\text{act}}}$$

## Lighting circuits

The current absorbed by the lighting system may be deduced from the lighting equipment catalogue, or approximately calculated using the following formula:

$$I_b = \frac{P_L n_L k_B k_N}{U_{rL} \cos \varphi}$$

where:

- P<sub>L</sub> is the power of the lamp [W];
- n<sub>L</sub> is the number of lamps per phase;
- k<sub>B</sub> is a coefficient which has the value:
  - 1 for lamps which do not need any auxiliary starter;
  - 1.25 for lamps which need auxiliary starters;
- k<sub>N</sub> is a coefficient which has the value:
  - 1 for star-connected lamps;
  - √3 for delta-connected lamps;
- U<sub>rL</sub> is the rated voltage of the lamps;
- cos φ is the power factor of the lamps which has the value:
  - 0.4 for lamps without compensation;
  - 0.9 for lamps with compensation.

Annex B: Calculation of load current I<sub>b</sub>

## Motors

Table 5 gives the approximate values of the load current for some three-phase squirrel-cage motors, 1500 rpm at 50 Hz, according to the rated voltage.

Note: these values are given for information only, and may vary according to the motor manufacturer and depending on the number of poles

Table 5: Motor load current

Motor power		Rated current of the motor at:							
[kW]	PS = hp	220-230 V [A]	240 V [A]	380-400 V [A]	415 V [A]	440 V [A]	500 V [A]	600 V [A]	660-690 V [A]
0.06	1/12	0.38	0.35	0.22	0.20	0.19	0.16	0.12	-
0.09	1/8	0.55	0.50	0.33	0.30	0.28	0.24	0.21	-
0.12	1/6	0.76	0.68	0.42	0.40	0.37	0.33	0.27	-
0.18	1/4	1.1	1	0.64	0.60	0.55	0.46	0.40	-
0.25	1/3	1.4	1.38	0.88	0.85	0.76	0.59	0.56	-
0.37	1/2	2.1	1.93	1.22	1.15	1.06	0.85	0.77	0.7
0.55	3/4	2.7	2.3	1.5	1.40	1.25	1.20	1.02	0.9
0.75	1	3.3	3.1	2	2	1.67	1.48	1.22	1.1
1.1	1.5	4.9	4.1	2.6	2.5	2.26	2.1	1.66	1.5
1.5	2	6.2	5.6	3.5	3.5	3.03	2.6	2.22	2
2.2	3	8.7	7.9	5	5	4.31	3.8	3.16	2.9
2.5	3.4	9.8	8.9	5.7	5.5	4.9	4.3	3.59	3.3
3	4	11.6	10.6	6.6	6.5	5.8	5.1	4.25	3.5
3.7	5	14.2	13	8.2	7.5	7.1	6.2	5.2	4.4
4	5.5	15.3	14	8.5	8.4	7.6	6.5	5.6	4.9
5	6.8	18.9	17.2	10.5	10	9.4	8.1	6.9	6
5.5	7.5	20.6	18.9	11.5	11	10.3	8.9	7.5	6.7
6.5	8.8	23.7	21.8	13.8	12.5	12	10.4	8.7	8.1
7.5	10	27.4	24.8	15.5	14	13.5	11.9	9.9	9
8	11	28.8	26.4	16.7	15.4	14.4	12.7	10.6	9.7
9	12.5	32	29.3	18.3	17	15.8	13.9	11.6	10.6
11	15	39.2	35.3	22	21	19.3	16.7	14.1	13
12.5	17	43.8	40.2	25	23	21.9	19	16.1	15
15	20	52.6	48.2	30	28	26.3	22.5	19.3	17.5
18.5	25	64.9	58.7	37	35	32	28.5	23.5	21
20	27	69.3	63.4	40	37	34.6	30.6	25.4	23
22	30	75.2	68	44	40	37.1	33	27.2	25
25	34	84.4	77.2	50	47	42.1	38	30.9	28
30	40	101	92.7	60	55	50.1	44	37.1	33
37	50	124	114	72	66	61.9	54	45.4	42
40	54	134	123	79	72	67	60	49.1	44
45	60	150	136	85	80	73.9	64.5	54.2	49
51	70	168	154	97	90	83.8	73.7	61.4	56
55	75	181	166	105	96	90.3	79	66.2	60
59	80	194	178	112	105	96.9	85.3	71.1	66
75	100	245	226	140	135	123	106	90.3	82
80	110	260	241	147	138	131	112	96.3	86
90	125	292	268	170	165	146	128	107	98
100	136	325	297	188	182	162	143	119	107
110	150	358	327	205	200	178	156	131	118
129	175	420	384	242	230	209	184	153	135
132	180	425	393	245	242	214	186	157	140
140	190	449	416	260	250	227	200	167	145
147	200	472	432	273	260	236	207	173	152
160	220	502	471	295	280	256	220	188	170
180	245	578	530	333	320	289	254	212	190
184	250	590	541	340	325	295	259	217	200
200	270	626	589	370	340	321	278	235	215
220	300	700	647	408	385	353	310	260	235
250	340	803	736	460	425	401	353	295	268
257	350	826	756	475	450	412	363	302	280
295	400	948	868	546	500	473	416	348	320
315	430	990	927	580	535	505	445	370	337
355	480	1080	1010	636	580	549	483	405	366
400	545	1250	1130	710	650	611	538	450	410
450	610	1410	1270	800	740	688	608	508	460
475	645	1490	1340	850	780	730	645	540	485
500	680	1570	1420	890	830	770	680	565	510
560	760	1750	1580	1000	920	860	760	630	570
600	810	-	-	1080	990	920	810	680	610
670	910	-	-	1200	1100	1030	910	760	680

## Annex C: Harmonics

### What are they?

The harmonics allow to represent any periodic waveform; in fact, according to Fourier's theorem, any periodic function of a period  $T$  may be represented as a summation of:

- a sinusoid with the same period  $T$ ;
- some sinusoids with the same frequency as whole multiples of the fundamental;
- a possible continuous component, if the function has an average value not null in the period.

The harmonic with frequency corresponding to the period of the original waveform is called fundamental and the harmonic with frequency equal to " $n$ " times that of the fundamental is called harmonic component of order " $n$ ".

A perfectly sinusoidal waveform complying with Fourier's theorem does not present harmonic components of order different from the fundamental one. Therefore, it is understandable how there are no harmonics in an electrical system when the waveforms of current and voltage are sinusoidal. On the contrary, the presence of harmonics in an electrical system is an index of the distortion of the voltage or current waveform and this implies such a distribution of the electric power that malfunctioning of equipment and protective devices can be caused.

To summarize: the harmonics are nothing less than the components of a distorted waveform and their use allows us to analyse any periodic nonsinusoidal waveform through different sinusoidal waveform components.

Figure 1 below shows a graphical representation of this concept.

Figure 1

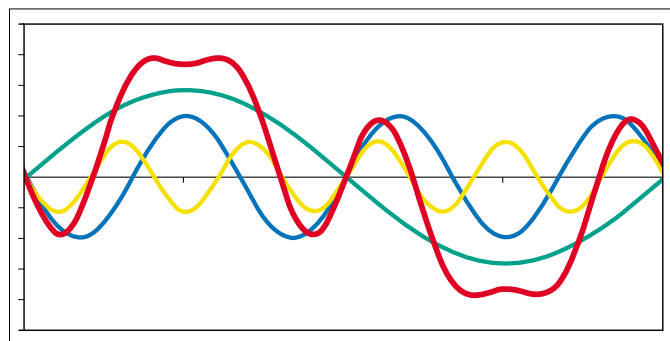

Caption:

- nonsinusoidal waveform
- first harmonic (fundamental)
- third harmonic
- fifth harmonic

## Annex C: Harmonics

### How harmonics are generated?

Harmonics are generated by nonlinear loads. When we apply a sinusoidal voltage to a load of this type, we shall obtain a current with non-sinusoidal waveform. The diagram of Figure 2 illustrates an example of nonsinusoidal current waveform due to a nonlinear load:

Figure 2

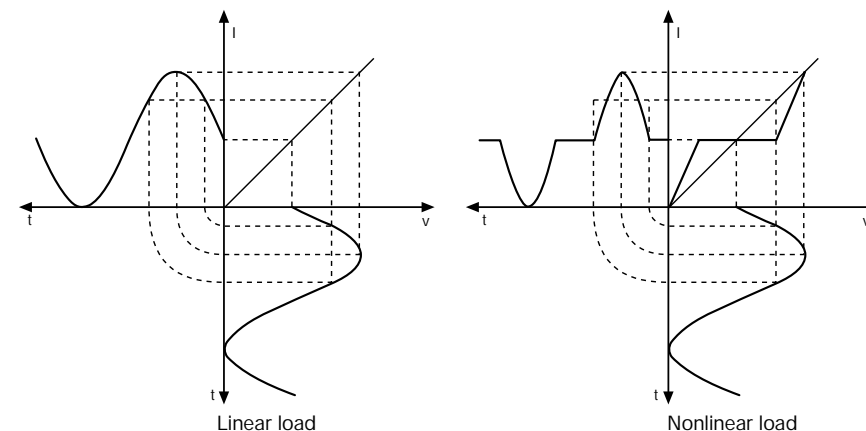

As already said, this nonsinusoidal waveform can be deconstructed into harmonics. If the network impedances are very low, the voltage distortion resulting from a harmonic current is low too and rarely it is above the pollution level already present in the network. As a consequence, the voltage can remain practically sinusoidal also in the presence of current harmonics.

To function properly, many electronic devices need a definite current waveform and thus they have to 'cut' the sinusoidal waveform so as to change its rms value or to get a direct current from an alternate value; in these cases the current on the line has a nonsinusoidal curve.

The main equipment generating harmonics are:

- personal computer
- fluorescent lamps
- static converters
- continuity groups
- variable speed drives
- welders

In general, waveform distortion is due to the presence, inside of these equipment, of bridge rectifiers, whose semiconductor devices carry the current only for a fraction of the whole period, thus originating discontinuous curves with the consequent introduction of numerous harmonics.



## Annex C: Harmonics

Also transformers can be cause of harmonic pollution; in fact, by applying a perfectly sinusoidal voltage to a transformer, it results into a sinusoidal magnetizing flux, but, due to the phenomenon of the magnetic saturation of iron, the magnetizing current shall not be sinusoidal. Figure 3 shows a graphic representation of this phenomenon:

Figure 3

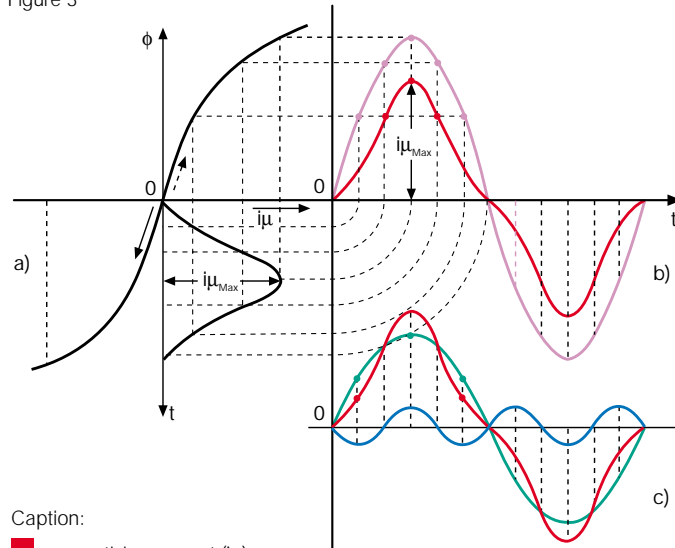

Caption:

- magnetizing current ( $i_{\mu}$ )
- first harmonic current (fundamental)
- third harmonic current
- flux variable in time:  $\phi = \phi_{Max} \sin \omega t$

The resultant waveform of the magnetizing current contains numerous harmonics, the greatest of which is the third one. However, it should be noted that the magnetizing current is generally a little percentage of the rated current of the transformer and the distortion effect becomes more and more negligible the most loaded the transformer results to be.

### Effects

The main problems caused by harmonic currents are:

- 1) overloading of neutrals
- 2) increase of losses in the transformers
- 3) increase of skin effect

The main effects of the harmonics voltages are:

- 4) voltage distortion
- 5) disturbances in the torque of induction motors

## Annex C: Harmonics

### 1) Overloading of neutrals

In a three phase symmetric and balanced system with neutral, the waveforms between the phases are shifted by a  $120^\circ$  phase angle so that, when the phases are equally loaded, the current in the neutral is zero. The presence of unbalanced loads (phase-to-phase, phase-to-neutral etc.) allows the flowing of an unbalanced current in the neutral.

Figure 4

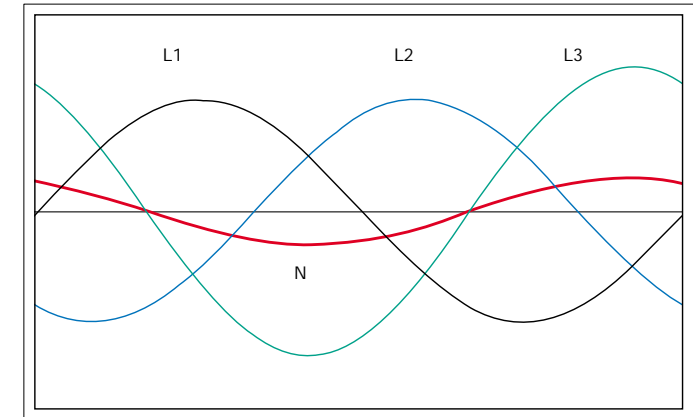

Figure 4 shows an unbalanced system of currents (phase 3 with a load 30% higher than the other two phases), and the current resultant in the neutral is highlighted in red. Under these circumstances, the Standards allow the neutral conductor to be dimensioned with a cross section smaller than the phase conductors. In the presence of distortion loads it is necessary to evaluate correctly the effects of harmonics.

In fact, although the currents at fundamental frequency in the three phases cancel each other out, the components of the third harmonic, having a period equal to a third of the fundamental, that is equal to the phase shift between the phases (see Figure 5), are reciprocally in phase and consequently they sum in the neutral conductor adding themselves to the normal unbalance currents.

The same is true also for the harmonics multiple of three (even and odd, although actually the odd ones are more common).

## Annex C: Harmonics

Figure 5

Phase 1:  
fundamental harmonic and 3<sup>rd</sup> harmonic

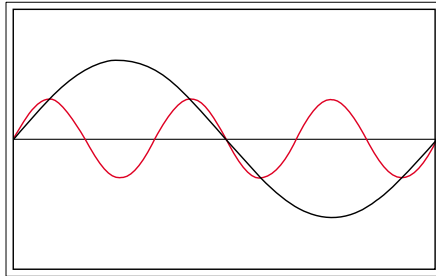

Phase 2:  
fundamental harmonic and 3<sup>rd</sup> harmonic

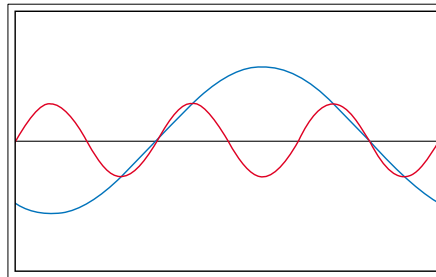

Phase 3:  
fundamental harmonic and 3<sup>rd</sup> harmonic

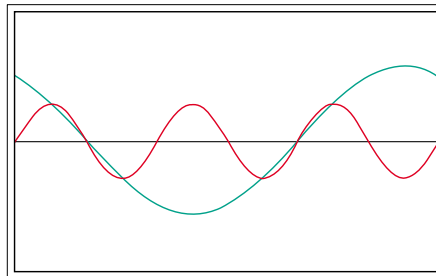

Resultant of the currents of the three phases

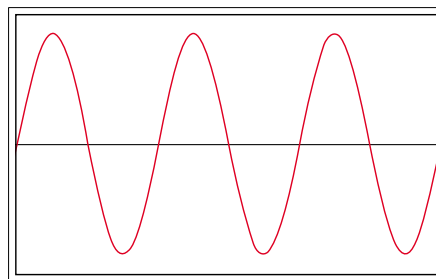

## Annex C: Harmonics

### 2) Increase of losses in the transformers

The effects of harmonics inside the transformers involve mainly three aspects:

- a) increase of iron losses (or no-load losses)
- b) increase of copper losses
- c) presence of harmonics circulating in the windings

a) The iron losses are due to the hysteresis phenomenon and to the losses caused by eddy currents; the losses due to hysteresis are proportional to the frequency, whereas the losses due to eddy currents depend on the square of the frequency.

b) The copper losses correspond to the power dissipated by Joule effect in the transformer windings. As the frequency rises (starting from 350 Hz) the current tends to thicken on the surface of the conductors (skin effect); under these circumstances, the conductors offer a smaller cross section to the current flow, since the losses by Joule effect increase.

These two first aspects affect the overheating which sometimes causes a derating of the transformer.

c) The third aspect is relevant to the effects of the triple-N harmonics (homopolar harmonics) on the transformer windings. In case of delta windings, the harmonics flow through the windings and do not propagate upstream towards the network since they are all in phase; the delta windings therefore represent a barrier for triple-N harmonics, but it is necessary to pay particular attention to this type of harmonic components for a correct dimensioning of the transformer.

### 3) Increase of skin effect

When the frequency rises, the current tends to flow on the outer surface of a conductor. This phenomenon is known as skin effect and is more pronounced at high frequencies. At 50 Hz power supply frequency, skin effect is negligible, but above 350 Hz, which corresponds to the 7th harmonic, the cross section for the current flow reduces, thus increasing the resistance and causing additional losses and heating.

In the presence of high-order harmonics, it is necessary to take skin effect into account, because it affects the life of cables. In order to overcome this problem, it is possible to use multiple conductor cables or busbar systems formed by more elementary isolated conductors.

### 4) Voltage distortion

The distorted load current drawn by the nonlinear load causes a distorted voltage drop in the cable impedance. The resultant distorted voltage waveform is applied to all other loads connected to the same circuit, causing harmonic currents to flow in them, even if they are linear loads.

The solution consists in separating the circuits which supply harmonic generating loads from those supplying loads sensitive to harmonics.

### 5) Disturbances in the torque of induction motors

Harmonic voltage distortion causes increased eddy current losses in the motors, in the same way as seen for transformers. The additional losses are due to the generation of harmonic fields in the stator, each of which is trying to rotate the motor at a different speed, both forwards (1<sup>st</sup>, 4<sup>th</sup>, 7<sup>th</sup>, ...) as well as backwards (2<sup>nd</sup>, 5<sup>th</sup>, 8<sup>th</sup>, ...). High frequency currents induced in the rotor further increase losses.

## Annex C: Harmonics

### Main formulas

The definitions of the main quantities typically used in a harmonic analysis are given hereunder.

#### Frequency spectrum

The frequency spectrum is the classic representation of the harmonic content of a waveform and consists of a histogram reporting the value of each harmonic as a percentage of the fundamental component. For example, for the following waveform:

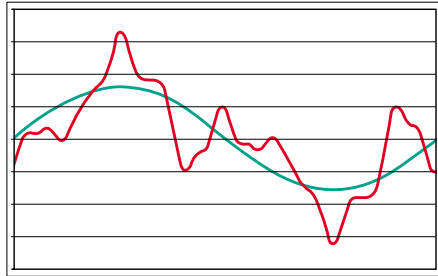

the frequency spectrum is:

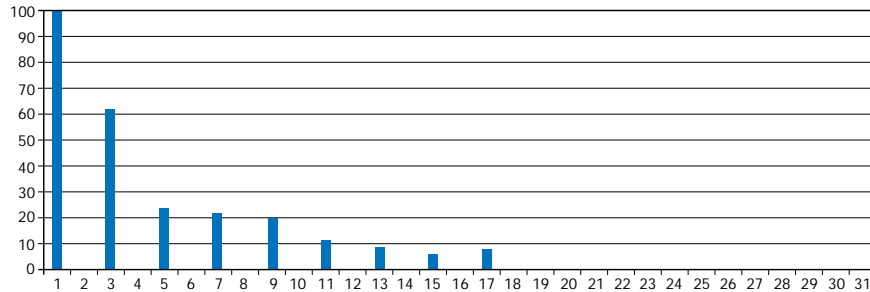

The frequency spectrum provides the size of the existing harmonic components.

#### Peak factor

The peak factor is defined as the ratio between the peak value and the rms value of the waveform:

$$k = \frac{I_p}{I_{rms}}$$

in case of perfectly sinusoidal waveforms, it is worth  $\sqrt{2}$ , but in the presence of harmonics it can reach higher values.

High peak factors may cause the unwanted tripping of the protection devices.

#### Rms value

The rms value of a periodical waveform  $e(t)$  is defined as:

$$E_{rms} = \sqrt{\frac{1}{T} \int_0^T e^2(t) dt}$$

where T is the period.

## Annex C: Harmonics

If the rms values of the harmonic components are known, the total rms value can be easily calculated by the following formula:

$$E_{rms} = \sqrt{\sum_{n=1}^{\infty} E_n^2}$$

#### Total harmonic distortion THD

The total harmonic distortion is defined as:

$$THD_i = \frac{\sqrt{\sum_{n=2}^{\infty} I_n^2}}{I_1} \quad \text{THD in current}$$

$$THD_u = \frac{\sqrt{\sum_{n=2}^{\infty} U_n^2}}{U_1} \quad \text{THD in voltage}$$

The harmonic distortion ratio is a very important parameter, which gives information about the harmonic content of the voltage and current waveforms and about the necessary measures to be taken should these values be high. For  $THD_i < 10\%$  and  $THD_u < 5\%$ , the harmonic content is considered negligible and such as not to require any provisions.

#### Standard references for circuit-breakers

##### IEC 60947 Low-voltage switchgear and controlgear

Annex F of the Standard IEC 60947-2 (third edition 2003) gives information about the tests to check the immunity of the overcurrent releases against harmonics.

In particular, it describes the waveform of the test current, at which, in correspondence with determinate values of injected current, the release shall have a behaviour complying with the prescriptions of this Standard.

Hereunder, the characteristics of the waveform of the test current are reported, which shall be formed, in alternative, as follows:

1) by the fundamental component and by a 3rd harmonic variable between 72% and 88% of the fundamental, with peak factor equal to 2 or by a 5th harmonic variable between 45% and 55% of the fundamental, with peak factor equal to 1.9

or

2) by the fundamental component and by a 3rd harmonic higher than 60% of the fundamental, by a 5th harmonic higher than 14% of the fundamental and by a 7th harmonic higher than 7% of the fundamental. This test current shall have a peak factor  $\geq 2.1$  and shall flow for a given time  $\leq 42\%$  of the period for each half period.

## Annex D: Calculation of the coefficient k for the cables ( $k^2S^2$ )

By using the formula (1), it is possible to determine the conductor minimum section S, in the hypothesis that the generic conductor is submitted to an adiabatic heating from a known initial temperature up to a specific final temperature (applicable if the fault is removed in less than 5 s):

$$S = \frac{\sqrt{I^2 t}}{k} \quad (1)$$

where:

- S is the cross section [mm<sup>2</sup>];
- I is the value (r.m.s) of prospective fault current for a fault of negligible impedance, which can flow through the protective device [A];
- t is the operating time of the protective device for automatic disconnection [s];
- k can be evaluated using the tables 2+7 or calculated according to the formula (2):

$$k = \sqrt{\frac{Q_c (B+20)}{\rho_{20}} \ln \left( 1 + \frac{\theta_f - \theta_i}{B + \theta_i} \right)} \quad (2)$$

where:

- $Q_c$  is the volumetric heat capacity of conductor material [J/°Cmm<sup>3</sup>] at 20 °C;
- B is the reciprocal of temperature coefficient of resistivity at 0 °C for the conductor [°C];
- $\rho_{20}$  is the electrical resistivity of conductor material at 20 °C [Ωmm];
- $\theta_i$  initial temperature of conductor [°C];
- $\theta_f$  final temperature of conductor [°C].

Table 1 shows the values of the parameters described above.

**Table 1: Value of parameters for different materials**

Material	B [°C]	$Q_c$ [J/°Cmm <sup>3</sup> ]	$\rho_{20}$ [Ωmm]	$\sqrt{\frac{Q_c (B+20)}{\rho_{20}}}$
Copper	234.5	$3.45 \cdot 10^{-3}$	$17.241 \cdot 10^{-6}$	226
Aluminium	228	$2.5 \cdot 10^{-3}$	$28.264 \cdot 10^{-6}$	148
Lead	230	$1.45 \cdot 10^{-3}$	$214 \cdot 10^{-6}$	41
Steel	202	$3.8 \cdot 10^{-3}$	$138 \cdot 10^{-6}$	78

## Annex D: Calculation of the coefficient k for the cables ( $k^2S^2$ )

**Table 2: Values of k for phase conductor**

	Conductor insulation					Mineral Bare
	PVC ≤ 300 mm <sup>2</sup>	PVC ≤ 300 mm <sup>2</sup>	EPR XLPE	Rubber 60 °C	PVC	
Initial temperature °C	70	70	90	60	70	105
Final temperature °C	160	140	250	200	160	250
Material of conductor:						
<i>copper</i>	115	103	143	141	115	135/115 <sup>a</sup>
<i>aluminium</i>	76	68	94	93	-	-
<i>tin-soldered joints in copper conductors</i>	115	-	-	-	-	-

<sup>a</sup> This value shall be used for bare cables exposed to touch.

**Table 3: Values of k for insulated protective conductors not incorporated in cables and not bunched with other cables**

Conductor insulation	Temperature °C <sup>b</sup>		Material of conductor		
	Initial	Final	Copper	Aluminium Value for k	Steel
70 °C PVC	30	160/140 <sup>a</sup>	143/133 <sup>a</sup>	95/88 <sup>a</sup>	52/49 <sup>a</sup>
90 °C PVC	30	160/140 <sup>a</sup>	143/133 <sup>a</sup>	95/88 <sup>a</sup>	52/49 <sup>a</sup>
90 °C thermosetting	30	250	176	116	64
60 °C rubber	30	200	159	105	58
85 °C rubber	30	220	166	110	60
Silicone rubber	30	350	201	133	73

<sup>a</sup> The lower value applies to PVC insulated conductors of cross section greater than 300 mm<sup>2</sup>.

<sup>b</sup> Temperature limits for various types of insulation are given in IEC 60724.

## Annex D: Calculation of the coefficient k for the cables ( $k^2S^2$ )

Table 4: Values of k for bare protective conductors in contact with cable covering but not bunched with other cables

Cable covering	Temperature °C <sup>a</sup>		Material of conductor		
	Initial	Final	Copper	Aluminium Value for k	Steel
PVC	30	200	159	105	58
Polyethylene	30	150	138	91	50
CSP	30	220	166	110	60

<sup>a</sup> Temperature limits for various types of insulation are given in IEC 60724.

Table 5: Values of k for protective conductors as a core incorporated in a cable or bunched with other cables or insulated conductors

Conductor insulation	Temperature °C <sup>b</sup>		Material of conductor		
	Initial	Final	Copper	Aluminium Value for k	Steel
70 °C PVC	70	160/140 <sup>a</sup>	115/103 <sup>a</sup>	76/68 <sup>a</sup>	42/37 <sup>a</sup>
90 °C PVC	90	160/140 <sup>a</sup>	100/86 <sup>a</sup>	66/57 <sup>a</sup>	36/31 <sup>a</sup>
90 °C thermosetting	90	250	143	94	52
60 °C rubber	60	200	141	93	51
85 °C rubber	85	220	134	89	48
Silicone rubber	180	350	132	87	47

<sup>a</sup> The lower value applies to PVC insulated conductors of cross section greater than 300 mm<sup>2</sup>.

<sup>b</sup> Temperature limits for various types of insulation are given in IEC 60724.

## Annex D: Calculation of the coefficient k for the cables ( $k^2S^2$ )

Table 6: Values of k for protective conductors as a metallic layer of a cable e.g. armour, metallic sheath, concentric conductor, etc.

Conductor insulation	Temperature °C		Material of conductor			
	Initial	Final	Copper	Aluminium Value for k	Lead	Steel
70 °C PVC	60	200	141	93	26	51
90 °C PVC	80	200	128	85	23	46
90 °C thermosetting	80	200	128	85	23	46
60 °C rubber	55	200	144	95	26	52
85 °C rubber	75	220	140	93	26	51
Mineral PVC covered <sup>a</sup>	70	200	135	-	-	-
Mineral bare sheath	105	250	135	-	-	-

<sup>a</sup> This value shall also be used for bare conductors exposed to touch or in contact with combustible material.

Table 7: Value of k for bare conductors where there is no risk of damage to any neighbouring material by the temperature indicated

Conductor insulation	Initial temperature °C	Material of conductor					
		Copper		Aluminium		Steel	
		Maximum temperature °C	k value	Maximum temperature °C	k value	Maximum temperature °C	k value
Visible and in restricted area	30	228	500	125	300	82	500
Normal conditions	30	159	200	105	200	58	200
Fire risk	30	138	150	91	150	50	150

## Annex E: Main physical quantities and electrotechnical formulas

### The International System of Units (SI)

#### SI Base Units

Quantity	Symbol	Unit name
Length	m	metre
Mass	kg	kilogram
Time	s	Second
Electric Current	A	ampere
Thermodynamic Temperature	K	kelvin
Amount of Substance	mol	mole
Luminous Intensity	cd	candela

#### Metric Prefixes for Multiples and Sub-multiples of Units

Decimal power	Prefix	Symbol	Decimal power	Prefix	Symbol
10 <sup>24</sup>	yotta	Y	10 <sup>-1</sup>	deci	d
10 <sup>21</sup>	zetta	Z	10 <sup>-2</sup>	centi	c
10 <sup>18</sup>	exa	E	10 <sup>-3</sup>	milli	m
10 <sup>15</sup>	peta	P	10 <sup>-6</sup>	mikro	μ
10 <sup>12</sup>	tera	T	10 <sup>-9</sup>	nano	n
10 <sup>9</sup>	giga	G	10 <sup>-12</sup>	pico	p
10 <sup>6</sup>	mega	M	10 <sup>-15</sup>	femto	f
10 <sup>3</sup>	kilo	k	10 <sup>-18</sup>	atto	a
10 <sup>2</sup>	etto	h	10 <sup>-21</sup>	zepto	z
10	deca	da	10 <sup>-24</sup>	yocto	y

## Annex E: Main physical quantities and electrotechnical formulas

### Main quantities and SI units

Quantity Symbol	Name	SI unit Symbol	Name	Other units Symbol	Name	Conversion
<b>Length, area, volume</b>						
l	length	m	metre	in	inch	1 in = 25.4 mm
				ft	foot	1 ft = 30.48 cm
				fathom	fathom	1 fathom = 6 ft = 1.8288 m
				mile	mile	1 mile = 1609.344 m
				sm	sea mile	1 sm = 1852 m
A	area	m <sup>2</sup>	square metre	yd	yard	1 yd = 91.44 cm
				a	are	1 a = 10 <sup>2</sup> m <sup>2</sup>
V	volume	m <sup>3</sup>	cubic metre	ha	hectare	1 ha = 10 <sup>4</sup> m <sup>2</sup>
				l	litre	1 l = 1 dm <sup>3</sup> = 10 <sup>-3</sup> m <sup>3</sup>
				UK pt	pint	1 UK pt = 0.5683 dm <sup>3</sup>
				UK gal	gallon	1 UK gal = 4.5461 dm <sup>3</sup>
				US gal	gallon	1 US gal = 3.7855 dm <sup>3</sup>
<b>Angles</b>						
α, β, γ	plane angle	rad	radian	°	degrees	1° = $\frac{\pi}{180}$ · rad
Ω	solid angle	sr	steradian			
<b>Mass</b>						
m	mass, weight	kg	kilogram	lb	pound	1 lb = 0.45359 kg
ρ	density	kg/m <sup>3</sup>	kilogram			
v	specific volume	m <sup>3</sup> /kg	cubic metre for kilogram			
M	moment of inertia	kg·m <sup>2</sup>	kilogram for square metre			
<b>Time</b>						
t	duration	s	second			
f	frequency	Hz	Hertz			1 Hz = 1/s
ω	angular frequency	1/s	reciprocal second			ω = 2πf
v	speed	m/s	metre per second	km/h	kilometre per hour	1 km/h = 0.2777 m/s
				mile/h	mile per hour	1 mile/h = 0.4470 m/s
				knot	kn	1 kn = 0.5144 m/s
g	acceleration	m/s <sup>2</sup>	metre per second squared			
<b>Force, energy, power</b>						
F	force	N	newton	kgf		1 N = 1 kg·m/s <sup>2</sup> 1 kgf = 9.80665 N
p	pressure/stress	Pa	pascal	bar	bar	1 Pa = 1 N/m <sup>2</sup> 1 bar = 10 <sup>5</sup> Pa
W	energy, work	J	joule			1 J = 1 W·s = 1 N·m
P	power	W	watt	Hp	horsepower	1 Hp = 745.7 W
<b>Temperature and heat</b>						
T	temperature	K	kelvin	°C	Celsius	T[K] = 273.15 + T [°C]
Q	quantity of heat	J	joule	°F	Fahrenheit	T[K] = 273.15 + (5/9)·(T [°F]-32)
S	entropy	J/K	joule per kelvin			
<b>Photometric quantities</b>						
I	luminous intensity	cd	candela			
L	luminance	cd/m <sup>2</sup>	candela per square metre			
Φ	luminous flux	lm	lumen			1 lm = 1 cd·sr
E	illuminance	lux	lux			1 lux = 1 lm/m <sup>2</sup>

## Annex E: Main physical quantities and electrotechnical formulas

### Main electrical and magnetic quantities and SI units

Quantity Symbol	Name	SI unit Symbol	Name	Other units Symbol	Name	Conversion
I	current	A	ampere			
V	voltage	V	volt			
R	resistance	$\Omega$	ohm			
G	conductance	S	siemens			$G = 1/R$
X	reactance	$\Omega$	ohm			$X_L = \omega L$ $X_C = -1/\omega C$
B	susceptance	S	siemens			$B_L = -1/\omega L$ $B_C = \omega C$
Z	impedance	$\Omega$	ohm			
Y	admittance	S	siemens			
P	active power	W	watt			
Q	reactive power	var	reactive volt ampere			
S	apparent power	VA	volt ampere			
Q	electric charge	C	coulomb	Ah	ampere/hour	$1 C = 1 A \cdot s$ $1 Ah = 3600 A \cdot s$
E	electric field strength	V/m	volt per metre			
C	electric capacitance	F	farad			$1 F = 1 C/V$
H	magnetic field	A/m	ampere per metre			
B	magnetic induction	T	tesla	G	gauss	$1 T = 1 V \cdot s/m^2$ $1 G = 10^{-4} T$
L	inductance	H	henry			$1 H = 1 \Omega \cdot s$

### Resistivity values, conductivity and temperature coefficient at 20 °C of the main electrical materials

conductor	conductivity resistivity $\rho_{20}$ [mm <sup>2</sup> $\Omega$ /m]	$\chi_{20}=1/\rho_{20}$ [m/mm <sup>2</sup> $\Omega$ ]	temperature coefficient $\alpha_{20}$ [K <sup>-1</sup> ]
Aluminium	0.0287	34.84	$3.8 \cdot 10^{-3}$
Brass, CuZn 40	$\leq 0.067$	$\geq 15$	$2 \cdot 10^{-3}$
Constantan	0.50	2	$-3 \cdot 10^{-4}$
Copper	0.0175	57.14	$3.95 \cdot 10^{-3}$
Gold	0.023	43.5	$3.8 \cdot 10^{-3}$
Iron wire	0.1 to 0,15	10 to 6.7	$4.5 \cdot 10^{-3}$
Lead	0.208	4.81	$3.9 \cdot 10^{-3}$
Magnesium	0.043	23.26	$4.1 \cdot 10^{-3}$
Manganin	0.43	2.33	$4 \cdot 10^{-6}$
Mercury	0.941	1.06	$9.2 \cdot 10^{-4}$
Ni Cr 8020	1	1	$2.5 \cdot 10^{-4}$
Nickeline	0.43	2.33	$2.3 \cdot 10^{-4}$
Silver	0.016	62.5	$3.8 \cdot 10^{-3}$
Zinc	0.06	16.7	$4.2 \cdot 10^{-3}$

## Annex E: Main physical quantities and electrotechnical formulas

### Main electrotechnical formulas

#### Impedance

resistance of a conductor at temperature $\vartheta$	$R_{\vartheta} = \rho_{\vartheta} \cdot \frac{\ell}{S}$
conductance of a conductor at temperature $\vartheta$	$G_{\vartheta} = \frac{1}{R_{\vartheta}} = \chi_{\vartheta} \cdot \frac{S}{\ell}$
resistivity of a conductor at temperature $\vartheta$	$\rho_{\vartheta} = \rho_{20} [1 + \alpha_{20} (\vartheta - 20)]$
capacitive reactance	$X_C = \frac{-1}{\omega \cdot C} = - \frac{1}{2 \cdot \pi \cdot f \cdot C}$
inductive reactance	$X_L = \omega \cdot L = 2 \cdot \pi \cdot f \cdot L$
impedance	$Z = R + jX$
module impedance	$Z = \sqrt{R^2 + X^2}$
phase impedance	$\varphi = \arctan \frac{R}{X}$
conductance	$G = \frac{1}{R}$
capacitive susceptance	$B_C = \frac{-1}{X_C} = \omega \cdot C = 2 \cdot \pi \cdot f \cdot C$
inductive susceptance	$B_L = \frac{-1}{X_L} = - \frac{1}{\omega \cdot L} = - \frac{1}{2 \cdot \pi \cdot f \cdot L}$
admittance	$Y = G - jB$
module admittance	$Y = \sqrt{G^2 + B^2}$
phase admittance	$\varphi = \arctan \frac{B}{G}$

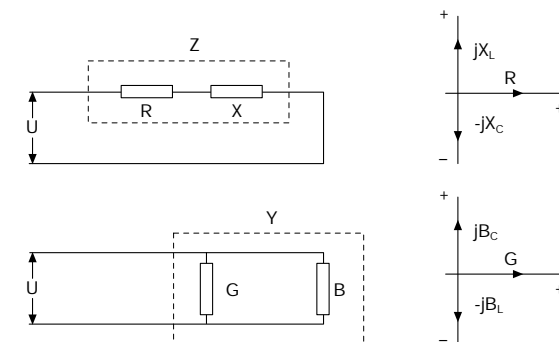

## Annex E: Main physical quantities and electrotechnical formulas

Impedances in series

$$Z = Z_1 + Z_2 + Z_3 + \dots$$

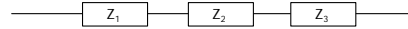

Admittances in series

$$Y = \frac{1}{\frac{1}{Y_1} + \frac{1}{Y_2} + \frac{1}{Y_3} + \dots}$$

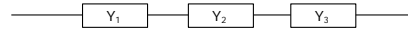

Impedances in parallel

$$Z = \frac{1}{\frac{1}{Z_1} + \frac{1}{Z_2} + \frac{1}{Z_3} + \dots}$$

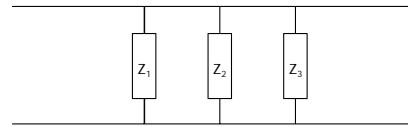

Admittances in parallel

$$Y = Y_1 + Y_2 + Y_3 + \dots$$

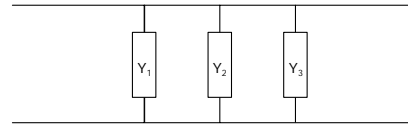

Delta-star and star-delta transformations

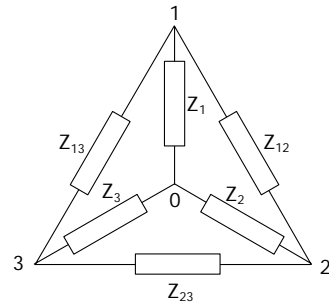

$Y \rightarrow \Delta$	$\Delta \rightarrow Y$
$Z_{12} = Z_1 + Z_2 + \frac{Z_1 \cdot Z_2}{Z_3}$	$Z_1 = \frac{Z_{12} \cdot Z_{13}}{Z_{12} + Z_{13} + Z_{23}}$
$Z_{23} = Z_2 + Z_3 + \frac{Z_2 \cdot Z_3}{Z_1}$	$Z_2 = \frac{Z_{12} \cdot Z_{23}}{Z_{12} + Z_{13} + Z_{23}}$
$Z_{13} = Z_3 + Z_1 + \frac{Z_3 \cdot Z_1}{Z_2}$	$Z_3 = \frac{Z_{23} \cdot Z_{13}}{Z_{12} + Z_{13} + Z_{23}}$

## Annex E: Main physical quantities and electrotechnical formulas

### Transformers

Two-winding transformer

rated current	$I_r = \frac{S_r}{\sqrt{3} \cdot U_r}$
short-circuit power	$S_k = \frac{S_r}{u_k\%} \cdot 100$
short-circuit current	$I_k = \frac{S_k}{\sqrt{3} \cdot U_r} = \frac{I_r}{u_k\%} \cdot 100$
longitudinal impedance	$Z_T = \frac{u_k\%}{100} \cdot \frac{U_r^2}{S_r} = \frac{u_k\%}{100} \cdot \frac{S_r}{3 \cdot I_r^2}$
longitudinal resistance	$R_T = \frac{p_k\%}{100} \cdot \frac{U_r^2}{S_r} = \frac{p_k\%}{100} \cdot \frac{S_r}{3 \cdot I_r^2}$
longitudinal reactance	$X_T = \sqrt{Z_T^2 - R_T^2}$

Three-winding transformer

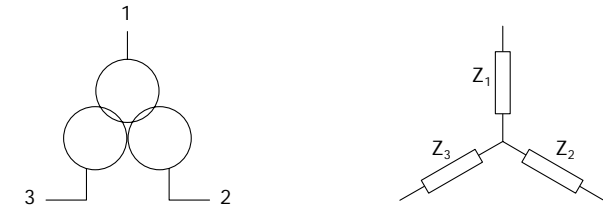

$$Z_{12} = \frac{u_{12}}{100} \cdot \frac{U_r^2}{S_{r12}}$$

$$Z_1 = \frac{1}{2} (Z_{12} + Z_{13} - Z_{23})$$

$$Z_{13} = \frac{u_{13}}{100} \cdot \frac{U_r^2}{S_{r13}}$$

$$Z_2 = \frac{1}{2} (Z_{12} + Z_{23} - Z_{13})$$

$$Z_{23} = \frac{u_{23}}{100} \cdot \frac{U_r^2}{S_{r23}}$$

$$Z_3 = \frac{1}{2} (Z_{13} + Z_{23} - Z_{12})$$



## Annex E: Main physical quantities and electrotechnical formulas

### Voltage drop and power

	single-phase	three-phase	direct current
voltage drop	$\Delta U = 2 \cdot I \cdot \ell \cdot (r \cos\varphi + x \sin\varphi)$	$\Delta U = \sqrt{3} \cdot I \cdot \ell \cdot (r \cos\varphi + x \sin\varphi)$	$\Delta U = 2 \cdot I \cdot \ell \cdot r$
percentage voltage drop	$\Delta u = \frac{\Delta U}{U_r} \cdot 100$	$\Delta u = \frac{\Delta U}{U_r} \cdot 100$	$\Delta u = \frac{\Delta U}{U_r} \cdot 100$
active power	$P = U \cdot I \cdot \cos\varphi$	$P = \sqrt{3} \cdot U \cdot I \cdot \cos\varphi$	$P = U \cdot I$
reactive power	$Q = U \cdot I \cdot \sin\varphi$	$Q = \sqrt{3} \cdot U \cdot I \cdot \sin\varphi$	-
apparent power	$S = U \cdot I = \sqrt{P^2 + Q^2}$	$S = \sqrt{3} \cdot U \cdot I = \sqrt{P^2 + Q^2}$	-
power factor	$\cos\varphi = \frac{P}{S}$	$\cos\varphi = \frac{P}{S}$	-
power loss	$\Delta P = 2 \cdot \ell \cdot r \cdot I^2$	$\Delta P = 3 \cdot \ell \cdot r \cdot I^2$	$\Delta P = 2 \cdot \ell \cdot r \cdot I^2$

### Caption

- $\rho_{20}$  resistivity at 20 °C
- $\ell$  total length of conductor
- $S$  cross section of conductor
- $\alpha_{20}$  temperature coefficient of conductor at 20 °C
- $\theta$  temperature of conductor
- $\rho\theta$  resistivity against the conductor temperature
- $\omega$  angular frequency
- $f$  frequency
- $r$  resistance of conductor per length unit
- $x$  reactance of conductor per length unit
- $u_k\%$  short-circuit percentage voltage of the transformer
- $S_r$  rated apparent power of the transformer
- $U_r$  rated voltage of the transformer
- $p_k\%$  percentage impedance losses of the transformer under short-circuit conditions



Due to possible developments of standards as well as of materials, the characteristics and dimensions specified in this document may only be considered binding after confirmation by ABB SACE.

---

**ABB SACE S.p.A.**

An ABB Group Company

*L.V. Breakers*

Via Baioni, 35

24123 Bergamo - Italy

Tel.: +39 035.395.111 - Telefax: +39 035.395.306-433

***<http://www.abb.com>***